



BSR SampleRail

**BSR
User Manual**

Version 002



The information in this manual may be altered without notice.

BRUKER BIOSPIN accepts no responsibility for actions taken as a result of use of this manual. BRUKER BIOSPIN accepts no liability for any mistakes contained in the manual, leading to coincidental damage, whether during installation or operation of the instrument. Unauthorized reproduction of manual contents, without written permission from the publishers, or translation into another language, either in full or in part, is forbidden.

This manual was written by

Klaus Ruf

© June 30, 2005: Bruker Biospin GmbH

Rheinstetten, Germany

P/N: Z31571
DWG-Nr.: 1283002

DECLARATION OF CONFORMITY

The under mentioned product(s)
BSR SampleRail
P/N H9617
BSR Sample Rail VAC Left
P/N H10175
BSR Sample Rail VAC Right
P/N H10192

conform(s) to the main requirements set by the commission for the Harmonization of Regulations of the EU Member States with regards to electromagnetic compatibility regulations (EMI: 89/336/ECC), safety regulations (Low Voltage Electrical Equipment: 72/23/ECC), and machinery directives (98/37/ECC).

For the assessment the following norms were applied:

EMI: Emission: EN 61326:1997/A1:1998 / Class A;
Immunity: EN 61326:1997/A1:1998 / EMC controlled area

Safety: IEC 61010-1. 2ed. 2001-02

Machinery Directives: DIN EN ISO 12100 - 1 & 2: 2004

Test report, NEMKO: CB Test Certificate NO30790
Documentation: - Docu Standard: BSR SampleRail



Manufacturer's Name: BRUKER BIOSPIN GMBH
Manufacturer's Address: Silberstreifen 4,
D-76287 Rheinstetten,
Germany

Declaration approved by:

Dr. Tonio Gianotti

Head of Development

Rheinstetten March 9, 2005

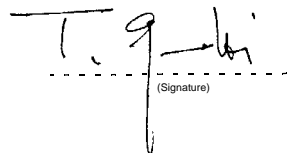
(Signature)

Contents

	Contents	5
1	Introduction	9
1.1	Bruker SampleRail	9
1.2	About This Manual	10
1.3	Trademarks	10
1.4	Warnings and Notes	10
1.5	Contact for Additional Technical Assistance	11
2	Safety Considerations	13
2.1	Disclaimer	13
2.2	Important Safety Considerations	13
2.3	Correct Usage of SampleRail	14
	Personnel Safety	14
	Technically Qualified Personnel Only	14
	Hazards from Samples, Breakage of Glass... and Other Substances	15
	Availability of Information	15
	Before the First Start	15
	Activities Before Each Start	16
	Normal Operation	16
	Maintenance	16
	Cleaning	17
	Replacement Parts	17
	Installation, Relocation and Disposal of the Device	18
2.4	Customer Responsibilities	18
2.5	Potentially Hazardous Areas	19
	Moving parts	19
	Electrical parts	20
3	System Description	21
3.1	The SampleRail System	21
	Horizontal and Vertical Units	21
	The SampleRail/Robot Transfer Unit	21
	The Transfer Unit Vertical/Horizontal	22
	The SampleRail/Magnet Transfer Unit	22
	Sample Trolley	22
	Fixing and Mounting Parts	22
	SampleRail Control and Pneumatic Unit	22
3.2	Bruker SampleRail VAC	24
3.3	Where to Find the Type Label	25

4	<i>Installation Instructions</i>	27
4.1	General	27
4.2	Mounting the Horizontal Arm Above the Magnet	27
4.3	Pneumatic Connections	28
4.4	Electrical Connections	31
4.5	Mounting the BSR Flexible Tube	34
	Assembling the BSR Flexible Tube	35
4.6	Mounting the BSR VAC Flexible Tube	38
	Assembling the BSR VAC Flexible Tube	39
5	<i>Settings and Adjustments</i>	41
5.1	General	41
5.2	Adjustment of the Sample Lift Air Flow (BSR only)	41
5.3	Adjustment of the Buffer Air for the Sample Lift (BSR only)	42
5.4	Adjustment of the Suction Air for the BSR VAC Sample Lift	42
5.5	Adjusting the BSR VAC Temperate Air Flow	43
5.6	Adjusting the Sample Down Unit for SampleRail	43
5.7	Adjusting the Sample Down Detector for BSR VAC	45
6	<i>Operating Instructions</i>	47
6.1	Front Panel Controls	47
6.2	Starting the System	47
6.3	Automatic Mode	48
6.4	Manual Insertion Mode	48
	Switching to Manual Insertion Mode	48
	Manual Insert	49
	Manual Eject	49
6.5	The Occurrence of a Failure	50
7	<i>Software Commands</i>	51
7.1	SampleRail™ Command Implementation	51
7.2	Operation Mode	52
	Standard Commands	52
7.3	Error Mode	59
7.4	Diagnostic Mode	60
8	<i>Communication with the Tecan Robot</i>	69
8.1	Introduction	69
8.2	Commands	69
9	<i>Error Handling</i>	73
9.1	Introduction	73
9.2	Error Messages	73
	Errors Requiring User Intervention	73
	Communication Errors	76
10	<i>Operator Maintenance</i>	77
10.1	Introduction	77

10.2	Cleaning	77
10.3	Greasing the Pneumatic Linear Drives	78
10.4	Cleaning After an NMR-Tube Breaks	79
10.5	Pivoting the SampleRail Horizontal Arm	79
10.6	Pivoting the BSR	81
	Pivoting the BSR VAC	83
10.7	Opening the BSR Cover	85
	Removing the BSR Covers	85
	Opening of the BSR VAC Hood	86
11	<i>Barcode Reader Option</i>	89
11.1	Introduction	89
	Operation without a Barcode Reader	90
	Operation with a Barcode Reader	90
11.2	The CCD Barcode Reader	90
11.3	The 2D Barcode Reader	91
12	<i>Standard Accessories</i>	93
12.1	BSR Accessories	93
	Sample Accessories	93
	Tool Accessories	94
12.2	BSR VAC Accessories	95
	Sample Accessories	95
	Tools Accessories	96
13	<i>Technical Data</i>	97
13.1	Power Supply Requirements	97
13.2	Fuse Protection	97
13.3	Compressed Air Requirements	97
13.4	Serial Communication	97
13.5	Noise Level	98
13.6	Environmental Requirements	98
	<i>Figures</i>	99
	<i>Tables</i>	101
	<i>Index</i>	103

Introduction

1

Bruker SampleRail

1.1

The SampleRail™ is part of a system, under the management of the SampleTrack™ Laboratory Information Management System (LIMS) and ICONNMR™ automation software, that provides automatic preparation and mixing of multiple compounds, and subsequent NMR measurements.

A typical application example is the protein-ligand binding detection by NMR. This system automatically prepares an NMR sample, inserts it into an NMR magnet, performs NMR experiments on the sample, and transports it back to the preparation system.

The SampleRail fulfills the transporting tasks from the preparation system into the NMR magnet and back, while a TECAN™ Genesis/Freedom pipetting robot is used as the preparation system. The SampleRail may also be used in a "manual insertion mode" to insert and eject single NMR samples manually into the NMR magnets.

SampleRail may also be used in a 'manual insertion mode' to insert / eject single NMR samples manually into the NMR magnet.



Figure 1.1. The BRUKER SampleRail and the TECAN Robot

About This Manual

1.2

This manual is included with the delivery of the SampleRail™ system and provides instructions on how to:

- install and configure the SampleRail system;
- operate the system.

This manual applies to the SampleRail basic version - from this point on referred to as the BSR. It also applies to the SampleRail system with a vacuum unit, which is available in either left or right orientated.

- BSR = Bruker SampleRail
- BSR VAC = Bruker SampleRail VAC left / right

The term SampleRail includes all the above mentioned versions.

Trademarks

1.3

All product names and marks mentioned in this document are trademarks or registered trademarks and property of their respective owners.

SampleRail™ is a trademark of Bruker BioSpin GmbH.

TECAN product names are trademarked products or registered trademarks of TECAN Group Ltd.

Warnings and Notes

1.4

There are two types of information notices used in this manual. These notices highlight important information or warn the user of a potentially dangerous situation. The following notices will have the same level of importance throughout this manual.



Note: Indicates important information or helpful hints



WARNING: Indicates the possibility of severe personal injury, loss of life or equipment damage if the instructions are not followed.

For further technical assistance on the SampleRail system, please do not hesitate to contact your nearest BRUKER dealer or contact us directly at:

BRUKER BIOSPIN GMBH
Silberstreifen
D-76287 Rheinstetten
Germany

Phone: + 49 721 5161 0
FAX: + 49 721 5171 01
E-mail: nmr@bruker-biospin.de
Internet: www.bruker-biospin.de/nmr/

Safety Considerations

2

Read these safety instructions carefully and make them accessible to anyone working around the SampleRail system. A SampleRail system can be operated easily and safely provided the correct procedures are followed and certain precautions observed.

Disclaimer

2.1

Bruker is not responsible or liable for any injury or damage that occurs as a consequence of non-approved manipulations on the SampleRail system.

Important Safety Considerations

2.2

-
- The power supply voltage must correspond to the information listed in "**Power Supply Requirements**" on page 97.
 - The compressed air supply must correspond to the specifications listed in "**Compressed Air Requirements**" on page 97.
 - Never touch any moving parts, always wait until the device has come to a complete stop.
 - Please note that in **automation mode** the device may restart unexpectedly.
 - In case of malfunction during operation, stop the device, disconnect the power supply and inform customer service.
 - Always use original manufacturer accessories.
 - Do not use the device if the power cord, compressed air hose, or the device itself have visible damage.
 - Inappropriate or improper repairs may result in personal injury to the user. **Never disassemble the device or try to repair it.** Repairs and disassembly should only be carried out by experienced technicians.

Operational safety can only be guaranteed if SampleRail is used properly. SampleRail offers two modes of operation:

Manual Insertion Mode: Manual insertion/ejection of NMR samples is controlled by the front panel buttons of the SampleRail control unit.

Automatic Mode Automatic insertion/ejection of NMR samples is remotely controlled by the spectrometer host computer, as described in the chapter "**Operating Instructions**" on page 47.

Appropriate usage of the device includes reading this manual and observing all recommendations - especially all safety aspects.

All service and routine maintenance must be performed within the prescribed time intervals as outlined in "**Operator Maintenance**" on page 77. Failure to do so will be considered improper use of the product and will invalidate any warranties.



If the SampleRail is used in any way other than for what it was intended, as outlined in this manual, this will constitute 'unauthorized use'. Bruker is not responsible or liable for any injury or damage that occurs as a consequence of improper or unauthorized usage of the SampleRail system.

The SampleRail system may only be operated by trained and authorized personnel. All personnel who work with, or in the close proximity of a SampleRail system, need to be informed of all safety issues and emergency procedures as outlined in this user manual.

Technically Qualified Personnel Only

The transportation, mounting, start-up, instruction, maintenance, cleaning, service, repair and shutdown of the SampleRail system should only be carried out by trained, qualified and authorized personnel.

New users must be supervised by experienced personnel! It is highly recommended that a company training program be implemented for training new users on all aspects of product safety and operation.

Hazards from Samples, Breakage of Glass... and Other Substances**2.3.2**

- When operating SampleRail using glass tubes, there is always a danger present when using samples with chemical or biological substances and solvents.
- Always use undamaged glass tubes. Damaged glass tubes need to be exchanged immediately.
- When operating the BSR VAC only use 4.25x100mm glass tubes with the corresponding sample holder (tube, septum, barcode label).
- The user's organization is responsible for taking measures to avoid inherent risks in the handling of dangerous substances, preventing industrial disease, and providing medical first aid in emergencies.
- The user's organization is responsible in providing facilities and making disposition according to the local regulations for the prevention of industrial accidents and generally accepted safety regulations according to the rules of occupational medicine.
- All substances needed for operating and cleaning the device - samples, solvents, cleaning agents, gases, etc. have to be handled with care and disposed of appropriately. All hints and warnings on storage containers must be read and adhered to!
- The use of glass tubes may result in cuts and stab wounds if a tube should be damaged. Therefore, appropriate care and diligence must be observed when using these devices.

Availability of Information**2.3.3**

This SampleRail user manual must be kept with the device. All personnel operating the device must have access to the SampleRail user manual at all times.

In addition to the SampleRail user manual, instructions concerning labor protection laws, operator regulations tools and supplies must be available and be adhered to.

All warning and user information labels must be kept in a good and fully readable status. Unreadable or damaged labels should be replaced immediately.

The following markings on the SampleRail must be observed:

- Warning symbols,
- Labeling for electric and compressed air connections.

These markings should always be maintained in a fully readable condition.

Before the First Start**2.3.4****Familiarize yourself with:**

- The operating and control elements.
- The instrumentation.
- The mode of device operation.

Safety Considerations

- The device's environment.
- The safety arrangements of the device **„Opening the BSR Cover“ on page 85.**
- All emergency procedures (**operating company**).

Activities Before Each Start

2.3.5

Before every start the following activities are to be executed:

- Examine and ensure that all security devices (hoods/enclosures) are appropriate and in working condition.
- Visible observe the device for any obvious damage; observed defects have to be eliminated immediately and/or reported immediately to the responsible party - SampleRail should only be used when in fully operational condition.
- Check and ensure that only authorized personnel remain in the work area during operation and that no one is at risk when the device is started.
- All objects and materials that are not required for the operation mode should be removed from the work area.

Normal Operation

2.3.6

During operation no security devices should be removed or switched off.

The user must observe that no unauthorized people remain in the SampleRail work area.

During operation of the device in Normal Mode the following special hazards can arise:

- Inappropriate use of the device in combination with dangerous or infectious samples and solvents may result in a life-threatening situation. Laboratory and general safety instructions (**operating company**) for the care, handling and use of substances and samples have to be observed without restriction at all times.
- Inappropriate reaction to hazardous incidents may result in personal injury and damage to property - be familiar with the company regulations on handling hazardous incidents.

Maintenance

2.3.7

Before and during the service maintenance the following rules have to be considered:

- Switch off the electrical power supply on the back of the BSR Control Unit.
- Operating personnel must observe that no unauthorized people remain in the SampleRail work area.
- Change faulty parts of the device immediately.
- Use only original manufacturer spare parts.

- Storage tanks must be available for substances that might cause ground water pollution.

After the service maintenance and before a new start of the device the following rules have to be considered:

- Verify that all screws/bolt connections which were loosened have been retightened correctly.
- Check, that all protection devices and hoods have been replaced properly.
- Verify that tools, materials and other equipment used have been removed from the work area.
- Clean the work area and remove any leaking fluids and lubricants.
- Verify that all protection devices are working correctly.

Detailed maintenance guidelines for each of the individual components of SampleRail within this manual should also be adhered to.

Cleaning

2.3.8



Use only water or mild neutral cleaning agents for cleaning. Usage of a diluter or gasoline will damage the surface of the device.

When cleaning the device the following guidelines must be followed:

- Switch off the electrical power supply on the back of the BSR Control Unit and unplug the mains cable before cleaning.
- Clean the device with a dry or moist cloth.
- Dry the device completely before plugging in the mains cable.

Replacement Parts

2.3.9

For safety reasons the device must not be modified without pre-authorization in writing from Bruker.

Use only Bruker original spare parts and accessories. These parts are especially designed for the device.

Parts and equipment, that are not supplied by Bruker, are not authorized for use, and no guarantee is given for the compatibility and safety of these products.

Bruker takes no responsibility for consequences arising from the use of unauthorized parts and equipment.

The installation, replacement, and relocation of SampleRail should only be carried out by authorized Bruker personnel.

Consult Bruker customer service for information on the disposition of SampleRail.

SampleRail was constructed and built *state-of-the-art* based on a complete safety analysis and harmonized standards.

The proven level of safety can only be obtained when the operator takes reasonable precautions. It is the operator's due diligence to make all necessary safety precautions and continuously control them.

The operating company has to ensure that:

- SampleRail is used only in accordance with established regulations.
- The device is used only in proper operational condition and that the safety measures are checked at regular intervals.
- All warning notices and safety instructions attached to the device, stay readable.
- The operational manual stays in a readable state and is available at the usage site.
- Only qualified and authorized personnel operate, maintain and repair the device.
- All personnel are instructed regularly in all applicable industrial safety and environmental protection standards, as well as the information contained within this manual, especially all references to safety.
- All necessary safety equipment for operation, maintenance, and repair are available and are utilized.
- A safety evaluation be routinely conducted to further identify whether any local or special conditions exist that may effect the working conditions and/or safety of users.
- The results of the safety evaluation be summarized and posted in the work area to inform personnel of potential risks.

Potentially Hazardous Areas**2.5****Moving parts****2.5.1**

SampleRail is driven by compressed air, even with control unit turned off, there can still be pressure in the cylinders. **Thus unexpected movement of the trolley is possible.**



During operation avoid putting hands or objects into the moving parts of the SampleRail, as this may cause personal injury or damage to the equipment.

The BSR is covered with a hood at the transfer unit on the robot side and at the magnet to prevent damage to the BSR and to prevent personal injury.

The BSR VAC is covered with an enclosure which protects the entire path of the trolley.



Do not open the hood/enclosure when SampleRail is operating. Opening of the hood/enclosure does not interrupt the trolley movement.

Repair work that requires a trolley movement with the hood/enclosure opened, should be done only by authorized technical personnel.

The following warning symbol is located on the hoods/enclosures:



Figure 2.1. Warning Symbol at the Hood/Enclosure of SampleRail

Safety Considerations

Alternatively the following warning symbol may be appropriate at the access points of the SampleRail trolley:



Figure 2.2. Alternative Warning Symbol on SampleRail

Electrical parts

2.5.2

The SampleRail control unit is driven by line voltage. If the control unit has to be opened for service or repair disconnect the mains cable before opening.



Inside the SampleRail control unit live parts are not covered. Coming in contact with them may result in personal injury!

Remember that all service must be done by trained service personnel only.

The following warning symbol is found at the rear panel of the SampleRail control unit:

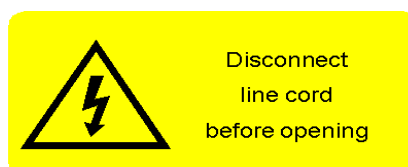

Figure 2.3. Warning Label at the Rear Panel of the SampleRail Controller

System Description

3

The SampleRail System

3.1

The SampleRail system consists of the subassemblies shown in the figure below:

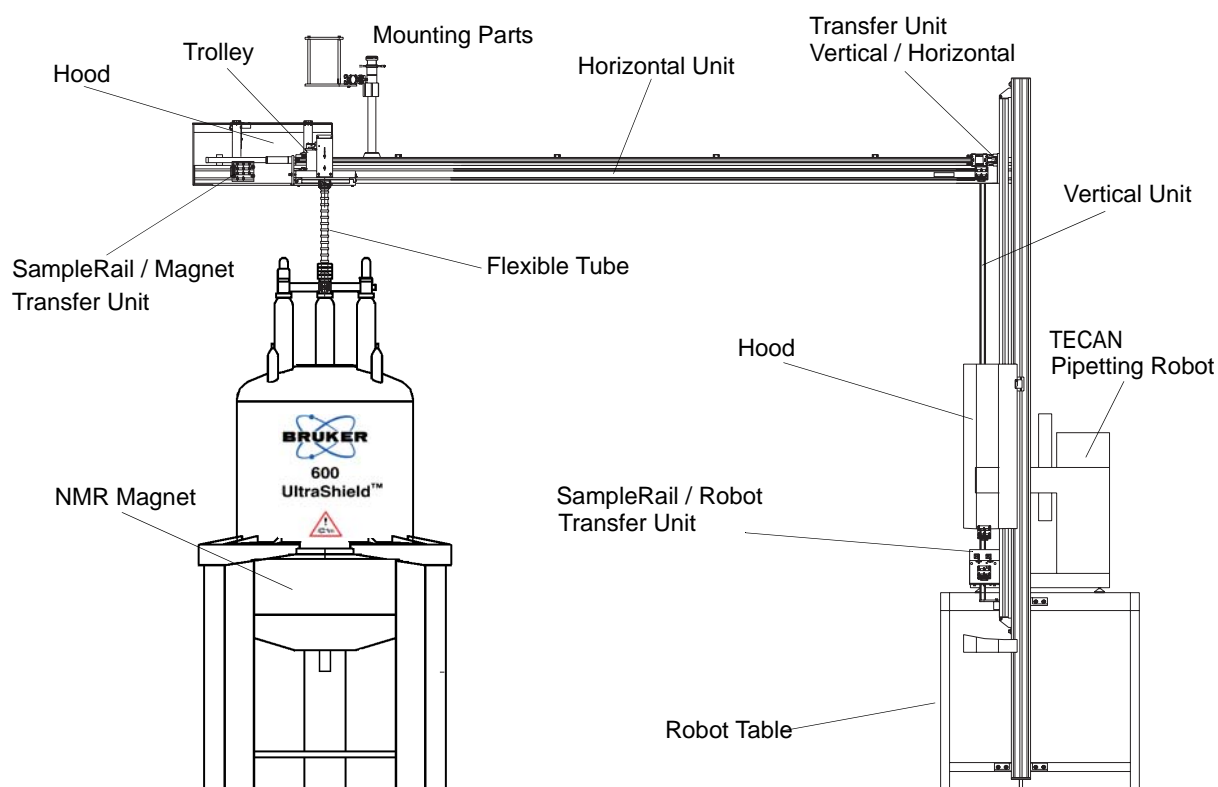

Figure 3.1. The Bruker SampleRail System

Horizontal and Vertical Units

The motion of the SampleRail trolley is provided through pneumatic cylinders which make up the main parts of the horizontal and the vertical units.

The length of the horizontal and vertical units may vary according to the individual needs in the customers laboratory layout.

The SampleRail/Robot Transfer Unit

The TECAN® pipetting robot places/removes prepared samples from the insert/eject position of the trolley at the SampleRail/robot transfer unit.

The Transfer Unit Vertical/Horizontal

The sample is passed from the horizontal unit to the vertical unit trolley (and vice versa) at the transfer unit vertical/horizontal.

The SampleRail/Magnet Transfer Unit

SampleRail is connected to the shim upper part of the NMR magnet from the SampleRail/magnet transfer unit via a flexible tube. The samples may be inserted into or ejected out of the magnet pneumatically through this tube. The tube's flexibility guarantees the decoupling of the magnet and the SampleRail, which helps prevent interference from mechanical oscillations.

Sample Trolley

The sample trolley transports the samples and consists of two positions for the sample tubes:

- the insert position for new samples (marked with an 'I');
- the eject position for pre-measured samples (marked with an 'E').

The advantage of having two positions is that a sample exchange can be completed without a major loss of time.

Fixing and Mounting Parts

The various parts which are needed to fix the horizontal and vertical units depend on the individual laboratory and building layout, and thus are customer specific.

SampleRail Control and Pneumatic Unit

The SampleRail control unit and the pneumatic unit are both 19" racks which are mounted in the cabinet of the TECAN® robot. These units control SampleRail and provide communication between the TECAN® and the spectrometer, where the main automation management software runs.

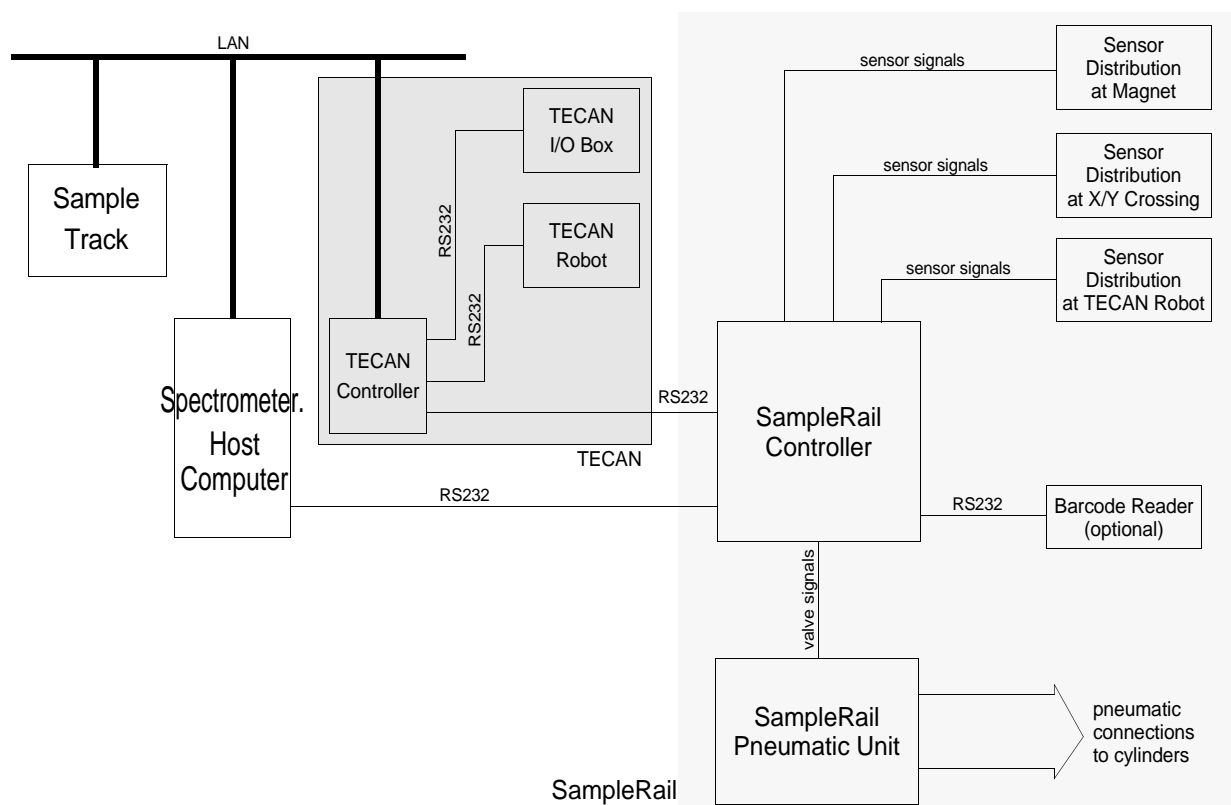

Figure 3.2. SampleRail Communication Block Diagram



Figure 3.3. Example of a SampleRail System

The BSR VAC is a customized SampleRail system. It allows the handling of special sample holders, whereas the tube is closed with a septum and is provided with a barcode label. An optimized TECAN® Freedom robot is integrated into the system.

As opposed to the normal BSR, the BSR VAC draws the measured sample into the trolley/carrier with the help of a vacuum unit, rather than blowing it out of the magnet.

Communication between the BSR control unit, spectrometer host computer, and TECAN® robot is based on the same command language as with BSR.

The basic differences between the BSR and the BSR VAC are that the BSR VAC system contains:

- A new sample trolley adapted for use with the new sample holder.
- A vacuum unit is located within the transfer unit above the magnet.
- A special shim upper part is used.
- A new sample detection unit is used to detect the sample in the magnet.
- A hood is used to seal the entire transport system.



Figure 3.4. Example of a BSR VAC System

Where to Find the Type Label

3.3

You will find the SampleRail type label on the lower end of the vertical linear drive.

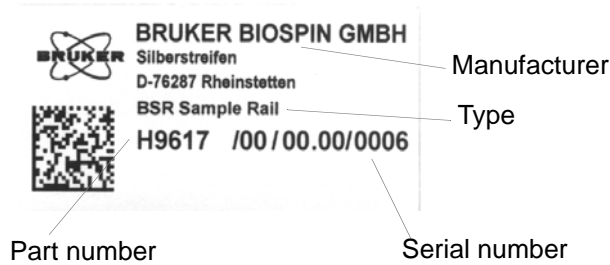

Figure 3.5. The BSR SampleRail Type Label

The SampleRail controller type label is attached to the back panel.

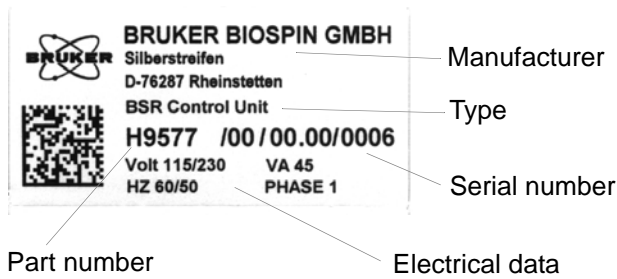

Figure 3.6. The BSR Control Unit Type Label

The Pneumatic Unit type label is also attached to the back panel.

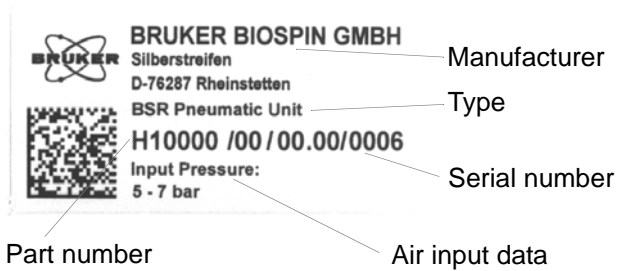

Figure 3.7. BSR Pneumatic Unit Type Label

Installation Instructions

4

General

4.1

SampleRail™ can only be installed by trained BRUKER service personnel. A few installation examples are described in this chapter to illustrate typical installation scenarios.

Mounting the Horizontal Arm Above the Magnet

4.2

Because of the transmission of vibrations to the magnet, no fixed support of the SampleRail horizontal arm to the magnet is possible. Therefore, to support the weight of the horizontal arm, normally it is necessary to fasten it to the ceiling. The mechanical parts and their fixation are planned by BRUKER based on the sites individual requirements.

The structural requirements and fixation of these parts at the building site are the responsibility of the customer.



Figure 4.1. Attaching the Horizontal Arm

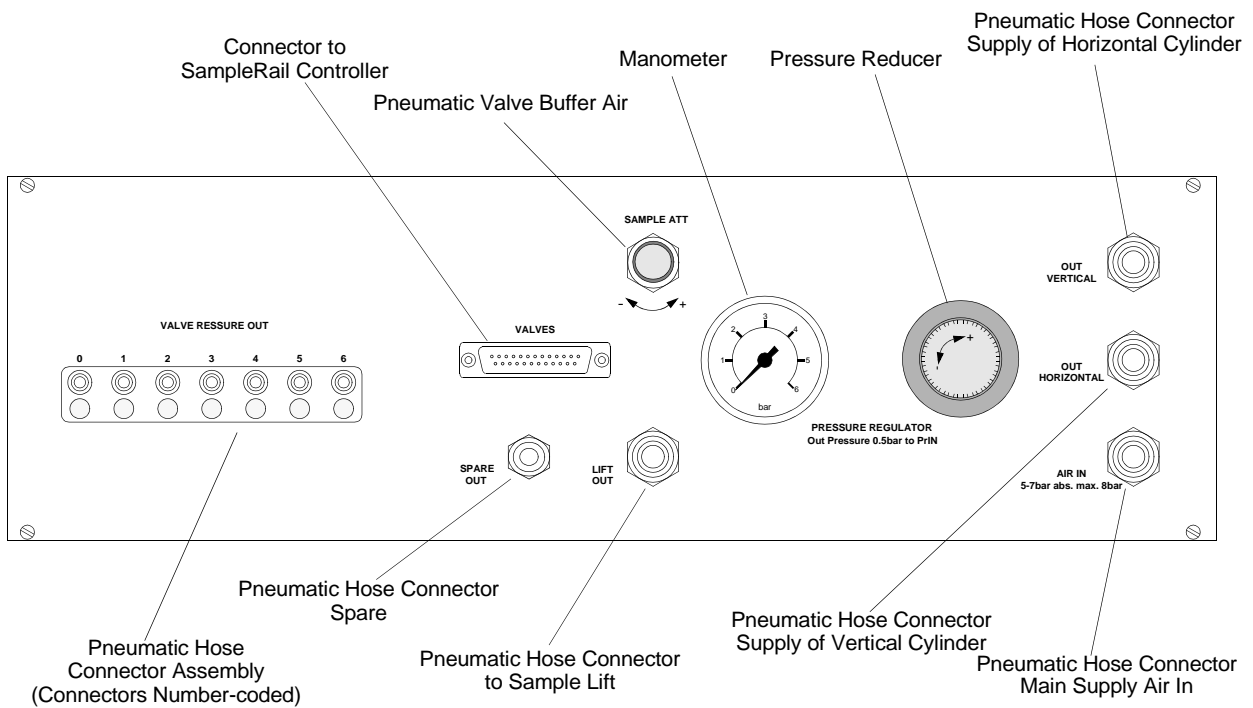
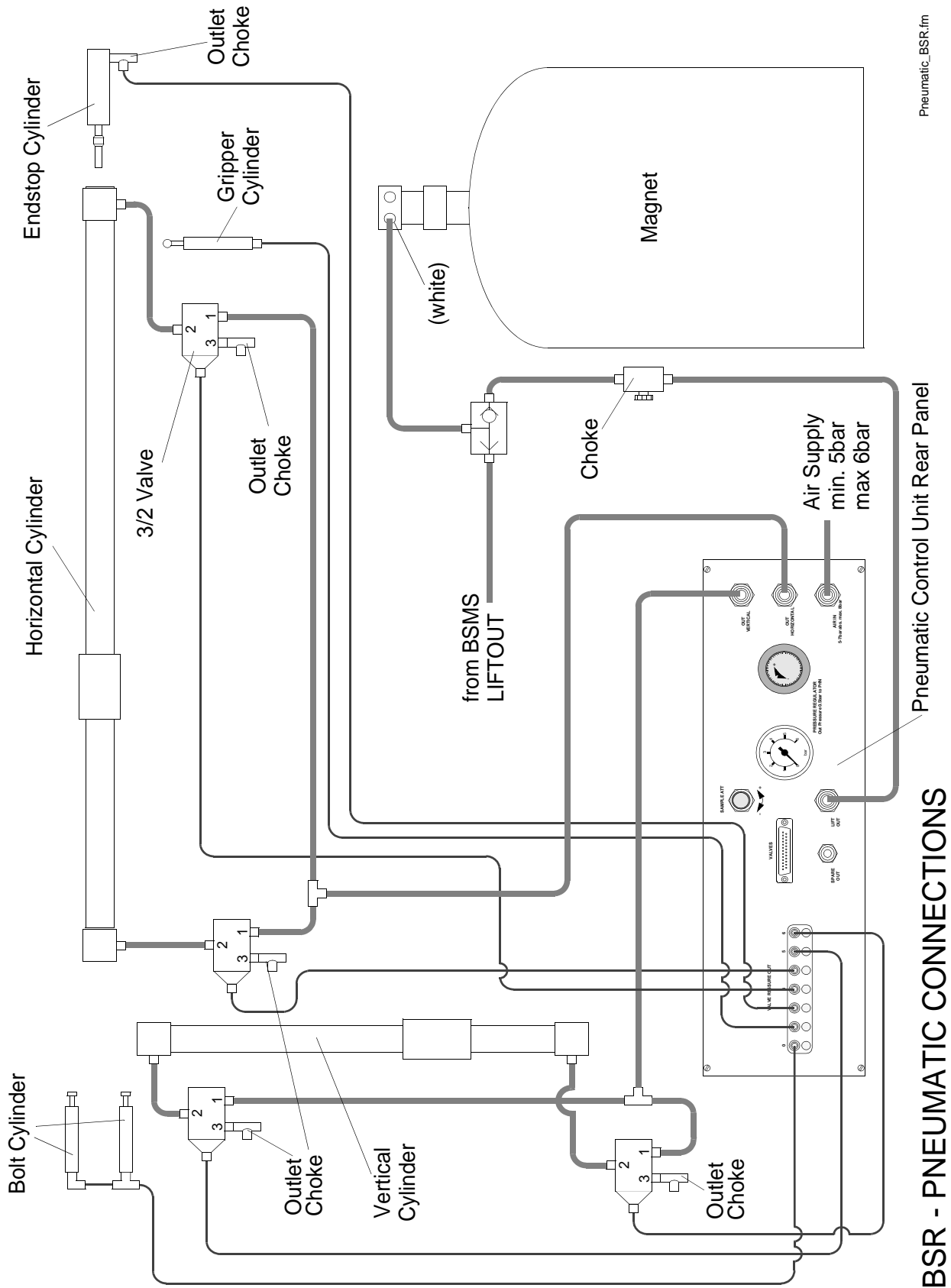

Figure 4.2. Pneumatic Unit Rear Panel



The customer is responsible in providing a compressed air connection with a separator and a compression delimiter unit according to EN983. The maximum air pressure is 8 bar or 116 pound-force/square inch (PSI). See "[Compressed Air Requirements](#)" on page 97.

The system must be depressurized prior to disconnecting hoses, which will prevent hose backlash.



Pneumatic_BSR.fm

BSR - PNEUMATIC CONNECTIONS

Figure 4.3. BSR Pneumatic Connections

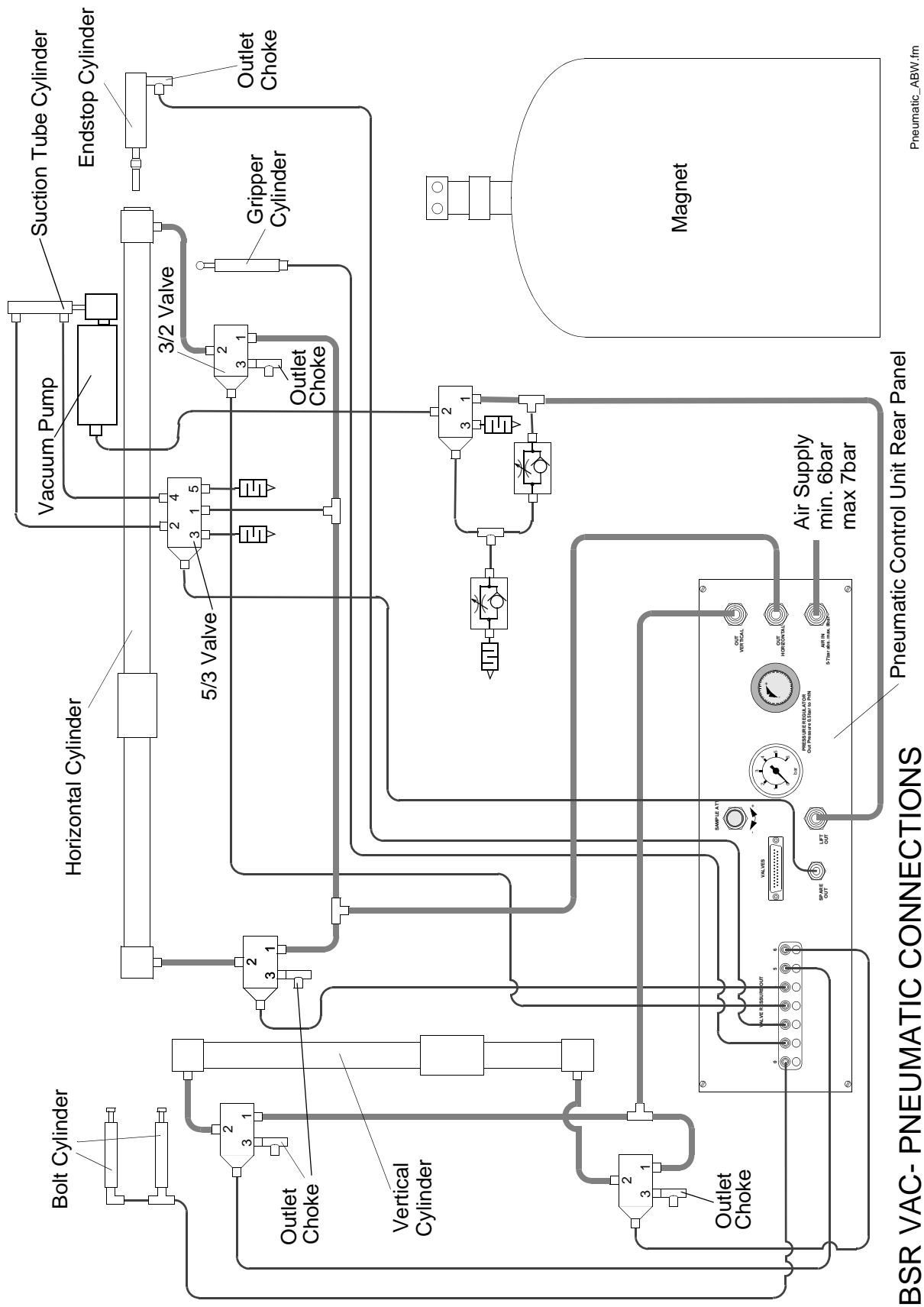

Pneumatic_ABW.fm

Pneumatic Control Unit Rear Panel

BSR VAC- PNEUMATIC CONNECTIONS

Figure 4.4. Pneumatic Connections BSR VAC

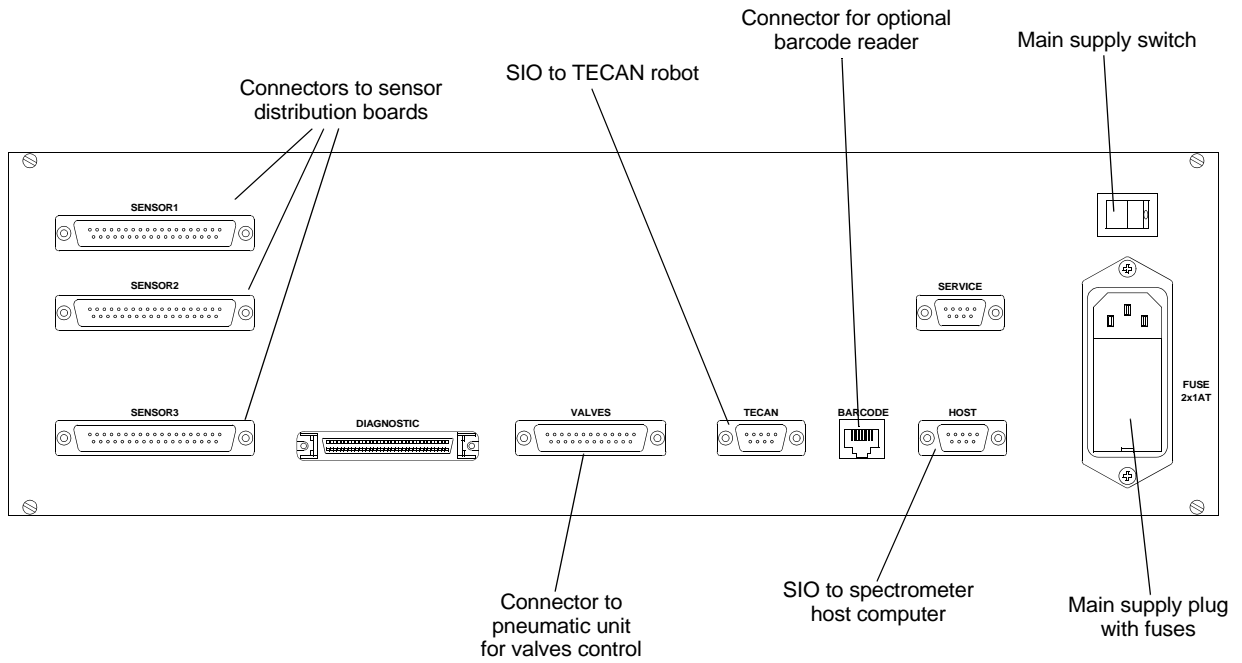
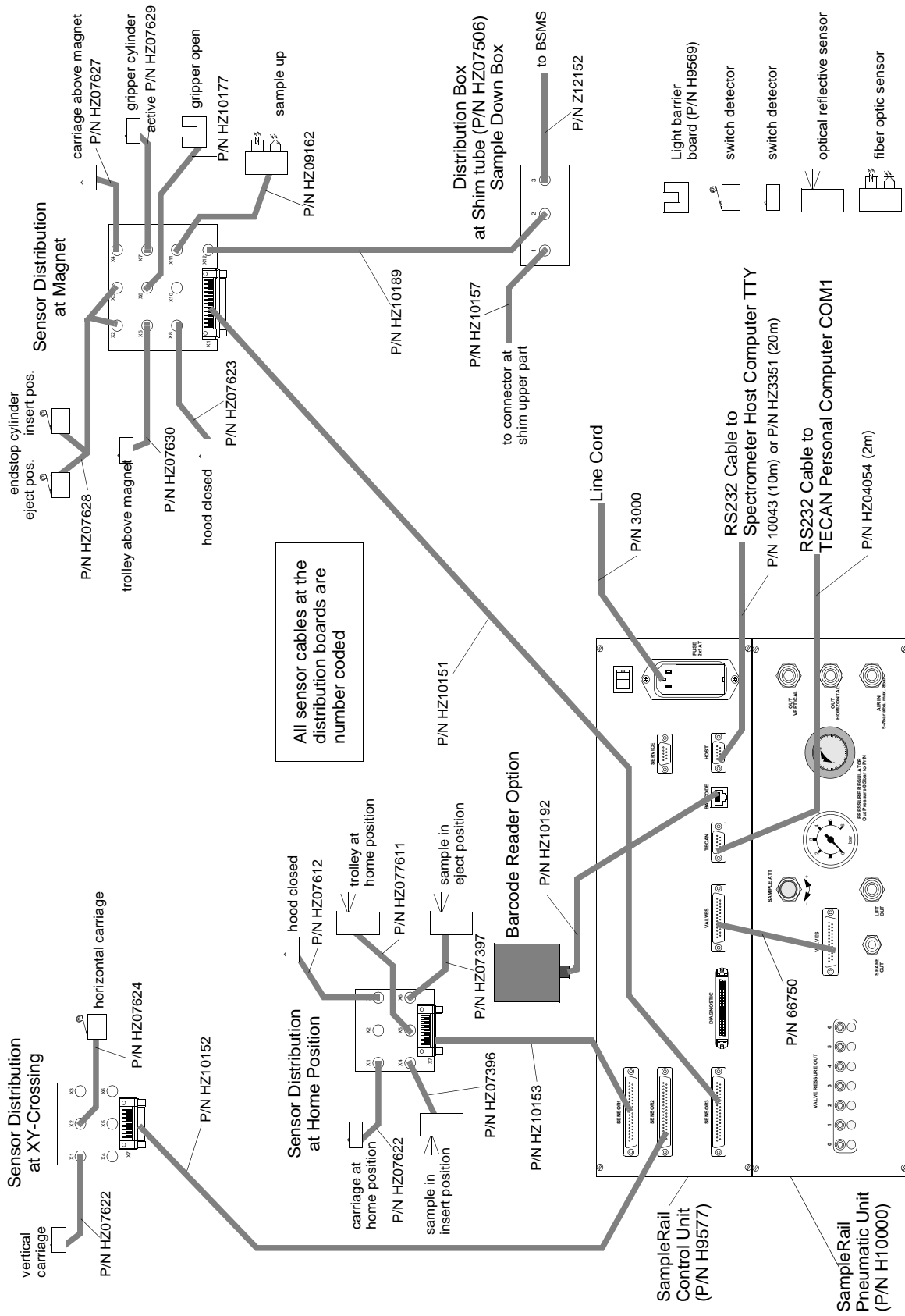

Figure 4.5. Control Unit Rear Panel



wiring_BSR.fm

Figure 4.6. Electric Connections BSR

BSR - ELECTRICAL WIRING

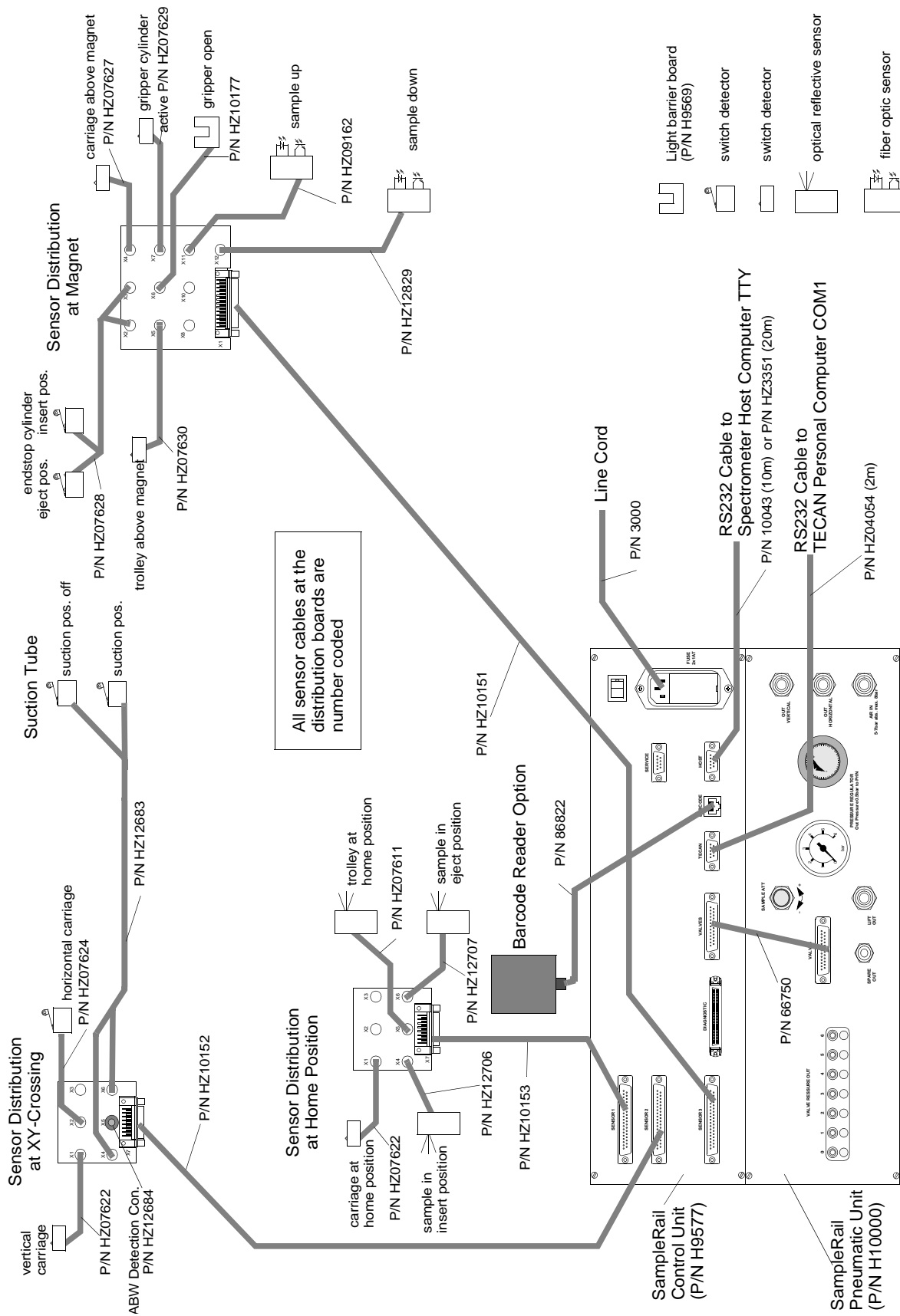

Figure 4.7. Electric Connections BSR VAC

BSR VAC - ELECTRICAL WIRING

wiring_ABW.fm

Mounting the BSR Flexible Tube

4.5

The BSR flexible tube connection to the magnet is manufactured according to the length required at the installation site. The quantity of the tube rings (P/N HZ07874) depends on the flexible tube's length.

For optimal and safe sample transportation this tube must not be bent.

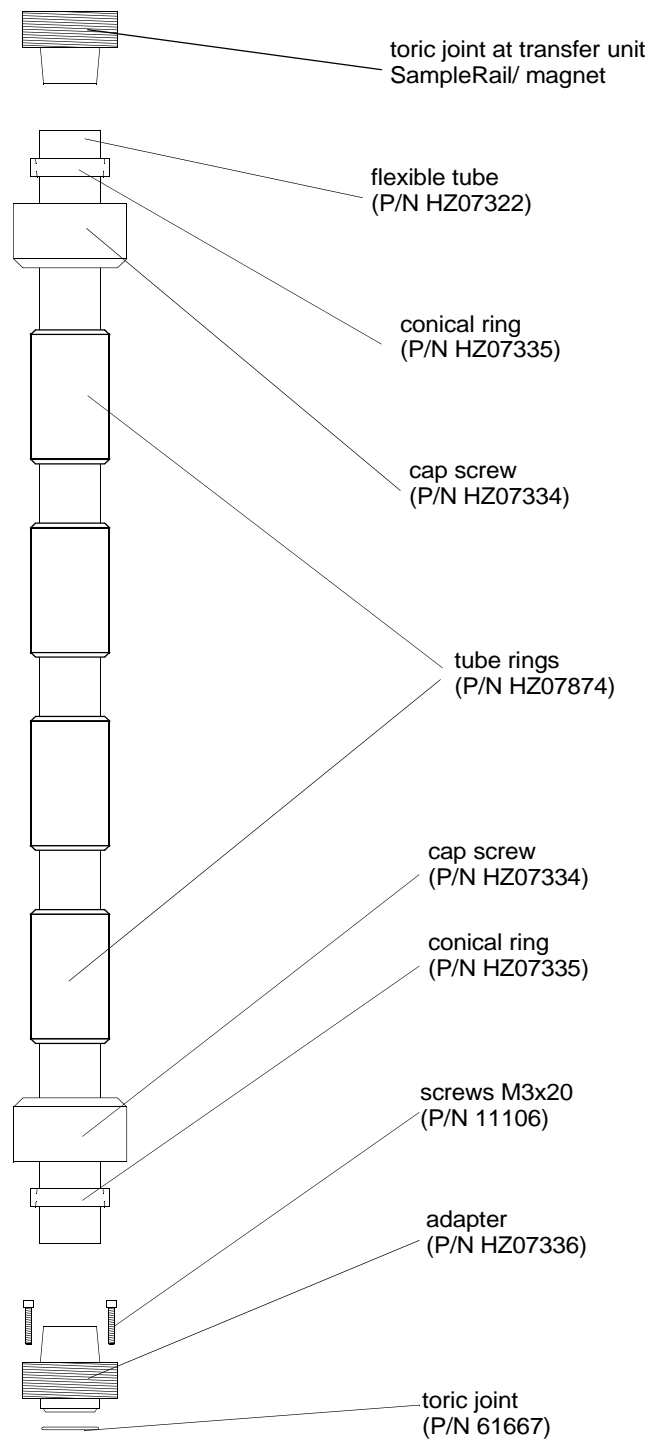

Figure 4.8. BSR Flexible Tube Components at the Shim Upper Part

Assembling the BSR Flexible Tube



1. Remove the ball head screws on top of the shim upper part.



2. Fix the toric joint to the bottom of the tube adapter.



3. Put the adapter onto the top of the shim upper part.



4. Insert the adjusting device found in the tool set with the standard accessories.

Installation Instructions



5. Fix the adapter with the M3x20 screws and take out the adjusting device. The adjusting device should slide out easily.



6. Assemble the tube. Shift the tube rings onto it first, then the cap screw and at least the conical ring. The conical ring has a bright edge and a dark edge. The dark edge should be on the top.



7. Put the tube into the adapter.



8. Slide the conical ring downwards.



9. Fix the tube with the cap screw.



10. Arrange the tube rinds along the complete length of the tube.

Mounting the BSR VAC Flexible Tube

The BSR VAC flexible tube connection to the magnet is manufactured according to the length required at the installation site. The quantity of the tube rings (P/N HZ07874) depend on the length flexible tube's.

To reach a safe sample transportation it must not be bent.

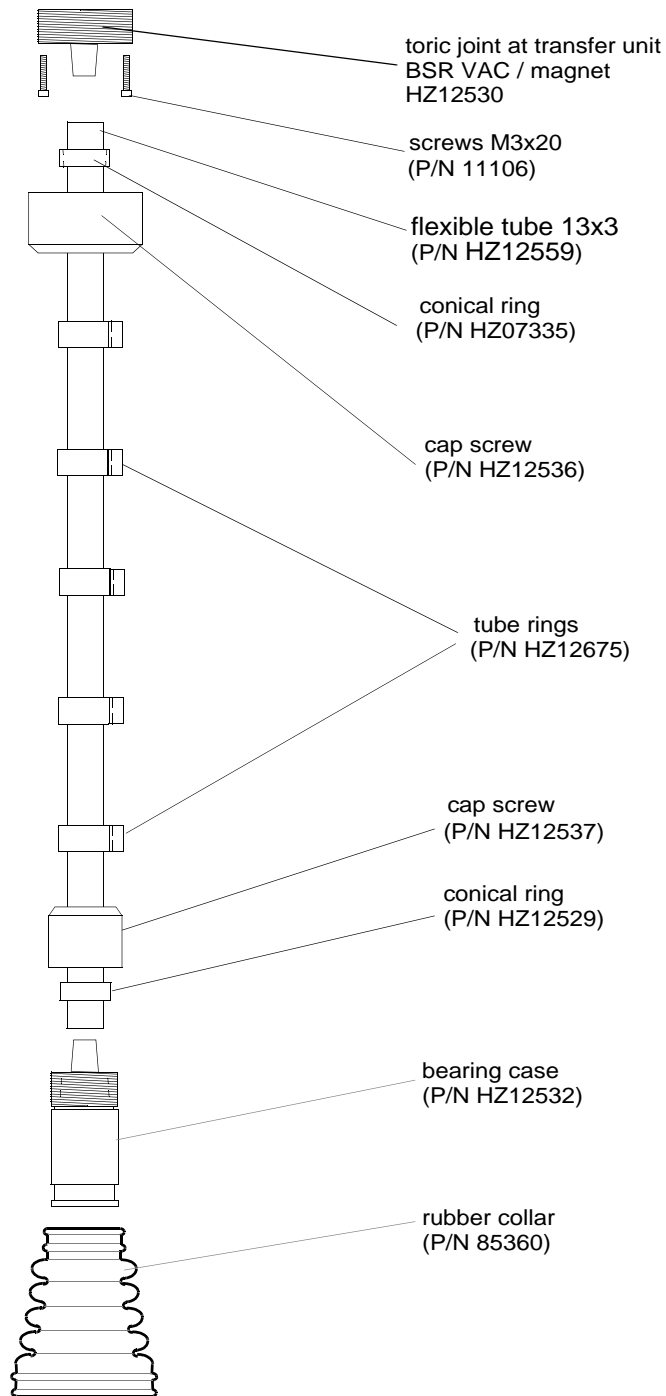

Figure 4.9. BSR VAC Flexible Tube Components at the Shim Upper Part

Assembling the BSR VAC Flexible Tube



1. Put the upper part of the tube onto the adapter at the toric joint. Slide the conical ring over the tube towards the adapter. Fix the tube with the cap screw.



2. Slide the cap screw on the hose with the large opening to the outside. Slide the conical ring onto the tube. Place the lower part of the tube onto the adapter at the bearing case. Slide the conical ring to the adapter. Fix the tube with the cap screw.
3. Assemble the rubber collar on the bearing case. Slide the rubber collar bottom-up over the bearing case.

Installation Instructions



4. Place the rubber collar on the shim upper part. For the BSR VAC a special shim upper part is used.



5. Slide the rubber collar top down over the shim upper part. Then arrange the tube rings along the complete length of the tube.

Settings and Adjustments

5

General

5.1

SampleRail settings and adjustments must be done by trained service personnel. Damages resulting from improper adjustments by untrained personnel are the customers responsibility.

Adjustment of the Sample Lift Air Flow (BSR only)

5.2

The valve to adjust the lift air flow is located at the top of the magnet.

- For faster sample lift turn the valve counter clockwise (open).
- For slower sample lift turn the valve clockwise (close).

Always adjust the settings in small steps and observe the effects each time during a sample change before proceeding.

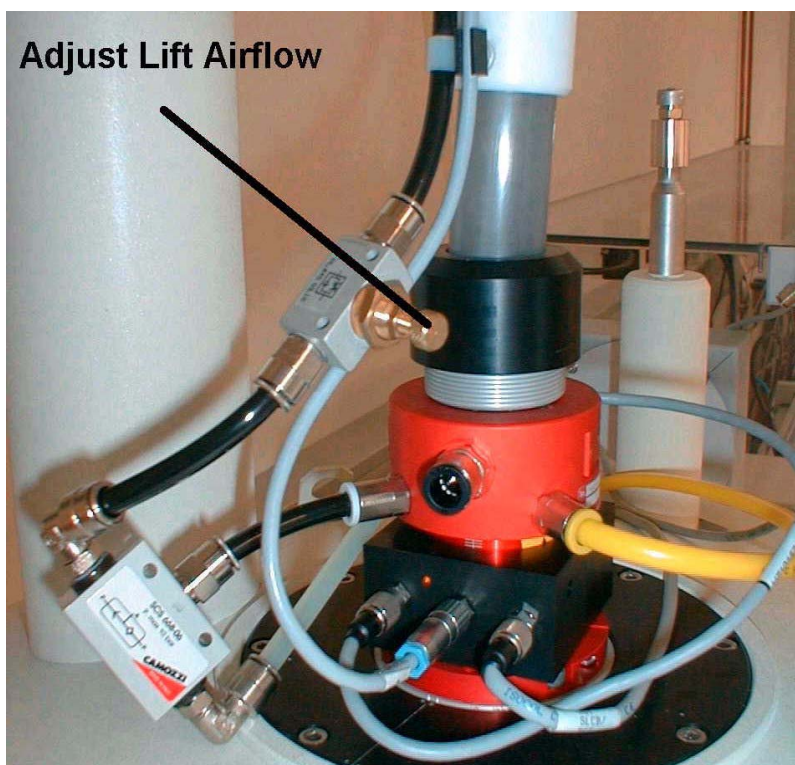

Figure 5.1. Valve to Adjust Lift Air Flow

Adjustment of the Buffer Air for the Sample Lift (BSR only)

5.3

The valve to adjust the air flow from the buffer tank, which is used to control the lift, is on the rear side of the BSR pneumatic unit.

- To lower the sample faster: Turn the valve in clockwise direction (close).
- To lower the sample slower: Turn the valve in the counter clockwise direction (open).

Always adjust the settings in small steps and observe the effects each time during a sample change before proceeding.



Figure 5.2. BSR Pneumatic Unit - Rear Side

Adjustment of the Suction Air for the BSR VAC Sample Lift

5.4

The strength of the low pressure used to pull the BSR VAC sample must be adjusted using the input pressure of the BSR Pneumatic Unit.

The input pressure of the suction unit (BSR Pneumatic Unit - LIFT OUT) is not restricted by the BSR Pneumatic Unit valve.

The customer is responsible for provide a compressed air supply with an adjustable pressure regulating valve for the BSR VAC.

The pressure needed here is 6,5 bar with an air consumption volume of about 100 l/min. The pressure should be adjustable from 6 - 7 bar.

Adjust the pressure of the regulating valve at the installation site:

- For faster sample removal: Increase the pressure.
- For slower sample removal: Lower the pressure.

Always adjust the settings in small steps and observe the effects each time during a sample change before proceeding.

Adjusting the BSR VAC Temperate Air Flow

5.5

In order for the sample to optimally reach its measurement position in the magnet during insertion (INSERT), the real temperate air flow rate should be a maximum of 350 l/h. To adjust this with XWIN-NMR or Topspin (edte) only the values 135 l/h or 270 l/h are permissible. We recommend selecting 270 l/h.

We also recommend that the real temperate air flow rate be checked by Bruker service during the installation and when problems with the insertion of the sample into the magnet occur.

The air flow should be measured between the BVT module of the spectrometer and the probe using a flow meter. The measure value must agree with the values given in XWIN-NMR (edte).

An adjustment of the air flow can be made at the pressure control valve on the back of the BVT module if necessary (make calibration for 270 l/h).

Adjusting the Sample Down Unit for SampleRail

5.6

Two versions of the sample down unit have been used for SampleRail. These differ in their housing color. The adjustment is carried out in connection with the applied shim upper part. When replacing either the sample down unit or the shim upper part, the settings have to be readjusted. The adjustment range is different for both versions.

1. The BSR Sample Down Unit (**P/N HZ07506 ECL 00**) was used until 2003. It has a black housing. The adjustment range in connection with the applied shim upper part is not sufficient in certain cases. If necessary, this older unit can be exchanged for the newer **BSR Sample Down Unit with ECL 01**.

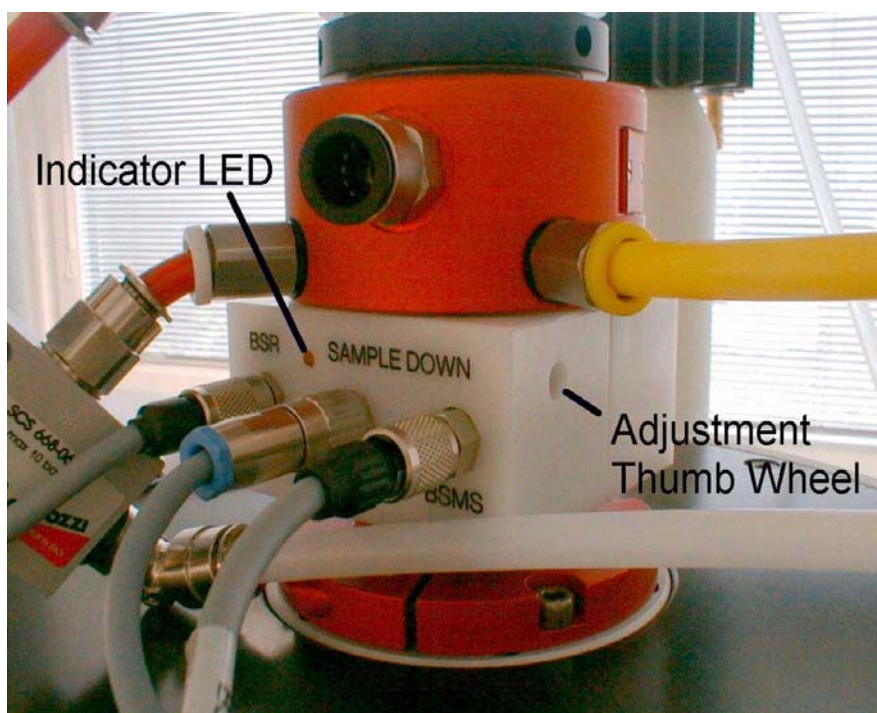

Figure 5.3. BSR Sample Down Unit ECL 00

2. Since 2004 the BSR Sample Down Unit (**P/N HZ07506 ECL 01**) with a white housing has been used.



Figure 5.4. BSR Sample Down Unit ECL 01



1. Remove the sample from the magnet.
2. Turn the adjustment thumb wheel clockwise until the orange sample down indicator LED is on.
3. Turn the adjustment thumb wheel slowly counterclockwise until the orange sample down indicator LED turns off. Turn two more turns upwards (counterclockwise).

Figure 5.5. Adjusting the BSR Sample Down Unit

- The BSR Sample Down Unit (P/N HZ07506 **ECL 01**) is also used in conjunction with the **BSR VAC** device. This unit verifies if a sample is in the magnet or not. An extra adjustment is not necessary. The fine tuning adjustment is done with the Fiber Amplifier Sample Down (HZ12829).

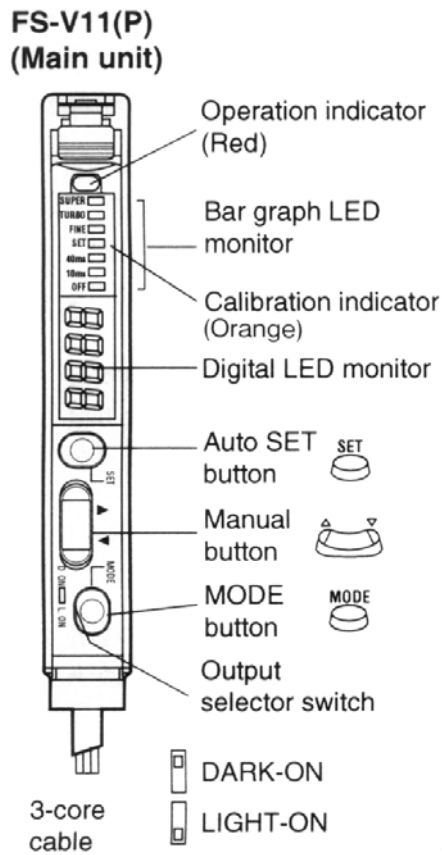

Two-point Calibration

1. Remove the sample from the magnet. Press the SET button and release it (The orange LED should light).
2. Position a sample in the magnet. Press the SET button again and release it.
3. The setting value is now adjusted to the midpoint of the difference in the received light intensity when the sample is absent and present.

Figure 5.6. Adjusting the Sample Down Fiber Amplifier

Operating Instructions

6

Front Panel Controls

6.1

The following controls are located on the front panel (see):

1. **LIQUID CRISTAL DISPLAY:** Used to display the current status and error messages.
2. **RESET:** A push button for system initialization.
3. **CONT:** A push button for continuation after a failure.
4. **EJECT:** A push button to start sample eject in manual insertion mode.
5. **INSERT:** A push button to start sample insertion in manual insertion mode.

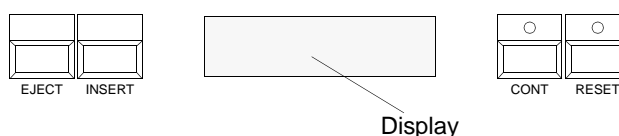

Figure 6.1. The BSR Control Unit Front Panel

Starting the System

6.2

Before starting the system ensure that the input pressure of the SampleRail Pneumatic Unit is set to the values shown in "**Compressed Air Requirements**" on **page 97**, and that all the SampleRail hoods and enclosures are closed.

Start the system by switching on the mains power switch on the rear panel of the SampleRail Control Unit (see **Figure 4.5. Control Unit Rear Panel on Page 31**).

The SampleRail initialization starts and the trolley moves into its home position (at the preparation robot). During initialization you should see the following display:

SAMPLE RAIL
INITIALIZATION

When SampleRail is already on you can trigger the initialization by pushing the RESET button on the SampleRail control unit's front panel.

Operating Instructions

When the SampleRail system initialization is finished and the trolley has reached its home position the following is displayed:

```
*   BRUKER   *  
*  SAMPLE RAIL  *
```

SampleRail is now ready to work in automatic mode.

Automatic Mode

6.3

In automatic mode the SampleRail is controlled by the IconNMR and SampleTrack software on the spectrometer host computer. To learn more about these software tools refer to the individual IconNMR (P/N H9199) and SampleTrack manuals.

The communication between the spectrometer host computer and the SampleRail control unit (via RS232 connection) is described in "**Software Commands**" on **page 51**.

Manual Insertion Mode

6.4

With SampleRail you have the opportunity to insert or eject samples manually without automation running.

Switching to Manual Insertion Mode

6.4.1

To enter manual mode you must first push the stop button for automation mode in ICON-NMR. To switch to manual insertion mode push both the EJECT and the INSERT button and hold for about two seconds until you see the following display:

```
MANUAL INSERTION  
MODE
```



Switching to manual insertion mode is only possible if the automation is not running.

During automation, the manual insertion mode is inhibited. When the system is in manual insertion mode it switches back to automation mode as soon as automation is started.



In manual insertion mode, SampleRail will automatically eject an old sample, so if you want to exchange samples you don't have to eject it first.

Ensure there is no sample left in the eject position of the trolley (marked with an 'E'). Put the sample to insert into the insert position of the trolley (marked with an 'I'). To insert the sample into the NMR magnet push the INSERT button on the front panel. The trolley will move to the NMR magnet, if a sample is in the magnet it will be lifted out of the magnet onto the trolley. The new sample will then be put into the magnet and the trolley will move back to the home position. During the insertion process you will see the following display:

```
*  INSERTING  *  
*            *  
*            *
```

If you have not put a sample into the insert position pressing the INSERT button is just ignored, the trolley will stay in the home position.

If there is a sample left in the eject position of the trolley when you press the INSERT button, the insert process is inhibited and an error message '75 EJECT POSITION NOT EMPTY' is displayed.

```
* ERROR * *  
75 EJECT POSITIO
```

In that case press the CONT button to quit the error message, remove the sample left in the eject position and restart the insert process by pushing the INSERT button.

Ensure there is no sample left in the eject position of the trolley. To eject a sample out of the NMR magnet push the EJECT button on the front panel. The trolley will move to the NMR magnet, the sample will be lifted out of the magnet onto the trolley and the trolley will move back to the home position. During the ejection process you will see the following display:

```
*  EJECTING  *  
*            *  
*            *
```

When the trolley is back in home position you can take the sample out of the trolley.

Operating Instructions

If there is a sample left in the eject position of the trolley when you press the EJECT button, the eject process is inhibited and an error message '75 EJECT POSITION NOT EMPTY' will be displayed.

* ERROR *
75 EJECT POSITIO

In this case press the CONT button to quit the error message, remove the sample left in the eject position and restart the eject process by pushing the EJECT button. The following figure shows the EJECT and INSERT position (with a sample in the insert position).

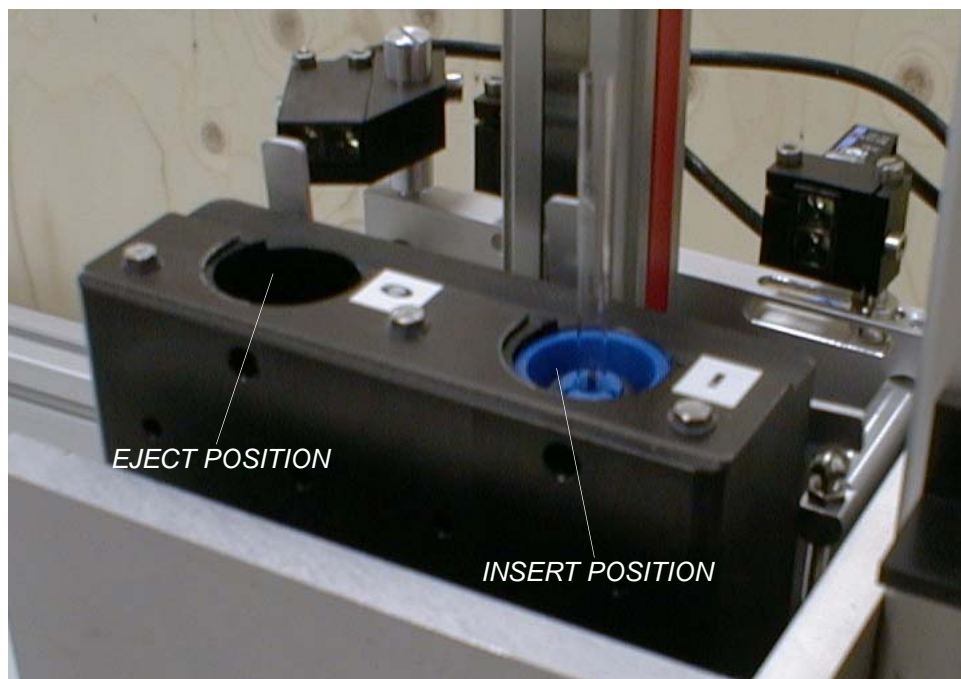

Figure 6.2. Eject and Insert Position in the SampleRail Trolley

The Occurrence of a Failure

6.5

If a failure occurs during operation, the BSR interrupts the current procedure, causing the red „CONT“ LED on the front panel to flash on and off. An error message, consisting of a code number and text, is also displayed. An error signal is then transmitted to the spectrometer host computer.

To resume operation after the error has been corrected, press the „CONT“ button. The BSR will then continue at the same point it had reached just before the failure occurred. The spectrometer host computer will be informed of the successful correction. On rare occasions it may be necessary to do a new initialization, if the above mentioned intervention did not correct the error.

Software Commands

7

Release: BSR20041015_0920

A command always consists of two letters which in some cases are followed by a space and a parameter. The space between the command and the parameter is essential. A command must always be terminated with <CR>. If this syntax is not followed, SampleRail displays the message: "Invalid Parameter" or "Invalid Command".

The syntax of the acknowledge is: [value]<CR><LF>. Value is an alphanumeric string and can have 0 to 32 characters.

SampleRail software commands are divided into two modes:

1. Operation Mode

This is the actual SampleRail operating mode in which complete sample exchange sequences can be run by a host computer.

2. Diagnostic Mode

This mode offers the user a range of commands to test all the different sample changer functions.



The use of Diagnostic Mode requires detailed knowledge about the function of the commands. Only trained service personnel should use Diagnostic Mode for tests, diagnostic or adjustment. Incorrect use of Diagnostic Mode commands may cause damage to the equipment.

The different commands are described in detail in the following sections.

The following list gives a detailed description of all the operation commands in alphabetical order.

Standard Commands

Table 7.1. Standard Commands

Instruction:	CL (Clear Label)
Format:	CL XXX<CR>
Description:	Clear the stored label of the sample in trolley insert position
Reply:	<CR><LF>

Instruction:	CM (Change Mode)
Format:	CM<CR>
Description:	Reports if Fast Change Mode is On or Off
Reply:	CM1<CR><LF> if yes or CM0<CR><LF> if no

Instruction:	CT (Clear Time trigger)
Format:	CT<CR>
Description:	Clear the time trigger for the next sample preparation
Reply:	<CR><LF>

Instruction:	E1 (Eject sequence part 1)
Format:	E1<CR>
Description:	Starts an eject sequence
Reply:	<CR><LF>

Instruction:	E2 (Eject sequence part 2)
Format:	E2<CR>
Description:	Ends an eject sequence.

The trolley will go to the insert position above the magnet or back to the home position depending on whether a new sample is in the insert position of the trolley or not.

Reply:	<CR><LF>
--------	----------

Table 7.1. Standard Commands

Instruction:	FC (Fast Change Mode)
Format:	FC X<CR>
Description:	Sets the status of the sample change mode. X=0 fast change mode is off X=1 fast change mode is on
Reply:	<CR><LF>
<hr/>	
Instruction:	FA (File Available)
Format:	FA<CR>
Description:	Report if an order file for a preparation is available at the preparation robot
Reply:	F1<CR><LF> if yes or F0<CR><LF> if no
<hr/>	
Instruction:	I1 (Insert sequence part 1)
Format:	I1<CR>
Description:	Starts an insert sequence
Reply:	<CR><LF>
<hr/>	
Instruction:	I2 (Insert sequence part 2)
Format:	I2<CR>
Description:	Ends an insert sequence
Reply:	<CR><LF>
<hr/>	
Instruction:	IP (Sample in Insert Position)
Format:	IP<CR>
Description:	Reports if there is a sample is in the insert position of the trolley when the trolley is in home position or in eject position over the magnet (fast change mode).
Reply:	I1<CR><LF> if there is a sample or if the trolley is not in home position. I0<CR><LF> if there is no sample
<hr/>	

Table 7.1. Standard Commands

Instruction:	PD (Probe Down in magnet)
Format:	PD<CR>
Description:	Reports if a sample is down in the magnet
Reply:	P0<CR><LF> if there is no sample P1<CR><LF> if there is a sample
<hr/>	
Instruction:	RL (Report Label)
Format:	RL XXX<CR>
Description:	Reports the label of the sample to be measured.
Reply:	L<number><CR><LF> or L0<CR><LF> if there is no label available
<hr/>	
Instruction:	RP (Report measurement Position)
Format:	RP<CR>
Description:	reports the current measurement position (command only for BACS compatibility)
Reply:	P<number><CR><LF> or P0<CR><LF> if there is no sample in the magnet
<hr/>	
Instruction:	RT (Report Tube ID)
Format:	RT<CR>
Description:	Reports the label of the actual measured sample in magnet.
Reply:	L<number><CR><LF> or L0<CR><LF> if there is no sample in the magnet
<hr/>	
Instruction:	SD (move Sample Down)
Format:	SD<CR>
Description:	If a sample is detected in the magnet after the insert sequence, trolley moves back to home position (only used without fast change mode).
Reply:	<CR><LF>
<hr/>	

Table 7.1. Standard Commands

Instruction:	SE (SEcurity test)
Format:	ST<CR>
Description:	Tests if a sample is left in the magnet.
Reply:	S0<CR><LF> if there was no sample in the magnet. S1<CR><LF> if there was a sample in the magnet.
Instruction:	SL (Short pulse on Lift)
Format:	SL<CR>
Description:	Gives a short air pulse on the sample lift to free a hanging sample.
Reply:	<CR><LF>
Instruction:	ST (Shim sensor Test)
Format:	ST<CR>
Description:	Tests if a sample is detected in the trolley above shim tube.
Reply:	S0<CR><LF> if there is no sample S1<CR><LF> if there is a sample
Instruction:	TD (Keys Disabled)
Format:	TD<CR>
Description:	locks the front panel keys
Reply:	<CR><LF>
Instruction:	TE (Keys Enabled)
Format:	TE<CR>
Description:	unlocks the front panel keys
Reply:	<CR><LF>
Instruction:	TT (Time Trigger)
Format:	TT<CR> or TT XXX<CR>
Description:	Trigger for next sample preparation (if a time argument XXX in seconds is sent the next sample preparation will be triggered in XXX seconds) if fast change mode on the trolley moves back to home position.
Reply:	<CR><LF>

Table 7.1. Standard Commands

Instruction:	VB (Version Build)
Format:	VB<CR>
Description:	Reports the actual firmware version inclusive the time of compilation and an identification short string.
Reply:	BSRyyyymmdd_hhmm<CR><LF>
<hr/>	
Instruction:	VM (Version Millennium)
Format:	VM<CR>
Description:	Reports the actual firmware version in Y2K compatible format.
Reply:	yyyymmdd<CR><LF>
<hr/>	
Instruction:	VS (VerSion)
Format:	VS<CR>
Description:	Reports the actual firmware version.
Reply:	yymmdd<CR><LF>
<hr/>	
Instruction:	ZY (Zero Yell)
Format:	ZY<CR>
Description:	Repeats the last sent reply
Reply:	Last reply<CR><LF>
<hr/>	
Instruction:	ESC. (ESCape key + ".")
Format:	ESC.<CR>
Description:	Switch to the Diagnostic mode.
Reply:	SAMPLECHANGER DIAGNOSTIC MODE!<CR><LF>

Table 7.2. Standard Commands for BACS Compatibility

The following commands are only for BACS compatibility, they have no effect on SampleRail:

Instruction: **AP**(AutoPrep **P**resent)

Format: AP<CR>

Description: Checks if AutoPrep is present.

Reply: BD0<CR><LF>

Instruction: **BD** (**B**arcode **D**igits)

Format: BD XX<CR>

Description: Set barcode length to 4, 6, 12 or 20 digits

Reply: <CR><LF>

Instruction: **BS** (Report **B**arcode **S**etting)

Format: BS<CR>

Description: Report setting of barcode length

Reply: BDXX<CR><LF>

Instruction: **CP** (Report **P**osition)

Format: CP<CR>

Description: Sends the current magazine position.

Reply: P<number><CR><LF>

Instruction: **LS** (Sample **L**ift **S**tatus)

Format: LS<CR>

Description: Reports the actual status of the sample lift control

Reply: NL0<CR><LF> if the lift is controlled by SampleRail
NL1<CR><LF> if the lift is controlled by BSMS.

Table 7.2. Standard Commands for BACS Compatibility

Instruction:	MS (Number of M easured s amples)
Format:	MS<CR>
Description:	Reports the number of measured samples.
Reply:	MS0<CR><LF>
<hr/>	
Instruction:	NL (N o L ift)
Format:	NL X<CR>
Description:	Sets the status of the sample lift control X=0 lift is controlled by SampleRail X=1 lift is controlled by BSMS
Reply:	<CR><LF>
<hr/>	
Instruction:	NM (N umber of available M agazine positions)
Format:	NM<CR>
Description:	Reports the number of available magazine positions.
Reply:	N192<CR><LF> N384<CR><LF> (BSR VAC)
<hr/>	
Instruction:	RC (R estore C ontrol)
Format:	RC X<CR>
Description:	Sets the restore mode of samples.
Reply:	<CR><LF>
<hr/>	
Instruction:	RS (R eport S etting of restore mode)
Format:	RS<CR>
Description:	Reports the restore mode of samples.
Reply:	RCX<CR><LF>
<hr/>	
Instruction:	SB (S ample in B arcode reader position)
Format:	SB<CR>
Description:	Reports if a sample is in the barcode reader position.
Reply:	S0<CR><LF> if there is no sample S1<CR><LF> if there is a sample

Table 7.2. Standard Commands for BACS Compatibility

Instruction: **SC (Screen mode)**
 Format: SC X<CR>
 Description: Sets the specific display mode (command only for BACS compatibility, dummy for SampleRail).
 Reply: <CR><LF>

Instruction: **SP (Sample present in position)**
 Format: SP<CR>
 Description: For SampleRail test if a sample is present in the insert position of the trolley at the home position.
 Reply: S0<CR><LF> if there is no sample
 S1<CR><LF> if there is a sample

Instruction: **SS (Screen Status)**
 Format: SS<CR>
 Description: Reports the actual display mode.
 Reply: SCX<CR><LF>

Error Mode**7.3**

In this mode the following two commands will be accepted:

Table 7.3. Error Mode Commands

Instruction: **CO (Continue)**
 Format: CO<CR>
 Description: Continues the program at the point where it was interrupted when the error showed up.
 Reply: <CR><LF>

Instruction: **HO (Home)**
 Format: HO<CR>
 Description: SampleRail moves to its "HOME" position at the preparation robot.
 Reply: <CR><LF>

In diagnostic mode all operation mode commands are accepted. The message "EXECUTED!" is send before the <CR><LF> when a command is finished.

The additional commands of the diagnostic mode are listed below.

Table 7.4. Diagnostic Mode Commands

Instruction:	AB (Adjust B arcode reader)
Format:	AB<CR>
Description:	Sets the barcode reader into continuous read mode for mechanical adjustment.
Reply:	EXECUTED!<CR><LF>
Instruction:	AE (A ctivate E ndstop)
Format:	AE<CR>
Description:	Activates the end stop cylinder above the magnet.
Reply:	EXECUTED!<CR><LF>
Instruction:	CE (C rossing to E ject)
Format:	CE<CR>
Description:	Moves from the XY-crossing to the eject position above the magnet.
Reply:	EXECUTED!<CR><LF>
Instruction:	CG (C lose G ripper)
Format:	CG<CR>
Description:	Closes the sample gripper above magnet.
Reply:	EXECUTED!<CR>
Instruction:	CI (C rossing to I nsert)
Format:	CI<CR>
Description:	Moves from the XY-crossing to the insert position above the magnet.
Reply:	EXECUTED!<CR><LF>

Table 7.4. Diagnostic Mode Commands

Instruction:	DE (Deactivate Endstop)
Format:	DE<CR>
Description:	Deactivates the end stop cylinder above the magnet.
Reply:	EXECUTED!<CR><LF>
<hr/>	
Instruction:	DS (Display Sensors)
Format:	DS<CR>
Description:	Displays the actual values of all sensors.
	S1:
	1 carriage on tecan (S1,X1)
	2 trolley on tecan (S1,X5)
	3 sample in insert position (S1,X6)
	4 sample in insert position (S1,X4)
	S2:
	1 vertical carriage on crossing (S2,X1)
	2 horizontal carriage on crossing (S2,X2)
	3 suction tube on position (only BSR VAC con. S2,X6)
	4 suction tube off position (only BSR VAC con. S2,X4)
	5 ABW detect (con. S2,X5)
	S3:
	1 endstop cylinder on eject position (S3,X2)
	2 endstop cylinder on insert position (S3,X3)
	3 carriage at shim (insert or eject position con. S3,X4)
	4 trolley at shim (eject position con. S3,X5)
	5 gripper is open (light barrier sensor con. S3,X6)
	6 gripper cylinder is active (micro-switch con. S3,X7)
	7 sample over magnet (fiber-optic sensor con. S3,X11)
	8 sample down in magnet (sample down unit con. S3,X12)
	S4:
	1 hood at shim (S1,X3) not on BSR VAC
	2 hood at tecan (S3,X8) not on BSR VAC
	3 pressure (switch in pneumatic unit)
Reply:	S1:xxxx S2:xxxxx S3:xxxxxxx S4:xxx<CR><LF>
<hr/>	
Instruction:	DT (Display Test)
Format:	DT<CR>
Description:	Calls the display test program with the character pattern check routine. Pressing the CONT button stops the test.
Reply:	EXECUTED!<CR><LF>
<hr/>	

Table 7.4. *Diagnostic Mode Commands*

Instruction: **DV (Display Valves)**
 Format: DV<CR>
 Description: Displays the actual values of all valves:
 1 bolt cylinder at XY-crossing
 2 gripper cylinder above magnet
 3 endstop cylinder above magnet
 4 horizontal cylinder to XY-crossing
 5 horizontal cylinder to magnet
 6 vertical cylinder downwards
 7 vertical cylinder upwards
 8 sample lift
 9 spare valve (BSR VAC position suction tube)

Reply: V1:xxxxxxxx<CR><LF>

Instruction: **EC (Eject to Crossing)**
 Format: EC<CR>
 Description: Moves from the eject position above magnet to the XY crossing

Reply: EXECUTED!<CR><LF>

Instruction: **EI (Eject to Insert)**
 Format: EI<CR>
 Description: Moves from the eject position above magnet to the insert position above the magnet

Reply: EXECUTED!<CR><LF>

Instruction: **IC (Insert to Crossing)**
 Format: IC<CR>
 Description: Moves from the insert position above magnet to the XY-crossing

Reply: EXECUTED!<CR><LF>

Instruction: **IE (Insert to Eject)**
 Format: IE<CR>
 Description: Moves from the insert position above magnet to the eject position above the magnet

Reply: EXECUTED!<CR><LF>

Table 7.4. Diagnostic Mode Commands

Instruction:	IH (Ignore Hood sensors)
Format:	IHX<CR>
Description:	Moves even with opened doors (for BSR only). X=1 Ignore hood sensors, X=0 not ignore hood sensors
Reply:	EXECUTED!<CR><LF>

Instruction:	LA (Loop All)
Format:	LA<CR>
Description:	Starts the continuous test loop program. First a home seek will be started. You must put two samples into the eject and the insert position of the trolley. After that the two samples are continuously exchanged and the number of loops will be displayed. To stop the test loop program press the RESET button.
Reply:	1 Loop(s)<CR><LF> 2 Loop(s)<CR><LF> 3 Loop(s)<CR><LF> . .

Instruction:	LD (Lift Down)
Format:	LD<CR>
Description:	Switches the sample lift off
Reply:	EXECUTED!<CR><LF>

Instruction:	LH (Loop Horizontal)
Format:	LH<CR>
Description:	This command starts a loop program to test horizontal unit. Stop the endless loop by pressing the RESET button.
Reply:	EXECUTED!<CR><LF>

Table 7.4. *Diagnostic Mode Commands*

Instruction:	LL (Lift Loop)
Format:	LL<CR>
Description:	Starts the continuous lift loop program. First a home seek will be started. You must put a samples into the eject or the insert position of the trolley. The trolley drives with the position over the magnet, in which the sample is. After that the sample are continuously inserted and ejected. The number of loops will be displayed. To stop the test loop program press the RESET button.
Reply:	1 Loop(s)<CR><LF> 2 Loop(s)<CR><LF> 3 Loop(s)<CR><LF> . .
<hr/>	
Instruction:	LU (Lift Up)
Format:	LU<CR>
Description:	Switches the sample lift on
Reply:	EXECUTED!<CR><LF>
<hr/>	
Instruction:	LV (Loop Vertical)
Format:	LV<CR>
Description:	This command starts a loop program to test vertical unit. Stop the endless loop by pressing the RESET button.
Reply:	EXECUTED!<CR><LF>
<hr/>	
Instruction:	MP (Send MP command to robot)
Format:	MP<CR>
Description:	Sends a 'MP' command (Measured Probe) to the preparation robot
Reply:	EXECUTED!<CR><LF>
<hr/>	

Table 7.4. Diagnostic Mode Commands

Instruction:	NP (Send NP command to robot)
Format:	NP<CR>
Description:	Sends a 'NP' command (Next Preparation) to the preparation robot.
Reply:	EXECUTED!<CR><LF>
<hr/>	
Instruction:	OA (Send OA command to robot)
Format:	OA<CR>
Description:	Sends a 'OA' command (Order file Available) to the preparation robot.
Reply:	EXECUTED!<CR>
<hr/>	
Instruction:	OG (Open Gripper)
Format:	OG<CR>
Description:	Opens the sample gripper above magnet
Reply:	EXECUTED!<CR>
<hr/>	
Instruction:	RV (Reset Valve)
Format:	RVx<CR>
Description:	Resets a specific valve: x=0 bolt cylinder at XY-crossing x=1 gripper cylinder above magnet x=2 endstop cylinder above magnet x=3 horizontal cylinder to XY-crossing x=4 horizontal cylinder to magnet x=5 vertical cylinder downwards x=6 vertical cylinder upwards x=7 sample lift x=8 spare valve (BSR VAC position suction tube)
Reply:	EXECUTED!<CR>
<hr/>	
Instruction:	SF (Suction tube in off position)
Format:	SF<CR>
Description:	Moves the suction tube to the OFF position (only BSR VAC).
Reply:	EXECUTED!<CR><LF>
<hr/>	

Table 7.4. Diagnostic Mode Commands

Instruction: **SI** (Send **SI** command to robot)
 Format: SI<CR>
 Description: Sends a 'SI' command (Sample ID) to the preparation robot
 Reply: EXECUTED!<CR>

Instruction: **SN** (Suction tube in **oN** position)
 Format: SN<CR>
 Description: Moves the suction tube to the ON position (only BSR VAC).
 Reply: EXECUTED!<CR><LF>

Instruction: **SV** (Set Valve)
 Format: SVx<CR>
 Description: Sets a specific valve:
 x=0 bolt cylinder at XY-crossing
 x=1 gripper cylinder above magnet
 x=2 endstop cylinder above magnet
 x=3 horizontal cylinder to XY-crossing
 x=4 horizontal cylinder to magnet
 x=5 vertical cylinder downwards
 x=6 vertical cylinder upwards
 x=7 sample lift
 x=8 spare valve (BSR VAC position suction tube)
 Reply: EXECUTED!<CR>

Instruction: **VD**(Vertical **D**own)
 Format: VD<CR>
 Description: Moves vertically downward
 Reply: EXECUTED!<CR><LF>

Instruction: **VU**(Vertical **U**p)
 Format: VD<CR>
 Description: Moves vertically upward
 Reply: EXECUTED!<CR><LF>

Table 7.4. Diagnostic Mode Commands

Instruction:	TH (Test Hood sensors)
Format:	TH<CR>
Description:	Tests whether all hoods are closed (for BSR only)
Reply:	EXECUTED!<CR><LF> or hood error
<hr/>	
Instruction:	ESC? (ESCape key + "?")
Format:	<ESC>?<CR>
Description:	Switches to operation mode.
Reply:	SAMPLECHANGER OPERATION MODE! <CR><LF>
<hr/>	

Communication with the Tecan Robot

8

Introduction

8.1

SampleRail™ works together with a TECAN pipetting robot as a preparation system. The communication between the SampleRail control unit and the TECAN controlling PC is via an RS232 link and uses the same protocol as the communication between SampleRail and the spectrometer host computer.

A command always consists of two letters and is always terminated with <CR>. The response for any command is terminated with <CR><LF>. Sometimes only <CR><LF> is sent.

Commands

8.2

The following alphabetical list provides a detailed description of all commands.

Table 8.1. *Commands for TECAN Robot*

Sender:	TECAN
Receiver:	SampleRail controller
Instruction:	ES (Eject Sample)
Format:	ES<CR>
Description:	TECAN wants to take a sample out of the eject position of the SampleRail trolley. SampleRail is locked for motion.
Reply:	<CR><LF>

Communication with the Tecan Robot

Sender: TECAN
Receiver: SampleRail controller
Instruction: **IS (Insert Sample)**
Format: IS<CR>
Description: TECAN wants to put a sample into the insert position of the SampleRail trolley. SampleRail is locked for motion.
Reply: <CR><LF>

Sender: SampleRail controller
Receiver: TECAN
Instruction: **MP (Measured Probe)**
Format: MP<CR>
Description: SampleRail announces that a measured sample is to be removed from the trolley
Reply: <CR><LF>

Sender: SampleRail controller
Receiver: TECAN
Instruction: **NP (Next Preparation)**
Format: NPCR>
Description: SampleRail triggers the next sample preparation
Reply: <CR><LF>

Sender: SampleRail controller
 Receiver: TECAN
 Instruction: **OA (Order File Available)**
 Format: OA<CR>
 Description: SampleRail asks if order files for more preparations are available at the TECAN.
 Reply: OA0<CR><LF> if no more order files are available
 OA1<CR><LF> if one or more order files are available

Sender: SampleRail controller
 Receiver: TECAN
 Instruction: **SI (Sample Identification)**
 Format: SI<CR>
 Description: SampleRail asks for the label of the sample already placed into the trolley
 Reply: SIxxxxxxx<CR><LF>

Sender: TECAN
 Receiver: SampleRail controller
 Instruction: **TR (Tecan Ready)**
 Format: TR<CR>
 Description: TECAN unlocks SampleRail after ejecting or inserting a sample
 Reply: <CR><LF>

Error Handling

9

Introduction

9.1

During operation two kinds of error messages may occur:

- Errors requiring user intervention.
- Errors concerning communication between SampleRail and the host computer.

These two kinds of failures are treated differently, and are explained in detail in the following sections.

Error Messages

9.2

An error message consists of two parts:

- A two-digit error code.
- An explicit error message.

A DEL character (decimal 127) will precede any error message transmitted via the SIO channel. In manual insertion mode the error message will not be sent to the host computer via RS232 link.

Errors Requiring User Intervention

9.2.1

A full list of error numbers and messages with comments are listed in the following table. The messages will be displayed and transmitted through the SIO channel.

Table 9.1. Errors requiring user intervention

Error Code	Error Message	Description	Occurrence
02	DOWNWARD MOTION FAILED	The slider at the vertical unit did not reach the lower position at the preparation robot within a defined time.	D
03	UPWARD MOTION FAILED	The slider at the vertical unit did not reach the upper position at the XY-crossing within a defined time.	D

Error Handling

Table 9.1. Errors requiring user intervention

Error Code	Error Message	Description	Occurrence
11	SAMPLE DETECT OVER MAGNET FAILED	The sample did not reach the eject position of the trolley during an start eject sequence (E1).	O
12	INITIALIZATION INSUFFICIENT	The initialization could not be accomplished successfully. The error message is indicated only at the LCD display.	D, O, M
13	SAMPLE DETECT IN MAGNET FAILED	The sample did not reach the position down in the shim system during an end insert sequence (I2).	O
14	SAMPLE GRASPING FAILED	The sample was not grasped in the trolley over the shim during an eject sequence or after a failed insert.	D, O, M
15	NO SAMPLE IN INSERT POS. DETECTED	The sample was not detected after an insert from the Tecan robot	O
23	SAMPLE MISSING	The sample did not reach a position in the trolley or down in the shim system during an insert or eject sequence.	O, M
26	INSERT POSITION NOT EMPTY	A sample in the insert position was detected.	O
53	FAILED TO ACTIVATE SUCTION TUBE	The suction position was not reached (only BSR VAC).	D, O, M
54	FAILED TO DEACTIVATE SUCTION TUBE	The suction off position was not reached (only BSR VAC).	D, O, M
55	SAMPLE DETECT IN MAGNET	A sample in the shim system was detected.	D, O
56	COMMAND ARE NOT AVAILABLE!	Command in this constellation is not permitted.	D, O
60	HORIZONTAL MOTION TO INSERT POS. FAILED	The slider at the horizontal unit did not reach the insert position above the magnet within a defined time.	D, M
61	HORIZONTAL MOTION TO EJECT POS. FAILED	The slider at the horizontal unit did not reach the eject position above the magnet a defined time.	D, M
62	HORIZONTAL MOTION TO CROSSING FAILED	The slider at the horizontal unit did not reach the XY-crossing within a defined time.	D
63	FAILED TO ACTIVATE ENDSTOP EJECT POS.	The endstop above the magnet did not move to the eject position.	D
65	FAILED TO OPEN GRAB	The gripper in the trolley above the magnet did not open.	D, O
66	FAILED TO CLOSE GRAB	The gripper in the trolley above the magnet did not close.	D, O

Table 9.1. Errors requiring user intervention

Error Code	Error Message	Description	Occurrence
67	FAILED TO MOVE TO HOME POS.	Search of the home position failed.	D, M
68	MOTION TO EJECT POSITION FAILED	The trolley did not reach the eject position above the magnet within a defined time.	O
69	MOTION TO INSERT POSITION FAILED	The trolley did not reach the insert position above the magnet within a defined time.	O
70	MOTION TO ROBOT STATION FAILED	The trolley did not reach the preparation robot within a defined time.	O, M
71	ENDLESS LOOP FAILED	The endless test loop stopped when a motion failure or a missing sample occurred.	D
72	HOOD AT ROBOT OPENED	The hood at the transfer unit SampleRail / robot is open. For safety purposes all further motion is prevented. When the hood is closed, press 'continue'.	O
73	HOOD AT MAGNET OPENED	The hood at the transfer unit SampleRail / magnet is open. For safety purposes all further motion is prevented. When the hood is closed, press 'continue'.	O
74	SAMPLE RAIL LOCKED BY TECAN	The trolley cannot move because the preparation robot locks the motion while inserting a sample into or ejecting a sample out of the trolley.	O
75	EJECT POSITION NOT EMPTY	In Diagnostic and Operation Mode: a sample is detected in the eject position above the magnet during an eject sequence. In Manual Insertion mode: a sample is detected in the eject position at the preparation robot when the EJECT or the INSERT button was pressed. The error message is not sent to the host computer via RS232 link.	D, O, M
76	TECAN ROBOT NOT RESPONDING	The TECAN preparation robot did not answer a command within a defined time.	D, O
78	ERROR IN TECAN COMMUNICATION	The answer string of the TECAN preparation robot was corrupt.	D, O

Occurrence: D = Diagnostic Mode
O = Operation Mode
M = Manual Insertion Mode

In the test routines 'Loop All' and 'Lift Loop' special error messages are sent when errors occur. The error numbers begin with "L". A description of the error follows the error number.

Error Handling

If one of the above mentioned failures is observed, the program branches off into an error correction routine. It can be restarted by pressing the CONT button or by entering the command „CO” via the RS 232C link. As an alternative the command „HO” can be used to move the SampleRail into its „HOME” position. If a failure cannot be corrected in this manner you will have to restart the whole automation system (SampleRail, the preparation robot’s control software, and the spectrometer automation software).



If the system still hangs or runs into the same error state after a complete automation restart, consult the operating instructions, or contact a BRUKER service representative.

Communication Errors

9.2.2

Failures in the communication between the SampleRail and the host computer may occur if an incorrect command is given by the host computer, or if unconnected hardware is addressed. Following such an error message, SampleRail will accept a new command and not enter error mode. In this case, error messages are not displayed, but are sent back to the host computer. If any of these errors occur consult your operating instructions, or contact a BRUKER service representative.

Table 9.2. Errors in the Communication Between SampleRail and Host Computer

Error Code	Error Message	Description	Occurrence
51	INVALID COMMAND	The received command was invalid.	O
52	INVALID PARAMETER	The command contained an invalid or incorrect parameter.	O
59	BUSY	The command cannot be executed as a concurrent sequence of commands is not yet finished.	O

Occurrence: D = Diagnostic Mode
O = Operation Mode
M = Manual Insertion Mode

Operator Maintenance

10

Introduction

10.1

SampleRail™ requires only a few operator maintenance steps.



Carry out maintenance work only with the SampleRail switched off and the compressed air system depressurized. Failure to do this may result in body parts being crushed.

If the horizontal or vertical unit's pneumatic linear drive leaks, moves slowly, or is jerky maintenance work is necessary. This work can only be done by trained service personnel according to the operating instructions from the cylinder manufacturer.

Cleaning

10.2

If you find attrition on the horizontal or vertical unit rails, clean them with a dry, lint free rag. *Do not use cleaning solvents.* After cleaning the rails, it is recommended that you grease the sliding surface of the pneumatic linear drive (see "**Greasing the Pneumatic Linear Drives**" on page 78).

For cleaning the hoods/enclosures you can use any non-aggressive cleaning liquid (e.g. dishwasher liquid).

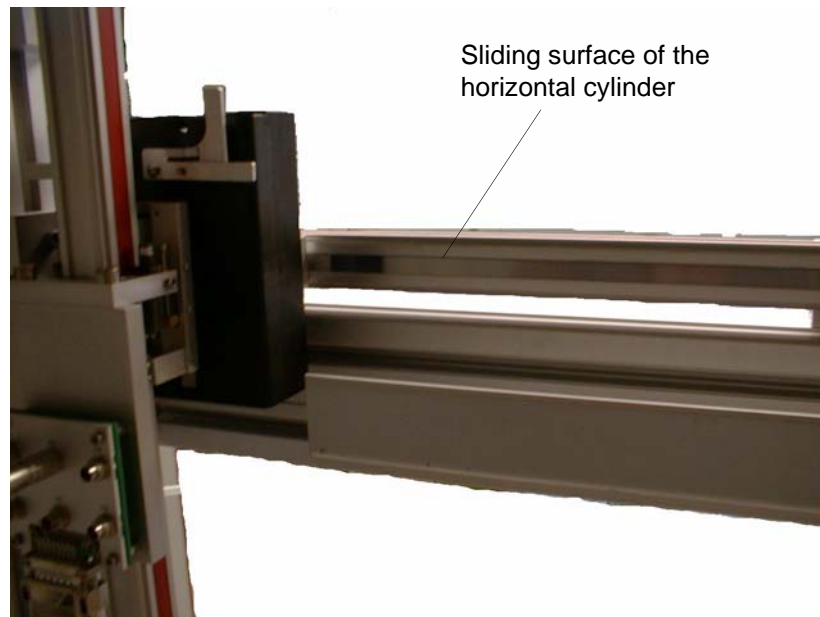

Figure 10.1. Horizontal Cylinder

The sliding surface of the horizontal and the vertical units pneumatic linear drives should be greased annually. Use slow speed grease for pneumatic cylinders (P/N 68482) which you will find in the tool chest in the standard accessories delivered with your SampleRail.

First clean the sliding surface with a dry, lint-free rag. Then apply a thin film of grease onto the surface of the entire length of the pneumatic linear drives.

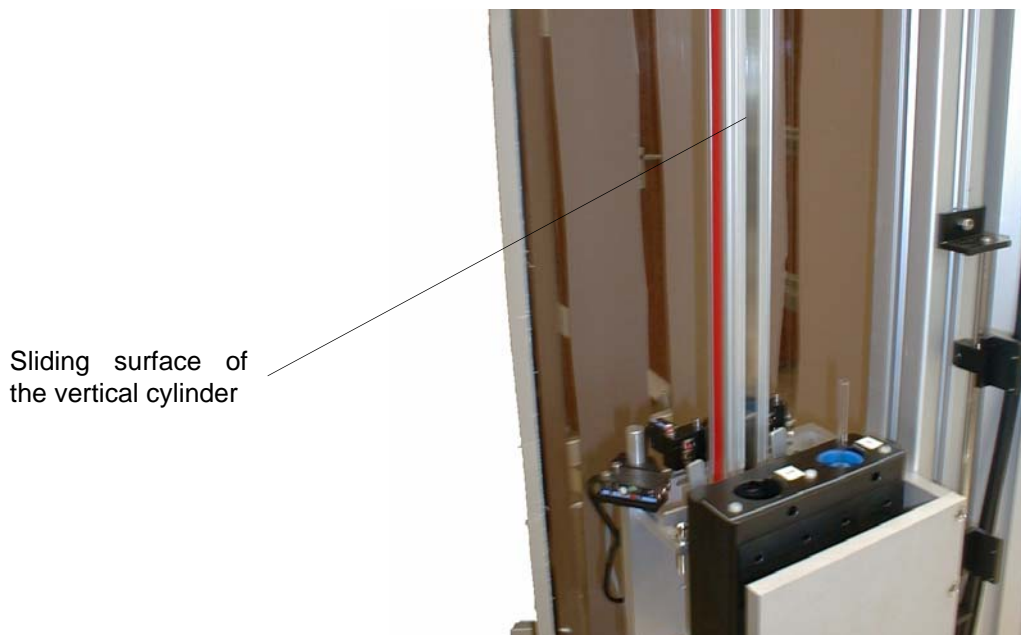

Figure 10.2. Vertical Cylinder

Cleaning After an NMR-Tube Breaks

10.4



When an NMR tube breaks it should be cleaned up immediately to prevent injury from glass pieces and/or harmful liquids. Cleaning should be done with the upmost caution, particularly when hazardous liquids are used. For more information read the safety instructions "Hazards from Samples, Breakage of Glass... and Other Substances" on page 15.

- After a tube breaks, immediately clean the glass parts and liquids from SampleRail (e.g. with small vacuum cleaner) and remove the hose to the magnet.
- Clean the parts with water or a mild cleaning solvent.
- The shim upper part and probe should be inspected, cleaned and repaired by authorized personnel only.
- SampleRail should only be returned to use if the parts mentioned above are in perfect condition.

Only for the BSR VAC: Removal of glass fragments out of the shim upper part is possible using the spiral provided in the accessories kit.

Pivoting the SampleRail Horizontal Arm

10.5

For servicing it may be necessary to pull the horizontal arm away from its normal position. For this reason the vertical and horizontal pivoting arrangement have been built with two joint components.



Figure 10.3. Horizontal Arm Joint Components

Operator Maintenance

Since each SampleRail installation is customer specific (ceiling and wall mountings and fixtures), the operational procedure for pivoting may differ.

Versions without joint components can only be rotated by moving the TECAN table.

Be careful not to tilt the construction when working with the fastening.



Before any maintenance: Switch off the electrical power supply on the back of the BSR Control Unit and unplug the power cord.

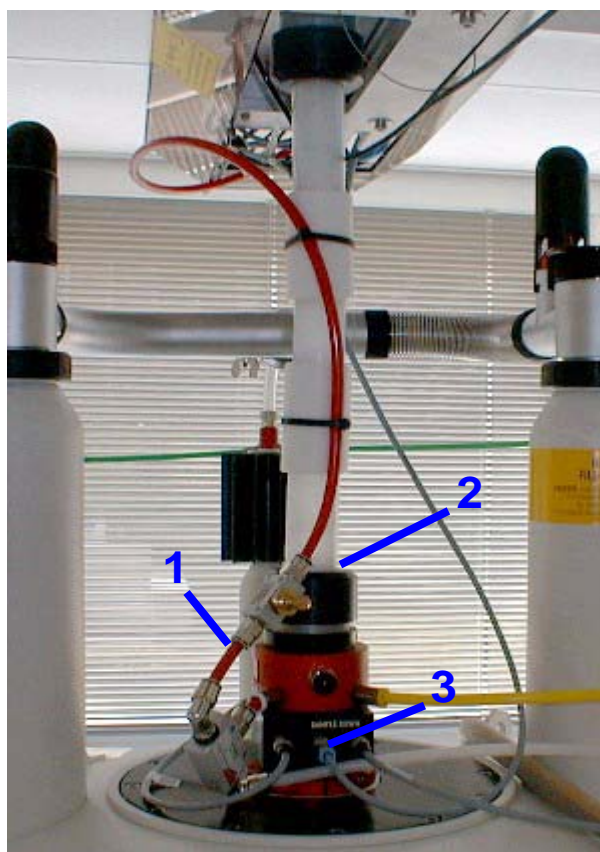

1. Disconnect the compressed air hose from the lift air valve.
2. Detach the transport tube from the shim upper part.
3. Disconnect the BSR connector from the Sample Down Unit.

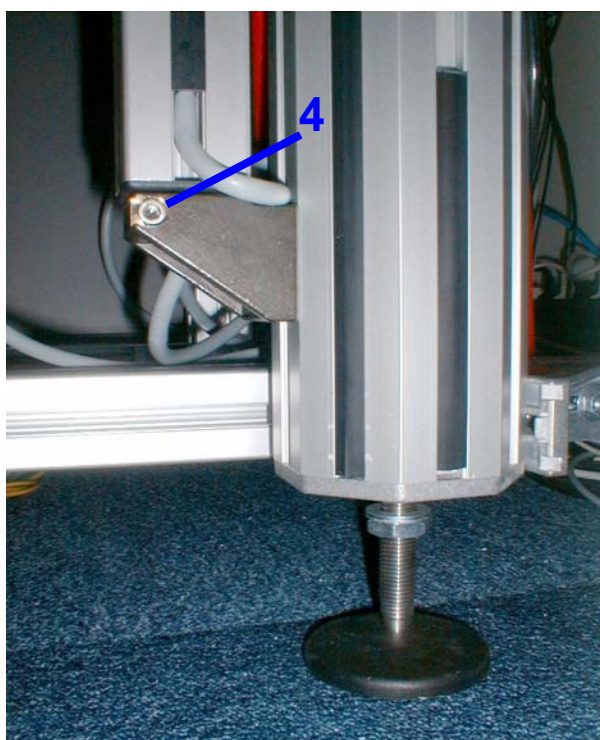

4. Disconnect the fixation screw from the lower joint component.

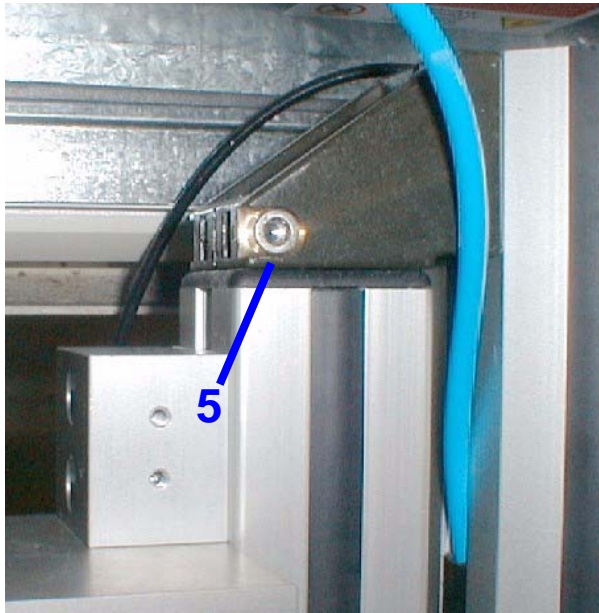

5. Disconnect the fixation screw from the upper joint component.

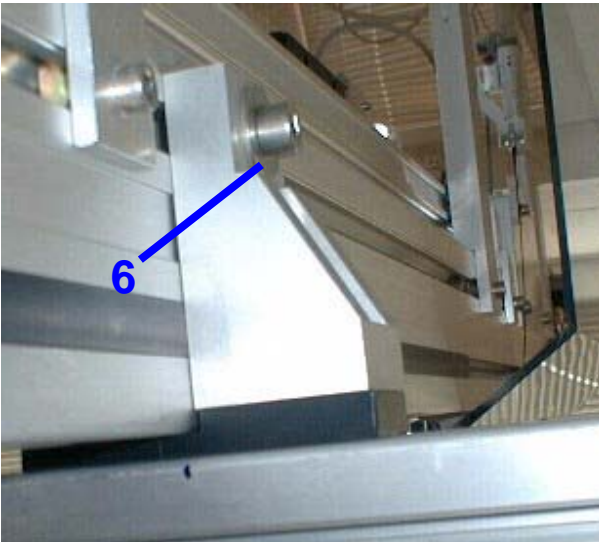

6. Unscrew the upper screw of the connecting piece between the horizontal arm and the suspension.

Do not completely unscrew the connecting piece from the suspension. This will allow simpler reassembly in the same position.

Raise the horizontal arm slowly and push it sideways away from the connecting piece.

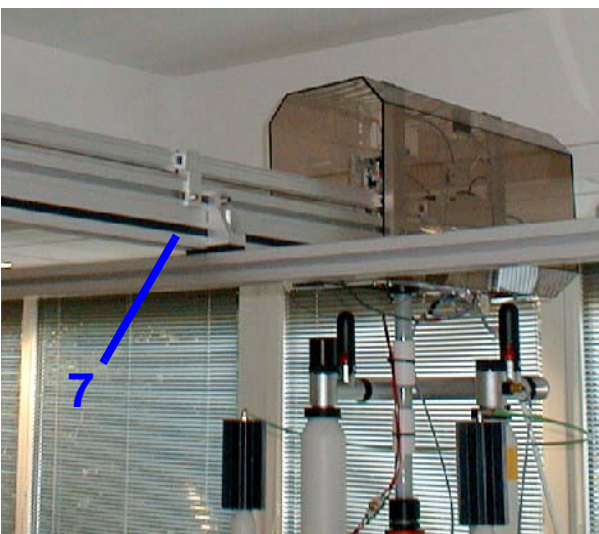

7. The BSR can now be turned. The direction of rotation depends on the construction of BSR. When rotating the BSR make certain that no cables or hoses are damaged.

8. To return the BSR to its operating position, repeat the steps in reverse order. Afterwards, control all the connections to ensure they are tight.

Figure 10.4. Workflow for Rotating the BSR

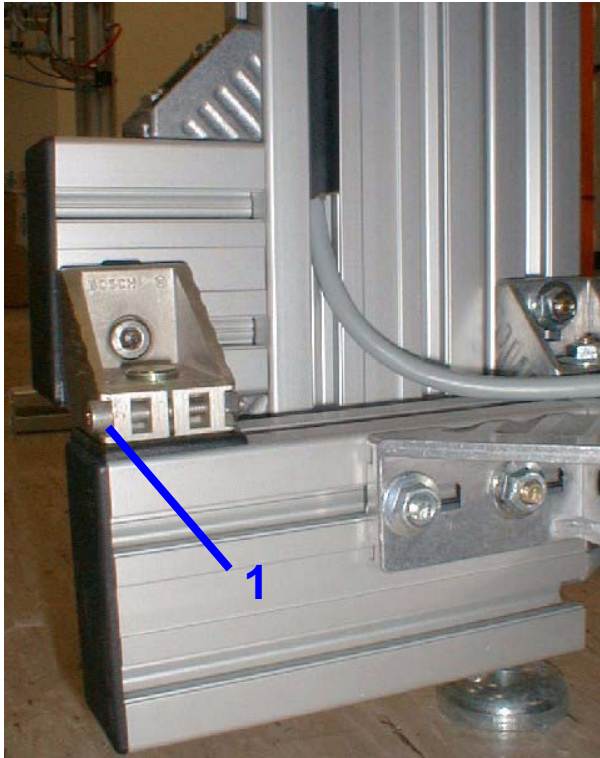

1. Loosen the lock screw at the lower joint component.

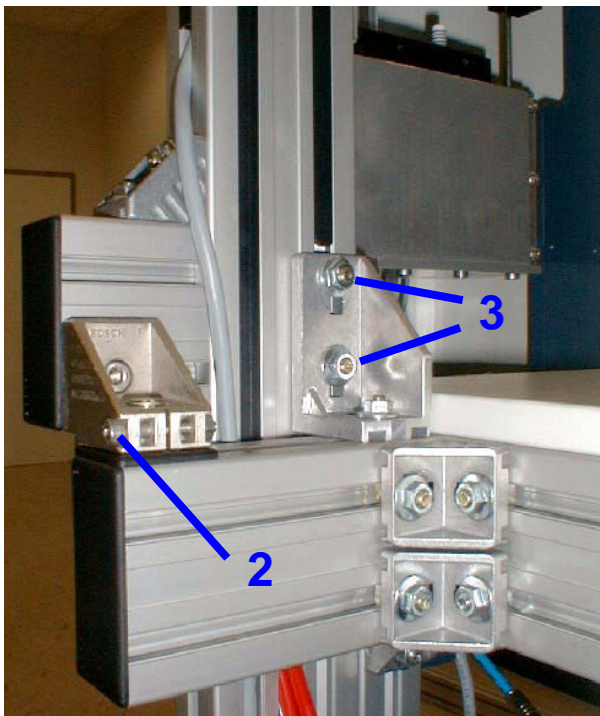

2. Loosen the lock screw at the upper joint component.
3. Loosen and remove the bolts from the attachment bracket.

Figure 10.5. Workflow for Rotating the BSR VAC



4. Take off the lead from the 2D barcode scanner. The fastening for the RJ45 plug can be opened with a small screwdriver.

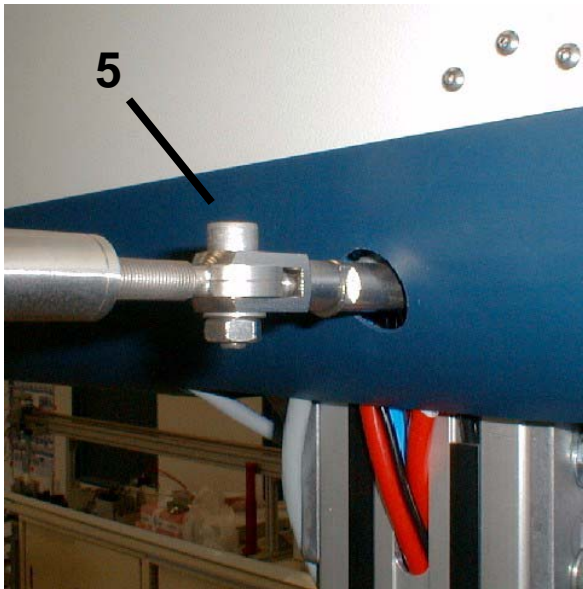

5. Loosen and remove the bolt holding the bracing over the Tecan robot.

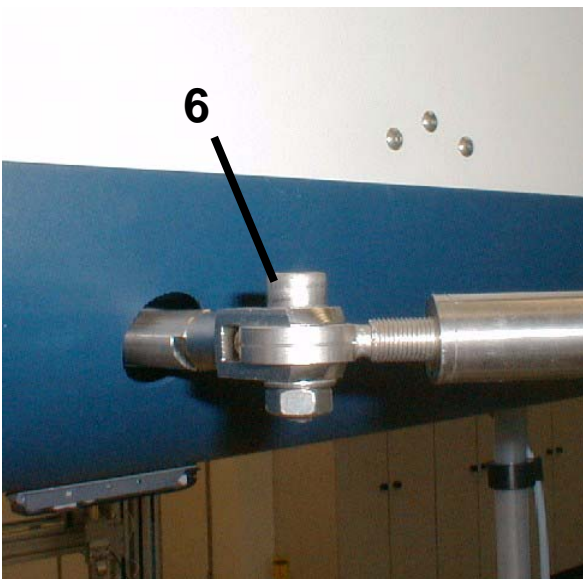

6. Loosen and remove the bolt holding the bracing over the Tecan robot.

The BSR VAC can now be rotated. The direction of rotation depends on the construction of the BSR VAC. When rotating the BSR VAC make certain that no cables or hoses are damaged.

To return the BSR VAC to its operating position, repeat the steps in reverse order. Afterwards, control all the connections to ensure they are tight.

Opening the BSR Cover

10.7

The protective hoods / enclosures must not be opened when SampleRail is in operation (see **"Important Safety Considerations" on page 13**).

Removing the BSR Covers

10.7.1

Vertical Hood

The vertical hood is secured using a spring-actuated lock and, beginning in 2005, with an additional screw at the front which helps prevent unintentional opening. To open the hood this screw must be unscrewed.

Transfer Station Protection Hood

The transfer station protection hood over the magnet can be removed by lifting it upwards.

Both hoods contain micro-switches which prevent movement from being initiated when the hood is open (beginning with firmware version: BSR_V20041015 an error message will be displayed). A movement in progress is not interrupted when the hood is opened.



Figure 10.6. The Vertical Hood

The protective enclosure for the BSR VAC consists of a vertical cover with a spring-actuated lock, and a horizontal cover which is secured with screws.

The vertical cover must be removed before the horizontal cover can be opened.



1. Loosen the screw on the vertical cover which prevents unintentional opening.

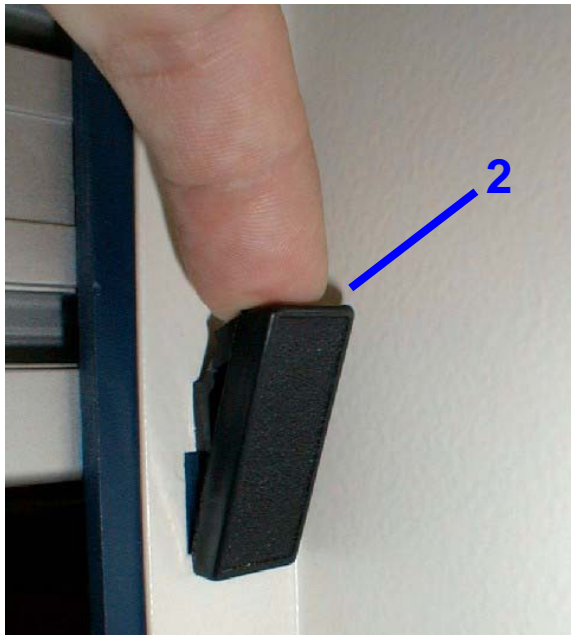

2. Open the 6 catches at the front of the cover and remove the cover.

Figure 10.7. Removing the Vertical Covering

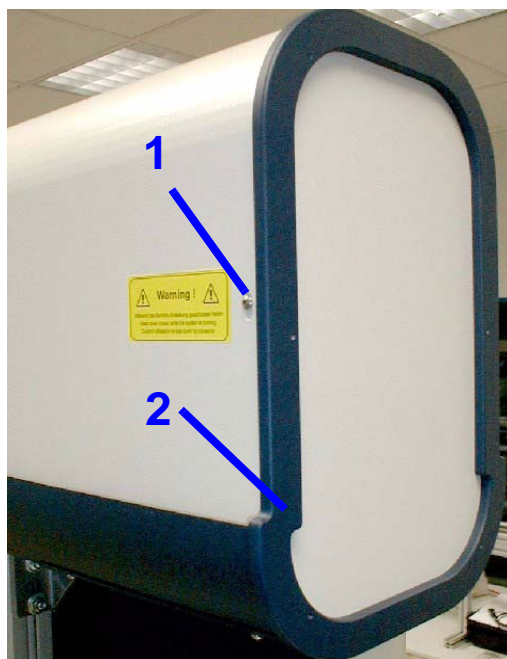

1. The horizontal cover is also secured with two screws (left and right) which prevent unintentional opening. Loosen these screws.



2. Remove the cover plate.

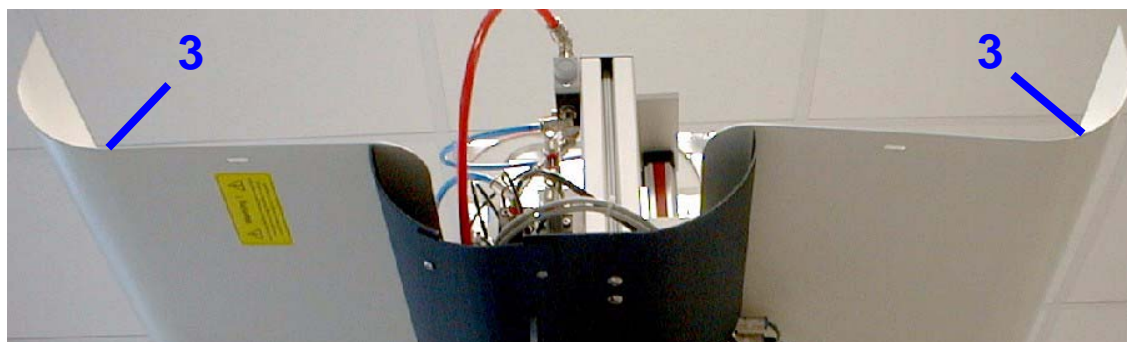

3. The upper cover enclosures can then be opened (unfolded).

Figure 10.8. Removing the Horizontal Covering

Barcode Reader Option

11

Introduction

11.1



For the safe identification of the NMR samples (allocation to preparation order) an optional barcode reader can be used with SampleRail™.

Two barcode reader versions are available:

- A stationary CCD barcode reader P/N HZ10192
- A stationary 2D barcode reader P/N H14100

The barcode reader is attached to the SampleRail control unit at the connector labeled BARCODE. Data transfer is made via an RS232 connection, configured with the following parameters:

Baud rate:	9600
Data bits:	8
Parity:	no
Stop bit:	1
Protocol:	no



When a barcode reader is used with the BSR control unit, it will be automatically recognized when the control unit is turned on or reset. A Sample-ID and Tube-ID are automatically generated.

Definition of the 'Sample-ID' and 'Tube-ID' used within the SampleRail system:

- The **Sample-ID** is the identification of the sample used during delivery of the sample to the Tecan robot and during the preparation within the robot. The Sample-ID is attached as a barcode to the vial or it results from the placement of the sample in a well plate.
- The **Tube-ID** is the (temporary) identification of the sample after the preparation - during the transportation of the sample to the Spectrometer using SampleRail and during the NMR measurement. The Tube-ID is attached as a barcode to the NMR tube.

Operation without a Barcode Reader

When a barcode reader is not available, the Tecan robot will use the Sample-ID as the Tube-ID, and send this to the BSR control unit after inserting a sample onto the trolley.

Operation with a Barcode Reader

When a barcode reader is used, the actual Tube-ID is read from the barcode on the NMR tube and sent to the BSR control unit after a sample is inserted onto the trolley.

In either case the NMR samples can be positively identified during the whole operational sequence, allowing simplified sample exchange and recognition.

The CCD Barcode Reader

11.2

The CCD barcode reader is reconfigured with each initialization of the control unit. The following parameters are used:

- Handshake: Free Running
- Read Mode: Single Read
- Time Out: 1 second
- Bad Read: "BR", CR
- Code 128 and Code 2/5 interleaved
- Redundancy: 4 agreeing readings
- Buzzer: Off
- Suffix: CR

The barcode reader is installed using a mounting plate at the vertical transportation cylinder. The barcode reader can be mounted in the left or right position, depending on the SampleRail setup.



Figure 11.1. The CCD Barcode Scanner

The 2D Barcode Reader

11.3

The 2D barcode reader offers a higher reading reliability than the CCD reader, particularly in the case of dirty or defective barcodes. Reading errors may result in the automation being interrupted or the appropriate sample not being measured.

The configuration of the 2D barcode reader is stored in the reader memory. The barcode reader is automatically recognized with each initialization of the control unit. The following parameters are stored in the reader memory:

- Code 128
- Code 2/5 interleaved
- Beeper: on
- Power hold mode: on

The barcode reader is installed using a mounting plate on the frame of SampleRail. The mounting plate can be adapted to the individual SampleRail installation.



Figure 11.2. The 2D Barcode Reader

Standard Accessories

12

BSR Accessories

12.1

Sample Accessories

12.1.1

Table 12.1. BSR Sample Accessories

Accessory	Part No.
Spinner SB Pla (Pom) 5+2,5	Z42516
Sample Tube 5 mm 7" Royal Imp.	H100
Sample Tube Caps 5 mm 100st	8529
Set Barcode Holder Vertical Barcode X100 D=5.1	H10113

The sample accessories are not included with delivery of the BSR and need to be ordered separately.

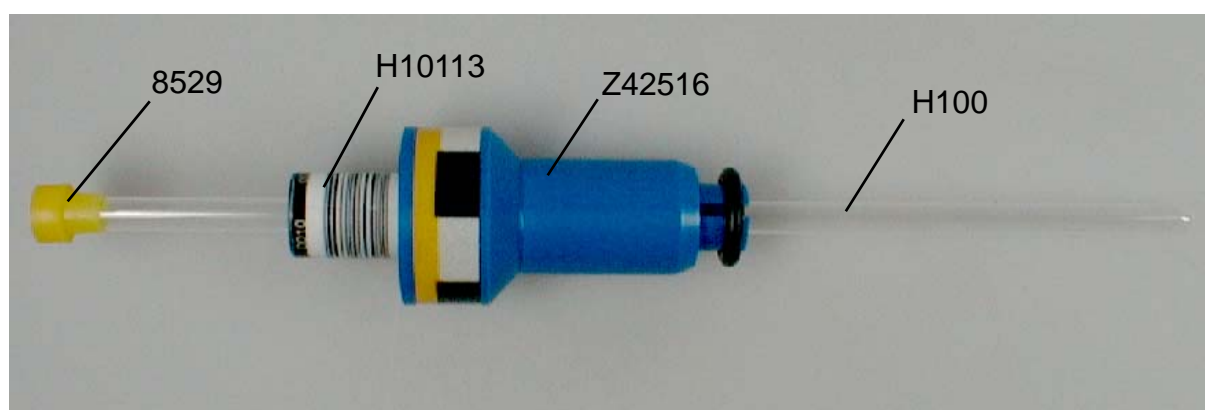

Figure 12.1. SampleRail Sample Accessories

The following standard accessories are delivered with the BSR:

Table 12.2. Standard Accessories BSR (P/N H10006)

Accessory	Part No.
Slow speed grease for pneumatic cylinders without piston rod	68482
Wrench set for socket head cap screws	69806
Screwdriver for cross-slotted screws size 1	9117
Screwdriver for cross-slotted screws size 2	14931
Screwdriver 2.5 x 0.5	69880
Screwdriver 4.0 x 0.6	9113
Screwdriver 6.5 x 1.0	14977
Adjusting device for transfer unit SampleRail / magnet	HZ07505
Adjusting device for mounting flange of flexible tube	HZ07808
Tool chest	69670
This manual.	Z31571

BSR VAC Accessories

12.2

Sample Accessories

12.2.1

The sample accessories are not included in delivery of the BSR VAC and need to be ordered separately.

Table 12.3. Sample Accessories for BSR VAC

Accessory	Part No.
BSR VAC Disposal Collar 4,25 mm Imp	HZ12517
BSR VAC Barcode bracket 500 Pcs	H10165
BSR VAC Septum D=10.3/t=1.3 mm Cross Lot	HZ12714
MATCH Sample Tube 4.25x100 mm 10 pcs.	HZ12654
BSR VAC DISPOSAL ADAPTER 60MM	HZ12531
BSR VAC Spinner Retainer New Disposal	HZ12442

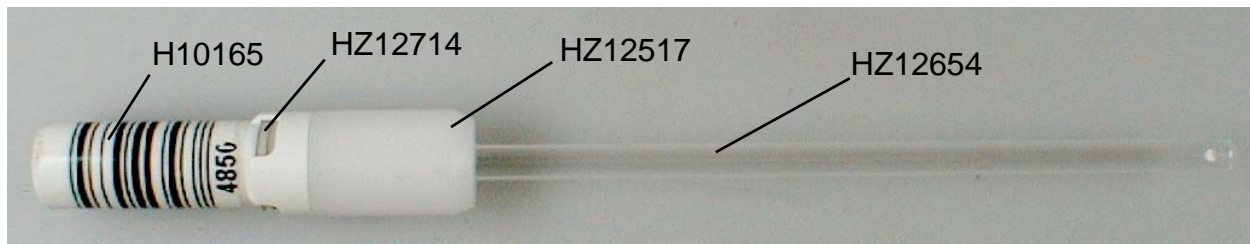

Figure 12.2. BSR VAC Tube Assembly Complete

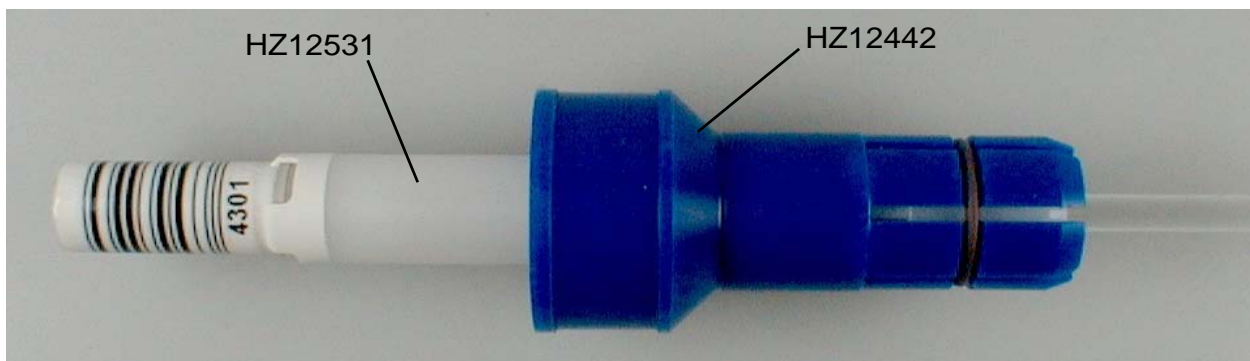

Figure 12.3. BSR VAC Disposal Adapter Spinner

The following standard tool accessories are delivered with the BSR VAC:

Table 12.4. Standard Tool Accessories BSR VAC (Part No. H12204)

Accessory	Part No.
Slow speed grease for pneumatic cylinders without piston rod	68482
Wrench set for socket head cap screws	69806
Screwdriver for cross-slotted screws size 1	9117
Screwdriver for cross-slotted screws size 2	14931
Screwdriver 2.5 x 0.5	69880
Screwdriver 4.0 x 0.6	9113
Screwdriver 6.5 x 1.0	14977
Adjustment tool transfer BSR VAC / magnet	HZ12699
BSR VAC auxiliary tool nozzle- cone	HZ13047
BSR VAC auxiliary tool spiral	HZ13069
Tool chest	69670
This manual	Z31571

Power Supply Requirements

13.1

Input voltage range:	85-264VAC
Input frequency range:	47 - 440Hz
Power consumption:	45VA
Degree of pollution:	2
Over voltage category:	2

Fuse Protection

13.2

2 x 1AT (slow-blow fuse)

Compressed Air Requirements

13.3

Input pressure BSR:	5.0 - 6.0 bar (72 - 87 psi)
Input pressure BSR VAC:	6.0 - 7.0 bar (87 - 102 psi)
Absolute max. pressure:	8.0 bar (116 psi)
Air consumption:	100 l/minute

Nitrogen or clean, dry and oil-free compressed air is required.

A compressed air supply, complete with a pressure control valve and a stop valve (meeting EN 983 standards) needs to be provided by the customer.

Serial Communication

13.4

The serial communication ports leading from the SampleRail control unit rear panel, to the spectrometer host computer, and to the control PC of the preparation robot (marked 'HOST' and 'TECAN' respectively) are configured as follows:

- 9600 Baud
- 8 Data bits
- No parity
- 1 stop bit
- No protocol

Noise Level

13.5

Emitted noise level: < 60dB (A)

Environmental Requirements

13.6

SampleRail should only be used:

- in a standard laboratory environment;
- up to a height of 2.000 meters;
- at a temperature of 15 to 35°C;
- where the highest relative humidity of 80% for temperatures to 31°C, linear decreasing to 67% relative humidity to 35°C.

SampleRail should only be stored in an area:

- similar to a laboratory environment;
- with a temperature range of 5 to 40°C;
- where the highest relative humidity of 80% for temperatures to 31°C, linear decreasing to 50% relative humidity to 40°C.

Figures

1 Introduction	9
Figure 1.1. The BRUKER SampleRail and the TECAN Robot	9
2 Safety Considerations	13
Figure 2.1. Warning Symbol at the Hood/Enclosure of SampleRail	19
Figure 2.2. Alternative Warning Symbol on SampleRail	20
Figure 2.3. Warning Label at the Rear Panel of the SampleRail Controller	20
3 System Description	21
Figure 3.1. The Bruker SampleRail System	21
Figure 3.2. SampleRail Communication Block Diagram	23
Figure 3.3. Example of a SampleRail System	23
Figure 3.4. Example of a BSR VAC System	24
Figure 3.5. The BSR SampleRail Type Label	25
Figure 3.6. The BSR Control Unit Type Label	25
Figure 3.7. BSR Pneumatic Unit Type Label	25
4 Installation Instructions	27
Figure 4.1. Attaching the Horizontal Arm	27
Figure 4.2. Pneumatic Unit Rear Panel	28
Figure 4.3. BSR Pneumatic Connections	29
Figure 4.4. Pneumatic Connections BSR VAC	30
Figure 4.5. Control Unit Rear Panel	31
Figure 4.6. Electric Connections BSR	32
Figure 4.7. Electric Connections BSR VAC	33
Figure 4.8. BSR Flexible Tube Components at the Shim Upper Part	34
Figure 4.9. BSR VAC Flexible Tube Components at the Shim Upper Part	38
5 Settings and Adjustments	41
Figure 5.1. Valve to Adjust Lift Air Flow	41
Figure 5.2. BSR Pneumatic Unit - Rear Side	42
Figure 5.3. BSR Sample Down Unit ECL 00	43
Figure 5.4. BSR Sample Down Unit ECL 01	44
Figure 5.5. Adjusting the BSR Sample Down Unit	44
Figure 5.6. Adjusting the Sample Down Fiber Amplifier	45
6 Operating Instructions	47
Figure 6.1. The BSR Control Unit Front Panel	47
Figure 6.2. Eject and Insert Position in the SampleRail Trolley	50

7	Software Commands	51
8	Communication with the Tecan Robot	69
9	Error Handling	73
10	Operator Maintenance	77
	Figure 10.1. Horizontal Cylinder	78
	Figure 10.2. Vertical Cylinder	78
	Figure 10.3. Horizontal Arm Joint Components	79
	Figure 10.4. Workflow for Rotating the BSR	82
	Figure 10.5. Workflow for Rotating the BSR VAC	83
	Figure 10.6. The Vertical Hood	85
	Figure 10.7. Removing the Vertical Covering	86
	Figure 10.8. Removing the Horizontal Covering	87
11	Barcode Reader Option	89
	Figure 11.1. The CCD Barcode Scanner	91
	Figure 11.2. The 2D Barcode Reader	92
12	Standard Accessories	93
	Figure 12.1. SampleRail Sample Accessories	93
	Figure 12.2. BSR VAC Tube Assembly Complete	95
	Figure 12.3. BSR VAC Disposal Adapter Spinner	95
13	Technical Data	97

Tables

1	Introduction	9
2	Safety Considerations	13
3	System Description	21
4	Installation Instructions	27
5	Settings and Adjustments	41
6	Operating Instructions	47
7	Software Commands	51
Table 7.1.	Standard Commands	52
Table 7.2.	Standard Commands for BACS Compatibility	57
Table 7.3.	Error Mode Commands	59
Table 7.4.	Diagnostic Mode Commands	60
8	Communication with the Tecan Robot	69
Table 8.1.	Commands for TECAN Robot	69
9	Error Handling	73
Table 9.1.	Errors requiring user intervention	73
Table 9.2.	Errors in the Communication Between SampleRail and Host Computer	76
10	Operator Maintenance	77
11	Barcode Reader Option	89
12	Standard Accessories	93
Table 12.1.	BSR Sample Accessories	93
Table 12.2.	Standard Accessories BSR (P/N H10006)	94
Table 12.3.	Sample Accessories for BSR VAC	95
Table 12.4.	Standard Tool Accessories BSR VAC (Part No. H12204)	96
13	Technical Data	97

Index

A

Accessories	93
Air pressure	
Input	42
Applications	9
Automatic Mode	14
Automatic mode	48

B

Barcode Reader	
2D	91
CCD	90
Operating without	90
Barcode reader	89
BSR VAC	
Description	24

C

CCD barcode reader	89
Cleaning	17
Commands	51
Diagnostic Mode Commands	60
Error Mode Commands	59
For TECAN Robot	69
Standard commands	52
Standard commands for BACS compatibility	57
Structure of a command	69
Compressed air	28
Compressed air supply	42
CONT	50
Control Unit Rear Panel	31
Customer responsibilities	18

D

Description	
Subassemblies	21
Diagnostic Mode	51

E

Electric Connections	
BSR	32

BSR VAC	33
Electrical Connections.....	31
Error Messages.....	73
Communication Errors	76
Errors requiring user intervention.....	73
Structure	73
Errors	73
 F	
Failure	50
Fiber Amplifier	
Adjustment	45
First Start.....	15
Front Panel Controls	47 – 48
 G	
Glass tubes	15
 H	
Hazards.....	15
Horizontal Unit	
Length	21
 I	
Initialization	47
Installation	18, 27
Flexible tube connection BSR.....	34
Flexible tube connection BSR VAC	38
 L	
LIMS.....	9
 M	
Maintenance.....	16
Manual Eject	49
Manual Insertion Mode.....	14
Manual insertion mode.....	48 – 49
Manual mode	48
 O	
Operation	16
Operation mode commands.....	52
Operator Maintenance	77
After tube breaks.....	79
Cleaning.....	77

Cleaning solvents.....	77
Horizontal and vertical units.....	78
Horizontal arm.....	79
Protective hoods & enclosures	85
Sliding surfaces.....	78
Vertical cylinder.....	78
 P	
Pneumatic Connections	28
BSR.....	29
BSR VAC	30
Pressure regulating valve.....	42
 R	
RS232	69
 S	
Safety	
Dangers from moving parts.....	19
Electrical parts	20
Repair work.....	19
Safety instructions.....	13
Sample accessories	95
Sample Down Unit	44
Sample trolley	22
SampleRail	
Control unit.....	22
Installation.....	27
Pneumatic unit	22
Purpose.....	9
Safety instructions.....	13
Type label	25
Settings and Adjustments	41
Air flow for sample lift.....	41
Buffer air for sample lift.....	42
Sample Down Unit	43
Suction air for BSR VAC sample lift.....	42
Temperate air flow for BSR VAC	43
Starting the system	47
Structural requiements.....	27
 T	
TECAN.....	22, 69
TECAN Genesis Freedom	9
TECAN pipetting robot	21
Tools	94
Trademarks.....	10
Transfer Unit	22
Transportation.....	14

V

Vertical Unit	
Length	21
Vibrations	27



Notes: