

**AQS ACB**  
**Standard Board**

**User Manual**

**Version 001**

---

**BRUKER**

---

The information in this manual may be altered without notice.

BRUKER accepts no responsibility for actions taken as a result of use of this manual. BRUKER accepts no liability for any mistakes contained in the manual, leading to coincidental damage, whether during installation or operation of the instrument. Unauthorised reproduction of manual contents, without written permission from the publishers, or translation into another language, either in full or in part, is forbidden.

This manual was written by

Eamon Butler and Thomas Wunderle

© July 7, 2000: Bruker Analytik GmbH

Rheinstetten, Germany

P/N: Z31590

DWG-Nr: 1302001

# Contents

	<b>Contents .....</b>	<b>3</b>
<b>1</b>	<b>ACB Configurations.....</b>	<b>5</b>
1.1	Introduction .....	5
1.2	First generation Avance systems .....	5
1.3	Second generation Avance systems .....	5
<b>2</b>	<b>Basic Functions.....</b>	<b>9</b>
2.1	Introduction .....	9
2.2	Primary Function .....	9
2.3	Secondary Functions .....	9
2.4	Cables and Part Numbers .....	10
<b>3</b>	<b>Connections to BSMS Keyboard.....</b>	<b>13</b>
3.1	Introduction .....	13
3.2	Signal Description .....	13
<b>4</b>	<b>Connections to HPPR.....</b>	<b>17</b>
4.1	Introduction .....	17
4.2	Signal description .....	17
<b>5</b>	<b>Additional Information.....</b>	<b>19</b>
5.1	Switching on / Initialization Routine .....	19
5.2	Firmware Update .....	19
5.3	Power Supply .....	19
5.4	ECL Level .....	19
5.5	Board Replacement. ....	19
<b>6</b>	<b>Appendix.....</b>	<b>21</b>
6.1	Introduction .....	21
	<b>Figures .....</b>	<b>25</b>
	<b>Tables .....</b>	<b>27</b>



# ACB Configurations

# 1

---

## Introduction

1.1

The ACB (Amplifier Control Board) is a slot-in board used in all Avance systems. There are however various types available depending on the system.

---

## First generation Avance systems

1.2

First generation Avance systems were shipped with the original AQR ACB board (H5483). If your system has an AQX / AQR chassis with boards such as the ASU (Amplitude Setting Unit), the LOT (Local Oscillator Tune) as well as a PTS or Schomandl frequency synthesizer etc. then this is the relevant ACB board for your system. The AQR ACB board is **not** described in this manual but is described in manual P/N Z31224.

---

## Second generation Avance systems

1.3

With the more recent AQS system with units such as the FCU3, TCU3, SGU two ACB configurations are possible depending on whether the system amplifiers are internal or external.

1) The AQS ACB **Standard Board ACB-S** (H9488) is designed to be used in Avance systems fitted with **internal** amplifiers (BLA2BB, BLAX300) mounted within the AQS rack. The board is positioned at the rear of the rack as in **Figure 1.1. on page 6**

2) The AQS ACB **Extended Board ACB-X** (H9500) is designed to be used in Avance systems fitted with **external** amplifiers. The ACB Extended Board is used in conjunction with the AQS **PSD** Board (H9530). Slot positions of these two boards are shown in **Figure 1.2. on page 7.**

This manual describes the AQS ACB **Standard** Board.

# ACB Configurations

Figure 1.1. Position of the ACB Standard Board ACB-S at the rear left of the QQS rack.

## Rear of QQS Rack

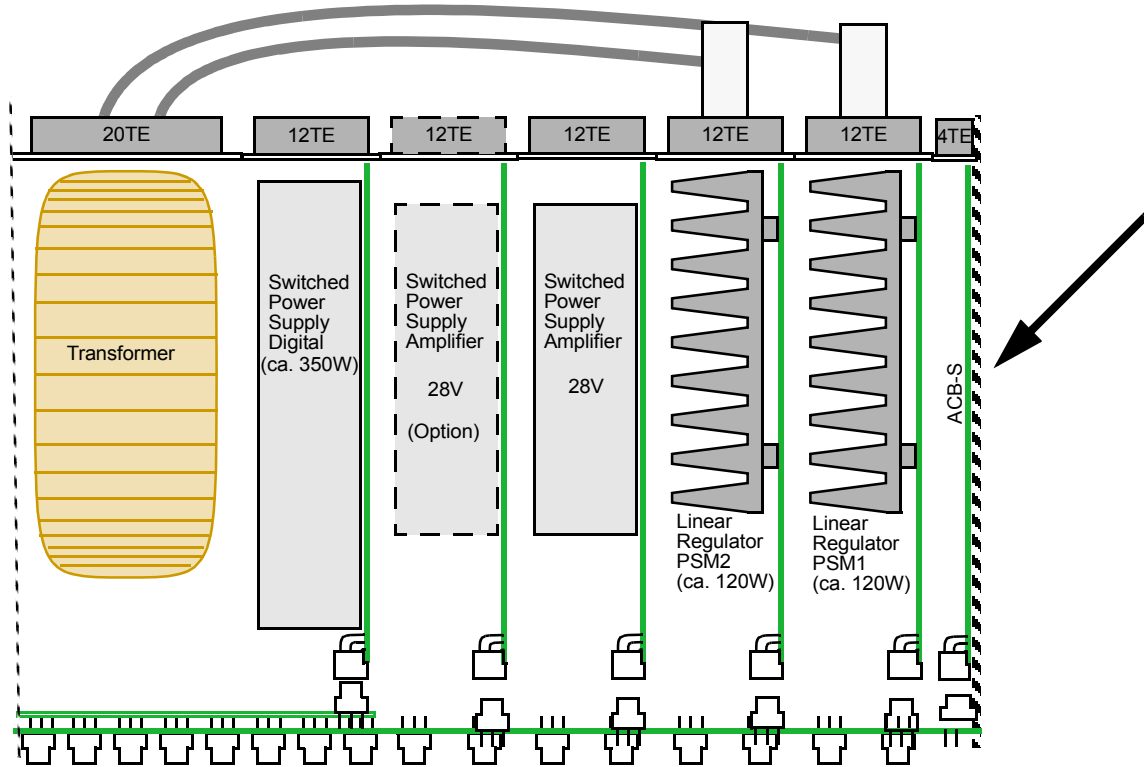
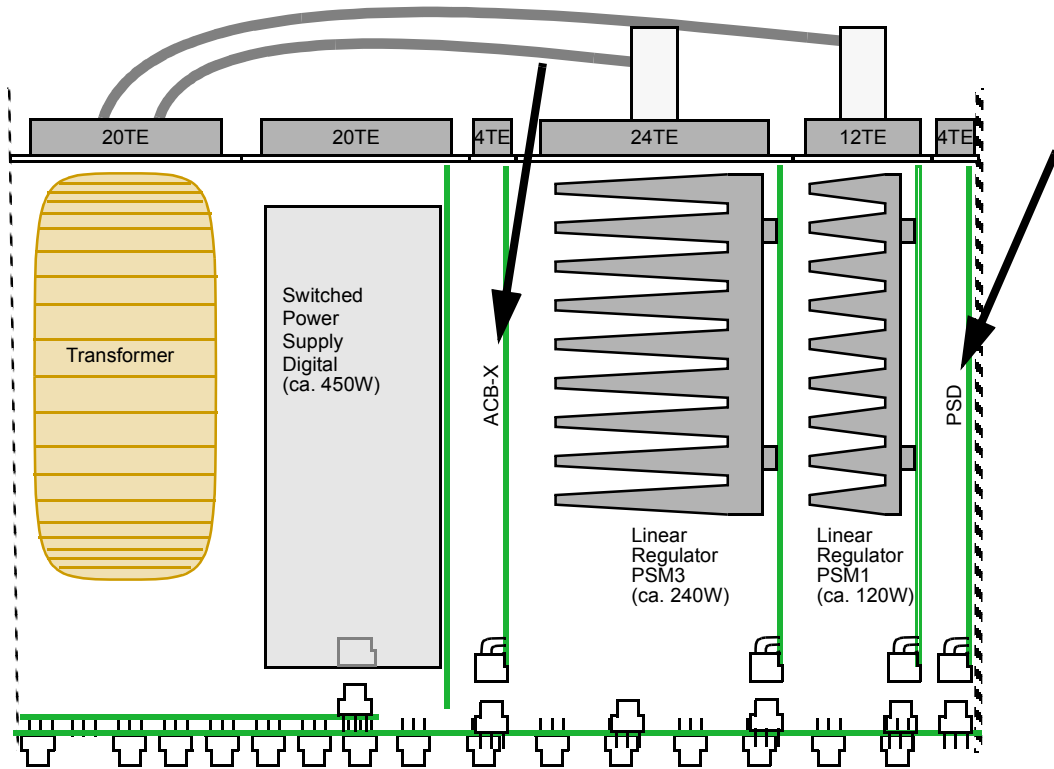

Figure 1.2. Position of the ACB Extended Board ACB-X and the AQS PSD Board at rear of the AQS rack.

Rear of AQS Rack







# Basic Functions

# 2

## Introduction

2.1

In order to reduce costs the ACB standard board (ACB-S) has been designed with limited on-board processing capability and in many of its functions it acts simply as a buffer for signals that need to be transmitted to various units. The ACB standard board is connected to

- the internal linear amplifiers via the I<sup>2</sup>C bus along the AQS backplane
- the (optional) BSMS keyboard via the BSMS CCU
- the HPPR1 via the Console Backpanel and 19 pole periphery connection.
- the HPPR2 via the Console Backpanel and 36 pole periphery connection.

## Primary Function

2.2

The primary function of the ACB-S is to display the forward (FORW) and reflected (REFL) linear amplifier power on the BSMS keyboard (when such an option is fitted). The information is transmitted from the linear amplifiers to the ACB-S using the I<sup>2</sup>C bus which runs along the AQS backplane. The information is then transmitted to the BSMS keyboard via the BSMS CCU.

**Note** A power display on the graphics monitor is not supported with the ACB-S. To see the FORW and REFL display on the monitor a system fitted with the ACB Extended board along with external amplifiers is required.

## Secondary Functions

2.3

Secondary functions of the ACB-S are listed below.

- Transmission of the Power down ('Trans P-Down') signal from the BSMS keyboard.
- Transmission of the 'Chan Select' signal from the BSMS keyboard
- Transmission of the 'RGP ADC' signal to the BSMS keyboard.
- Provision of the power supply voltages  $\pm 19$  V, +9V to the HPPR.
- Transmission of the 'RGP HPPR' signal to the HPPR
- Transmission of the 'Lock PP' (TGPF0) signal to the HPPR (old name SPF0)
- Transmission of the 'Interleave Inc.' (old name RCP) signal to the HPPR (HPPR2 only).
- Buffer of the 20MHz synchronization clock signal

## Basic Functions

As can be seen from the above list the two principal units with which the ACB-S communicates externally (as opposed to over the AQS backplane) are the BSMS and the HPPR and these are the subject of the next two chapters.

### **Cables and Part Numbers**

**2.4**

The table below is a list of the external cabling.

*Table 2.1. ACB-S Cables and part numbers*

ACB-S Front Panel Label	From	To	P/N
HPPR	ACB-S	Backpanel	Console wiring
HPPR PSU	ACB-S	Backpanel	Console wiring
TGPF0	BSMS LTX	ACB-S	Console wiring
BLKTR4	NC		
Display Data Out	ACB-S	BSMS CCU	22886
SBS-BUS CH2	NC		

The figure "**ACB-S Front panel**" on **page 11** shows the various connections.

Figure 2.1. ACB-S Front panel

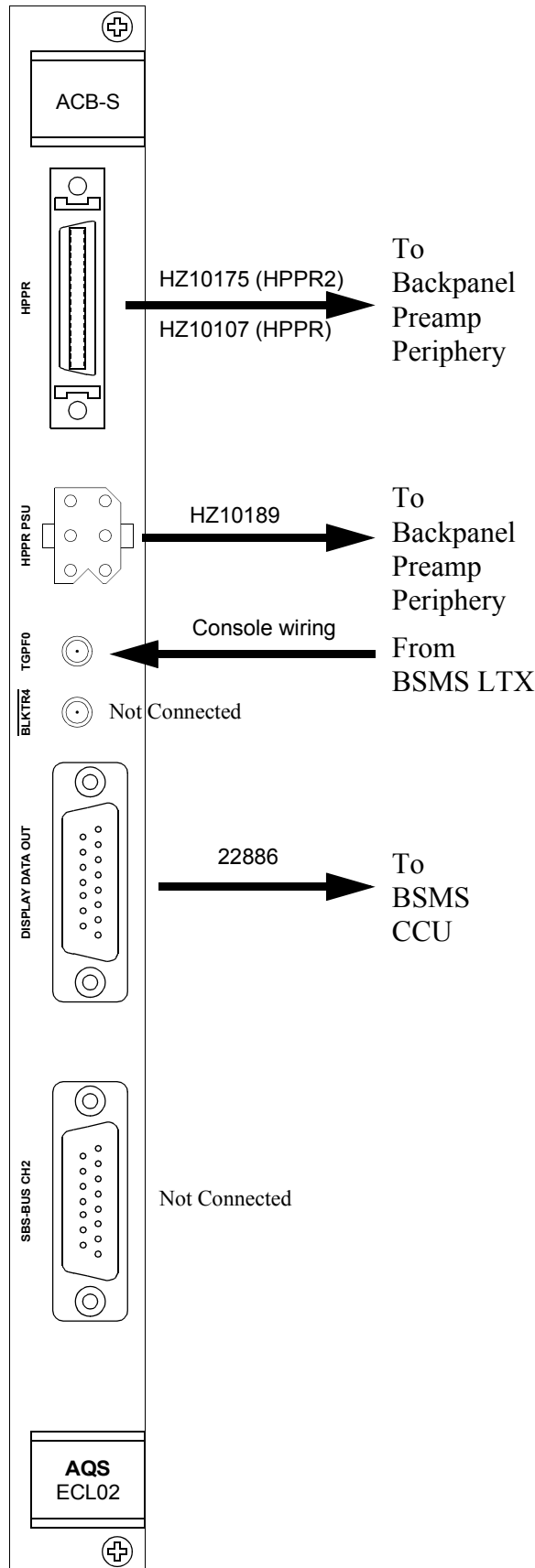



# Connections to BSMS Keyboard

# 3

## Introduction

3.1

The ACB-S is linked via the CCU of the BSMS to the BSMS keyboard as in the figure ["ACB-S connections with the BSMS" on page 14](#)

The next section describes the various signals that are transmitted between the ACB-S and the BSMS. The pinouts of the various signals are listed in the Appendix.

## Signal Description

3.2

### **Display of FORW and REFL power**

Each RF amplifier has internal ADCs (8 bits resolution) which digitize the rf power as measured at the amplifier output. Both available amplifier slots are continuously polled by the ACB-S to sample the magnitude of the forward and reflected signal. The data transmission is achieved using the I<sup>2</sup>C bus which runs along the AQS backplane and effectively connects the ACB-S with the amplifiers. The data transfer can only take place when the ACB-S is allowed take control of the bus. The SGU is however normally Master of the I<sup>2</sup>C bus. At the appropriate time the SGU will send a 'I<sup>2</sup>C Bus request' signal that allows the ACB-S to become Master of the I<sup>2</sup>C Bus. Under these conditions a data bit stream containing the FORW and REFL information is received by the ACB-S without interruption. This condition will continue until such time as the SGU becomes Master once again by effectively removing the 'I<sup>2</sup>C Bus request'.

The digitized information is then passed to the BSMS CCU and then to the BSMS keyboard where, still in digital form, it is used to light the LED display on the BSMS keyboard.

**Note 1:** There is no need to individually address the linear amplifiers as all potential amplifier slots will be polled. This is not the case however if external amplifiers are used.

**Note 2:** Because of the digital nature of the FORW and REFL signals they are not open to troubleshooting.

### **Control of the ADC LED on the BSMS keyboard**

This LED is controlled by the 'RGP ADC' signal which is transmitted along the AQS Backplane after generation by the SGU. The ACB-S simply buffers this signal and it is then transmitted to the BSMS keyboard. The signal is ACTIVE LOW corresponding to the ADC 'on' condition.

# Connections to BSMS Keyboard

Figure 3.1. ACB-S connections with the BSMS

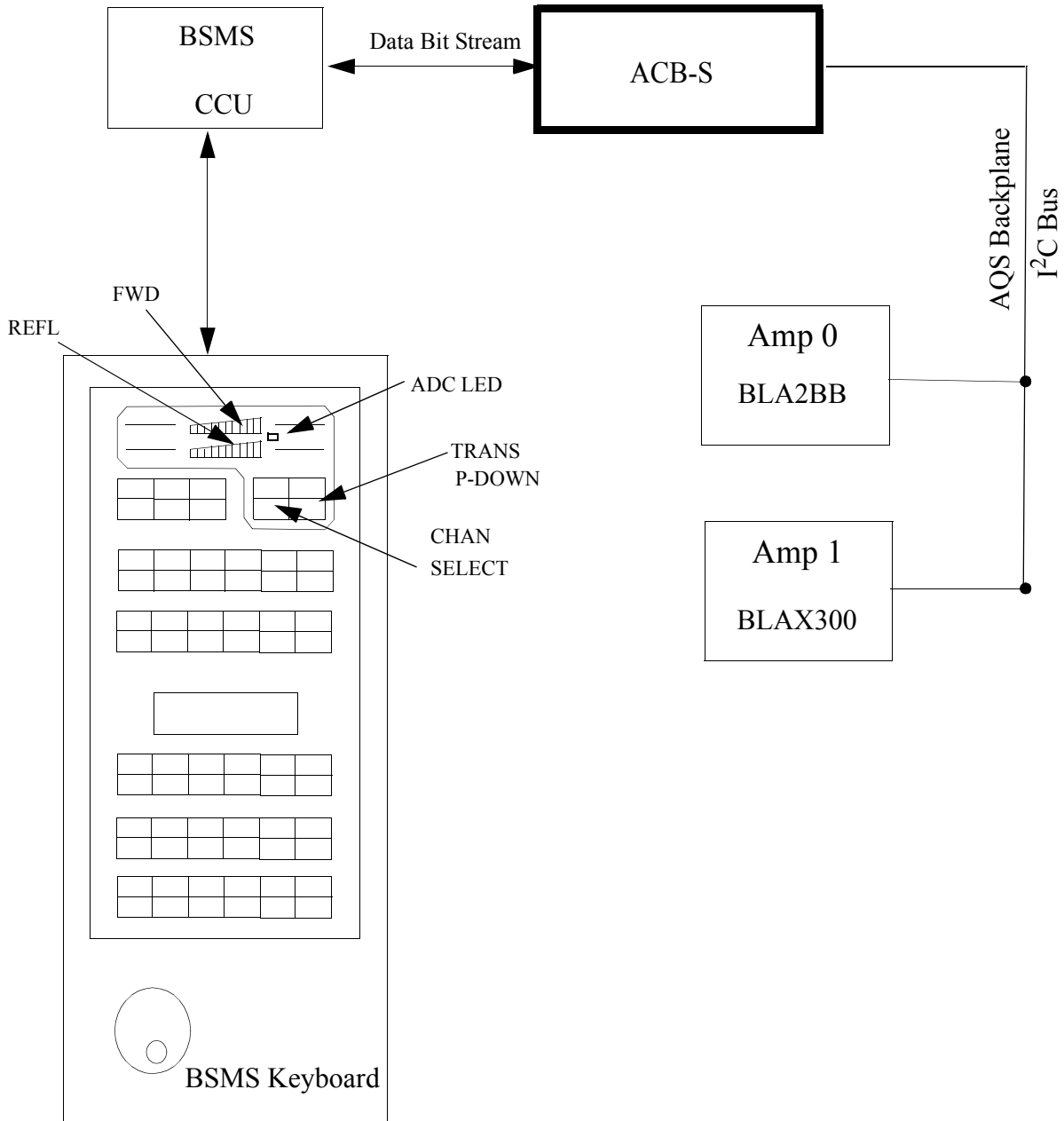

**Transmission of Power down (Trans P-Down) signal from BSMS keyboard.**

When the Trans P-Down key on the BSMS keyboard is pressed the ACB-S will cause the Emergency Powerdown pulse to be set high thus disabling all internal amplifiers. The signal is ACTIVE LOW corresponding to zero power transmission.

### ***Transmission of 'Chan. Select' signal from BSMS keyboard***

By pressing the 'Chan Select' key on the BSMS keyboard, the RF channel that is used to display the FORW and REFL power displays can be selected. The ACB-S can poll all available amplifiers and display the power of the chosen channel.

**Note:** Unlike previous ACB versions the OBS LED as well as the transmitted pulse LED's on the BSMS keyboard are not controlled by the ACB-S.





# Connections to HPPR

# 4

## Introduction

## 4.1

The ACB-S is linked via the cabinet Backpanel to the HPPR.

The next section describes the various signals that are transmitted between the ACB-S and the HPPR.

The pinouts of the various signals are detailed in the Appendix.

## Signal description

## 4.2

### **+9 V, ± 19V DC Power supplies to HPPR.**

Note that this connection labeled 'HPPR PSU' on the front panel was introduced with ECL002.

The origin of the voltages are the power supply boards AQS PSM1 and PSM2 and the ACB-S serves only to transmit these signals to the HPPR.

These voltages are delivered to the HPPR and can most easily be measured at the 19 pole Preamp Periphery socket or on the HPPR Cover display itself. The pinouts for these signals are given in the table below.

Table 4.1. ACB-S HPPR signals.

Signal from ACB -S	ACB-S front panel Pinout	19 Pole HPPR Periphery Socket	HPPR Cover display
+19V	X8 HPPR PSU Pin 6	A	JOA
-19V	X8 HPPR PSU Pin 3	L	JOL
+9V	X8 HPPR PSU Pin 2	N	JON
RGPHPPR	X2 HPPR Pins 18/36	G	JOG
Lock PP	X2 HPPR Pins 17/35	F	JOF

### ***RGP HPPR (EP):***

This signal is generated by the SGU and transmitted to the ACB-S along the AQS backplane. From here it is connected to the Backpanel and then to the HPPR via the 19 pole Preamp Periphery socket (HPPR1) or the 36 pole Preamp Periphery socket (HPPR2). The purpose of the signal is to control the switching of the HPPR between transmit and receive mode. The ACB-S acts merely as a buffer and simply passes the signal on to the HPPR.

**Note:** This signal was formerly referred to as EP.

### ***LOCK PP (TGPF0)***

This is the gating pulse for the lock preamplifier. The signal is pulsed at the frequency of 6.6kHz (regardless of whether a 2H or a 19F lock is used). The signal originates on the BSMS LTX board and is transmitted to the ACB-S via the external sma type cable which is connected to the ACB-S front panel.

**Note:** On earlier Avance instruments this signal was known as SPF0.

### ***INTERLEAVE INC (RCP)***

This signal has not yet been implemented. The signal could be used for fast switching between the selected preamps during a pulse program where the RS232 control would be too slow. This would allow the selected OBS HPPR module to be switched during an acquisition. This feature may be implemented in the future HPPR2 model. The signal is generated by the SGU and transmitted to the ACB-S. From here it is connected to the Backpanel and then to the HPPR2 via the 36 pole Preamp Periphery socket (HPPR2)

**Note:** The signal was formerly referred to as RCP.

### ***20MHz clock signal***

This signal is used to ensure FCU and SGU synchronization. The ACB-S acts merely as a buffer. The signal is transmitted along the AQS backplane.

# ***Additional Information***

# **5**

---

## ***Switching on / Initialization Routine*** **5.1**

---

The ACB-S requires no initialization due to the simplicity of the on board microprocessors. Once the board has been switched on it is ready to function.

---

## ***Firmware Update*** **5.2**

---

There is no download possibility as firmware updates will not be required. The firmware will not be updated with new XWIN-NMR versions.

---

## ***Power Supply*** **5.3**

---

The board requires 5V(Vcc) and +12V (SBS) power supply. Both of these voltages are taken from the corresponding PSM Modules over the backplane.

---

## ***ECL Level*** **5.4**

---

Current level (March 2000) is ECL002. This level was the first to be shipped to customers. With the introduction of ECL002 (2/12/99) an additional power supply connector for the HPPR2 was added to the front panel

---

## ***Board Replacement.*** **5.5**

---

This requires no special precautions. Simply power off the console and replace.

**Additional Information**

This chapter contains the following figures

"Block Diagram" on page 22

"Connector Pinouts" on page 23

"Component Layout" on page 24

Figure 6.1. Block Diagram

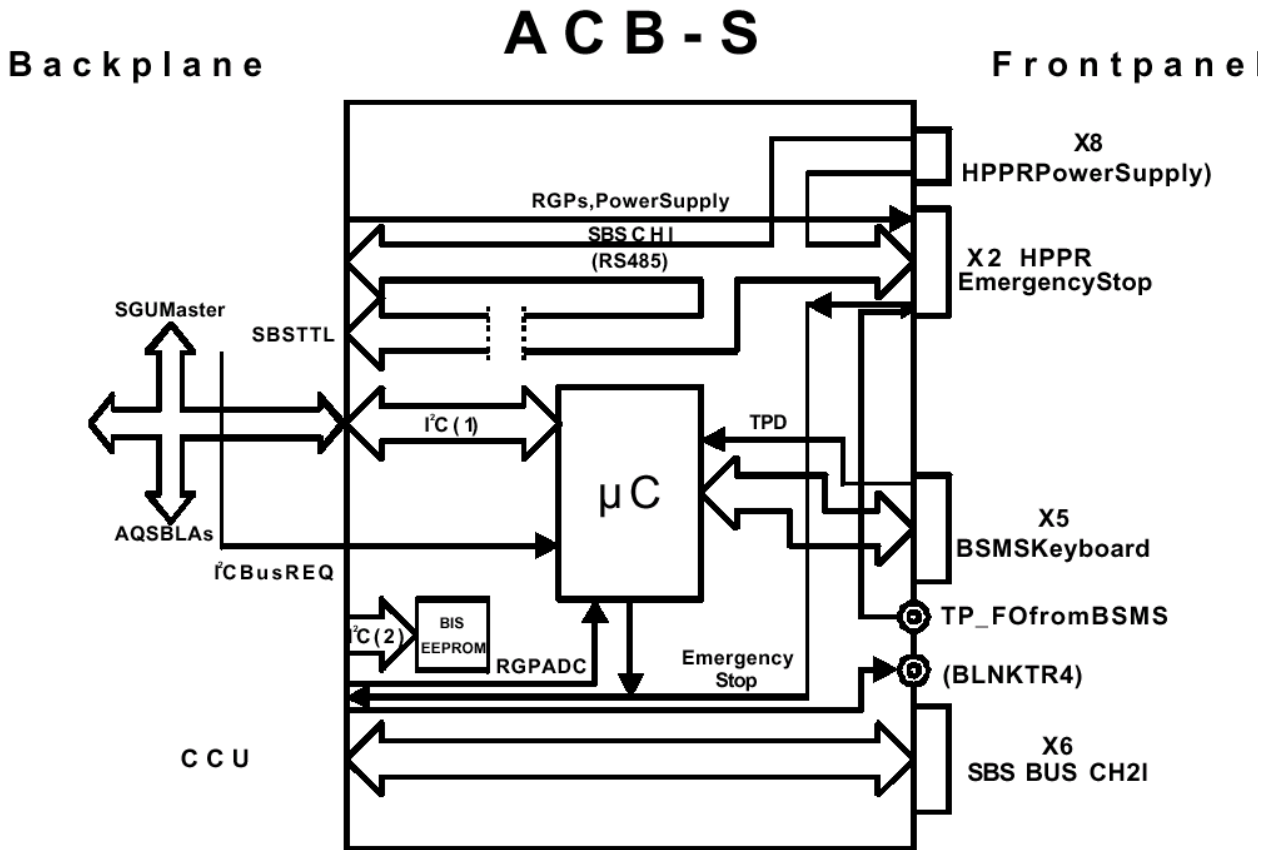

Figure 6.2. Connector Pinouts

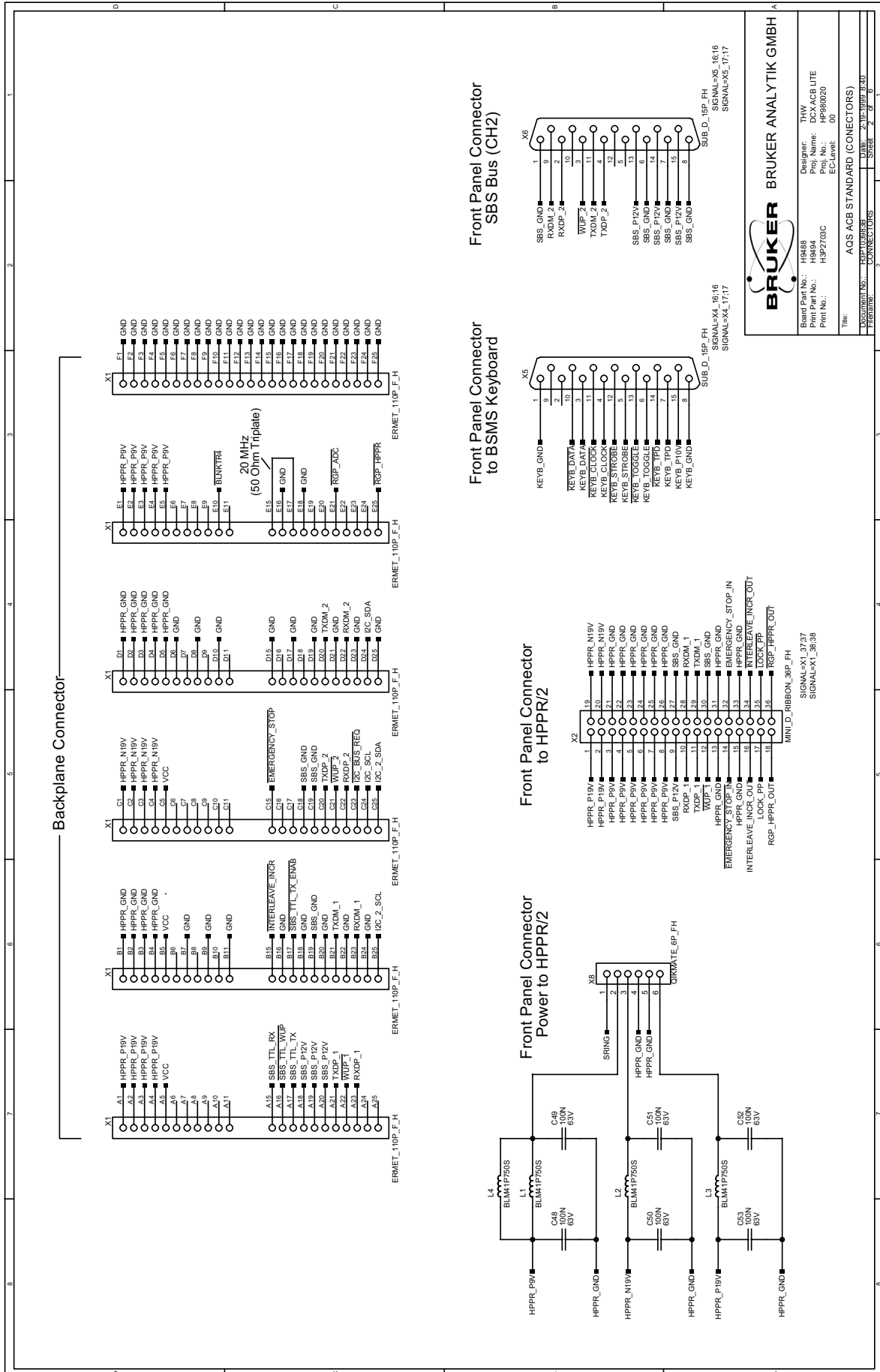
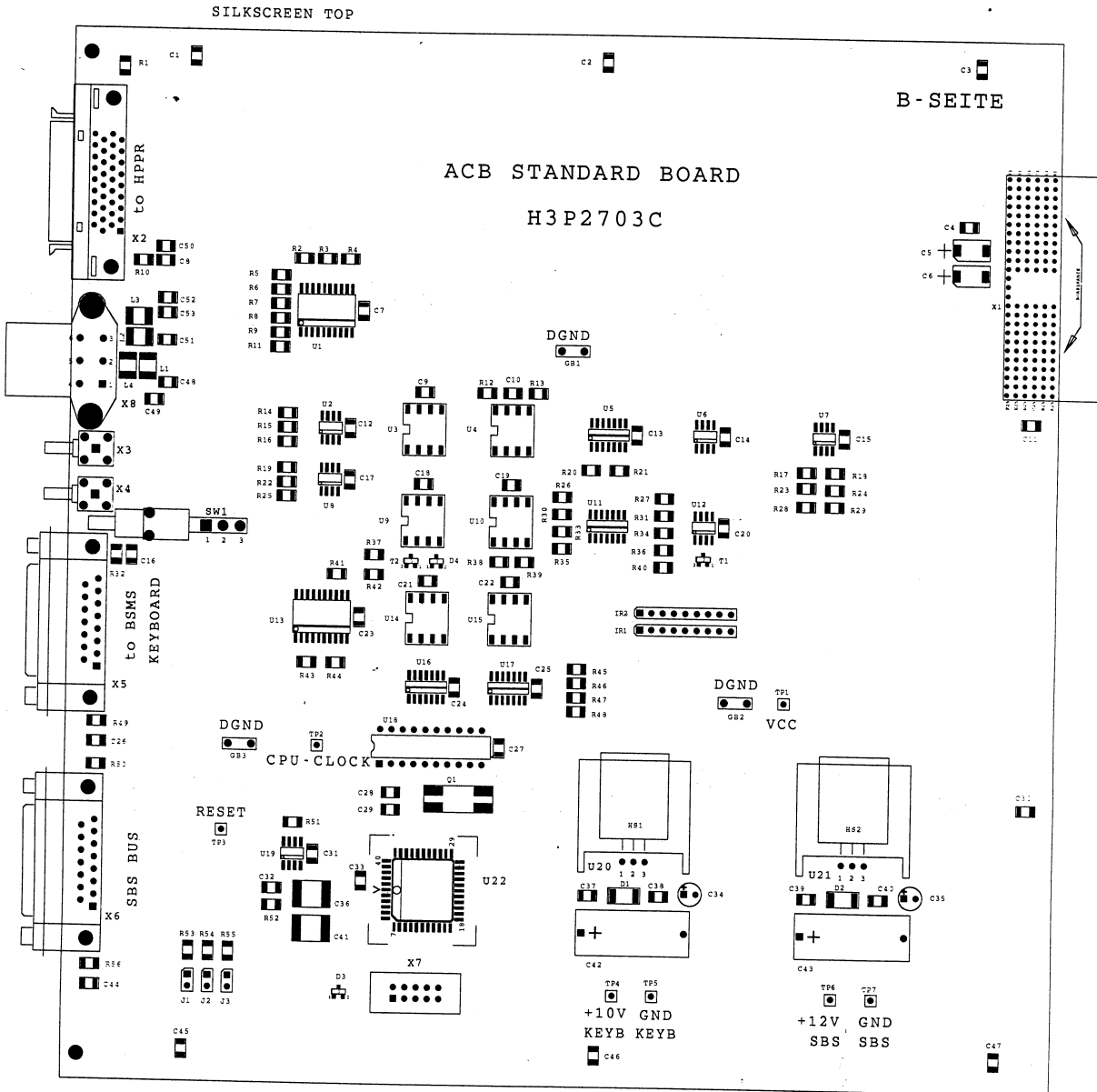

Figure 6.3. Component Layout



BRUKER

PRINTFORMAT 220mmX233,35mm  
 ACB STANDARD BOARD H3P2703C  
 DAT 22-02-1999



# Figures

<b>1</b>	<b>ACB Configurations</b>	<b>5</b>
Figure 1.1.	Position of the ACB Standard Board ACB-S at the rear left of the AQS rack. ....	6
Figure 1.2.	Position of the ACB Extended Board ACB-X and the AQS PSD Board at rear of the AQS rack. ....	7
<b>2</b>	<b>Basic Functions</b>	<b>9</b>
Figure 2.1.	ACB-S Front panel .....	11
<b>3</b>	<b>Connections to BSMS Keyboard</b>	<b>13</b>
Figure 3.1.	ACB-S connections with the BSMS .....	14
<b>4</b>	<b>Connections to HPPR</b>	<b>17</b>
<b>5</b>	<b>Additional Information</b>	<b>19</b>
<b>6</b>	<b>Appendix</b>	<b>21</b>
Figure 6.1.	Block Diagram .....	22
Figure 6.2.	Connector Pinouts .....	23
Figure 6.3.	Component Layout .....	24



# Tables

<b>1</b>	<b><i>ACB Configurations</i></b>	<b>5</b>
<b>2</b>	<b><i>Basic Functions</i></b>	<b>9</b>
	Table 2.1. ACB-S Cables and part numbers .....	10
<b>3</b>	<b><i>Connections to BSMS Keyboard</i></b>	<b>13</b>
<b>4</b>	<b><i>Connections to HPPR</i></b>	<b>17</b>
	Table 4.1. ACB-S HPPR signals. ....	17
<b>5</b>	<b><i>Additional Information</i></b>	<b>19</b>
<b>6</b>	<b><i>Appendix</i></b>	<b>21</b>



