

Bruker BioSpin

HPPR/2 •

Technical Manual

Version 005

The information in this manual may be altered without notice.

BRUKER BIOSPIN accepts no responsibility for actions taken as a result of use of this manual. BRUKER BIOSPIN accepts no liability for any mistakes contained in the manual, leading to coincidental damage, whether during installation or operation of the instrument. Unauthorized reproduction of manual contents, without written permission from the publishers, or translation into another language, either in full or in part, is forbidden.

This manual was written by

Ch.Schumacher (CSC)

A. Schwilch (SAR)

© January 24, 2008: Bruker Biospin AG

Fällanden, Switzerland

P/N: Z31559

DWG-No: 1271005

Contents

	Contents	3
1	Safety Instruction	7
1.1	Terms and symbols	7
1.2	Disclaimer	7
1.3	Emergency	7
1.4	Personnel safety	8
	Technically qualified personnel only	8
	Electrical safety	8
	Cleaning	8
2	HPPR/2	9
2.1	View	9
2.2	Overview	10
2.3	Features	10
2.4	Installation	11
	Connection Preamplifier/QNP Modules	11
2.5	Wiring	12
	DC-Wiring AVANCE I-III	12
	DC-Wiring DRX, DPX and DMX with RXC or RX22	13
	Tuning with DRX, DPX and DMX	13
	DC-Wiring DMX with HRD-16	14
	Accessories	14
	Parts List	15
2.6	HPPR/2 RF Power Supervision	16
	FAQs:	17
2.7	Abbreviations	20
3	Cover Module	21
3.1	Top Side	21
	Versions	21
	LED Description	22
	LCD and KEY Description	22
	Menu mode	22
	Menu Description	24
3.2	Rear Side	26
	Connector Rear Side	26
3.3	Functionality	27
	Topology	27
	Busses	28
	Power Supply and Monitoring	28
	Fuses	28
	Real-Time Pulse	29

	Microcontroller	29
	BIS	30
3.4	Connector Pinout	31
3.5	Test Issues	34
	General	34
	Power Fail Error	34
	Power supply protection / Fuse	34
	LED States	34
4	<i>Preamplifier Modules</i>	35
4.1	View	35
4.2	Measurement Modes	36
	1H, 3H, X-BB, 31P, 13C, 15N Module	36
	2H Module	37
	1H2H Module	38
	HPHP 19F/1H and XBB31P Module	40
	HPLNA 1H Module	41
	Interleave Increment (fast switching between different modes)	42
4.3	HPPR/2 Modules	43
	1H-LNA Module	44
	1H HPLNA MODULE	45
	2H Module	47
	1H2H Module	48
	31P Module	49
	13C Module	50
	15N Module	51
	XBB-19F 2HS Module 300-400	52
	XBB-19F 2HS Module 500-700	53
	XBB-31P 2HS Module 750-950	54
	HPHP/2 19F/1H Module	55
	HPHP/2 XBB31P Module	56
4.4	Technical Specifications	57
5	<i>QNP Module</i>	61
5.1	General	61
	QNP Functional Description	62
	Installation of the QNP Module	62
5.2	Functionality	63
	Topology	63
	IFB (Interface Board)	63
	Valve	64
	Connectors	64
6	<i>HPPR/2 Module Configurations</i>	67
6.1	Introduction	67
6.2	HPPR/2 Configurations for High Resolution	67
6.3	HPPR/2 Configurations for High Power	70
7	<i>MRI-INTERFACE MODULE</i>	73

7.1	Functionality	74
7.2	Connectors	75
7.3	Wiring	77
7.4	Technical Data	79
7.5	Installation	79
8	<i>MRI ACTIVE DETUNING MODULE</i>	81
8.1	Functionality	82
	RF-Section	82
	Coil Control Section	83
	Input Pulses	83
	PIN Driver Function	83
	Tune/Match Driver Function	84
	RGP Output Pulse	84
	Diagnostic Function	84
	Software Control	84
8.2	Connectors	85
8.3	Power Supply	87
8.4	RF-Wiring	87
8.5	Technical Data	88
	Coil Control Section	88
	RF-Section	89
8.6	Installation	89
9	<i>HPPR/2 UniTool</i>	91
9.1	Introduction	91
9.2	Identification of the firmware release	91
9.3	Download a new HPPR/2 firmware	91
	Download	91
	Error handling	92
	<i>Index</i>	93

Safety Instruction

1

Terms and symbols

1.1

WARNING: Disregarding of this may lead to personal injury.

NOTE: Hint for good operating practice.



Figure 1.1. High voltage!

Indicates dangerous voltage. Do not open any cover with this label!



Figure 1.2. Dangerous device!

Instruction manual symbol. It is necessary for the user to refer to the manual prior to the use of marked items.

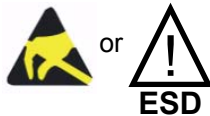

Figure 1.3. Electrostatic sensitive Device!

Observe precautions for handling.



Figure 1.4. Protective ground (earth) terminal

Used to identify any terminal which is connected to the external protective conductor for protection against electrical shock in case of fault.

Disclaimer

1.2

The following general safety precautions must be observed during all phases of operation and service of the HPPR/2 system. Failure to comply with these precautions or with specific warnings elsewhere in this manual violates safety standards of design, manufacture and intended use of the HPPR/2 system.

BRUKER assumes no liability for the customer's failure to comply with these requirements and is therefore not responsible or liable for any injury or damage that occurs as a consequence of non-approved manipulations on the HPPR/2 system.

Emergency

1.3

The mains switch in front of the AQS chassis serves as an EMERGENCY POWER OFF. It powers down the systems.

Personnel safety

1.4

Technically qualified personnel only

1.4.1

WARNING: Installation and servicing should only be done by BRUKER qualified personnel. Always disconnect power cable or switch off the system before servicing. Under certain conditions dangerous voltages may appear even with the power cable removed. To avoid injuries, always disconnect power and discharge circuits before touching them.

NOTE: Operating personnel must not remove HPPR/2 modules or the cover module except as described in this manual. Do not replace HPPR/2 units with system powered on.

User interface, system messages, and manuals require a good understanding of the English language.

Electrical safety

1.4.2

The HPPR/2 system's degree of protection against electrical hazard complies with IEC IP20, i.e. all electrical parts are protected against touching.

WARNING: All electrical connectors must be used as supplied by BRUKER. Do not substitute them by other types.

Cleaning

1.4.3

WARNING: Always switch power off and disconnect the power cable before cleaning. Never power on until all surfaces are completely dry.

Clean the outside of the HPPR/2 with a soft, lint-free cloth dampened in water. Do not use any detergent or other cleaning solvents.

Figure 2.1. HPPR/2 Standard Configuration with QNP Module



The High Performance Preamplifier version 2 (hereafter referred as HPPR/2) consists, in the basic configuration, of a 1H module, a XBB module, a 2H module and a Cover/Display module. The basic configuration may be updated later to a maximum of nine modules or even more with two HPPR/2 assemblies.

The preamplifier modules contain a Transmitter/Receiver switch including necessary high performance filters in the transmitter and probe paths, a rf preamplifier and an interface logic including a power supply and BIS (Bruker Information System). All preamplifier modules are 'Fourier capable'.

The display indicates on a LCD the operating status of the HPPR/2, e.g. what kind of modules are connected, what are their operating modes (observe, lock, wobble, decouple) and other information.

The status LEDs "ERROR", "READY", "SLEEP" and "COM" indicate the current state of the Cover Module. The "COM" LED shows real data communication with the HPPR/2. When the "SLEEP" LED is on, the microcontroller and oscillator in the Cover Module are switched off. This power down state is activated by the console during the acquisition phase, thus the Cover Module is not able to disturb the measurement.

The T-junction LEDs indicate during operation of the wobble mode the accuracy of probe tuning and matching and whether this must be corrected.

The individual modules, the power transmitter and the probe are connected with N-plugs and shielded cables. The BNC cable for the receiver signal leads from the rear Cover/Display unit to the FT and lock receiver in the console. A 36 wire MDR cable supplies all DC voltages for a maximum of three preamplifier modules. The cable also contains the required real time pulses (RGP_PA, LOCK_PP, INTERLEAVE_INCR) and a SBS-Bus (tty10) for command and data transfer between the console and the HPPR/2.

If there are used more than three preamplifier modules an additional power supply cable is needed.

Same RF technology as the classic HPPR

Ease of operation

Self configuration

Multiple HPPR/2 configuration, up to 2 HPPR/2

Modular arrangement, up to 9 modules per HPPR/2, even identical ones

Enhanced noise immunity (also Cover Module)

Enhanced display informations

Integration of external functional modules as ATMA, Cryoprobe and QNP

Installation

2.4

Connection Preamp/ QNP Modules

2.4.1

Figure 2.2. Right/ Wrong Module Connection

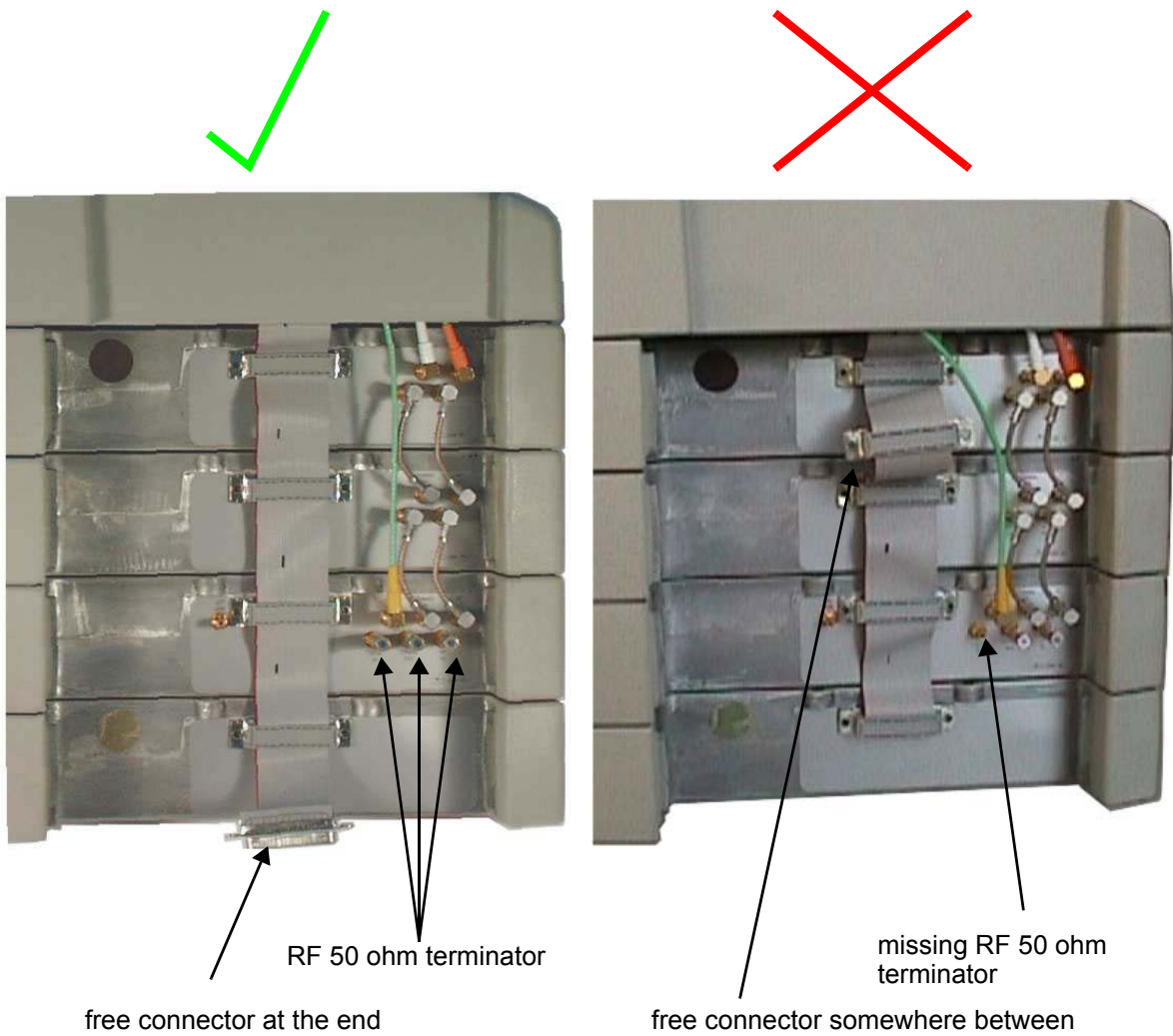
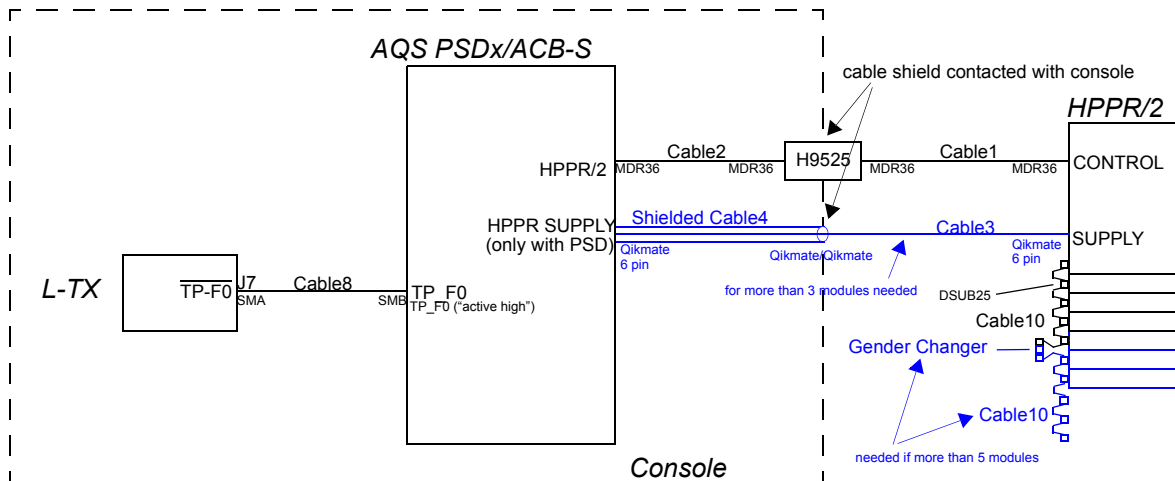
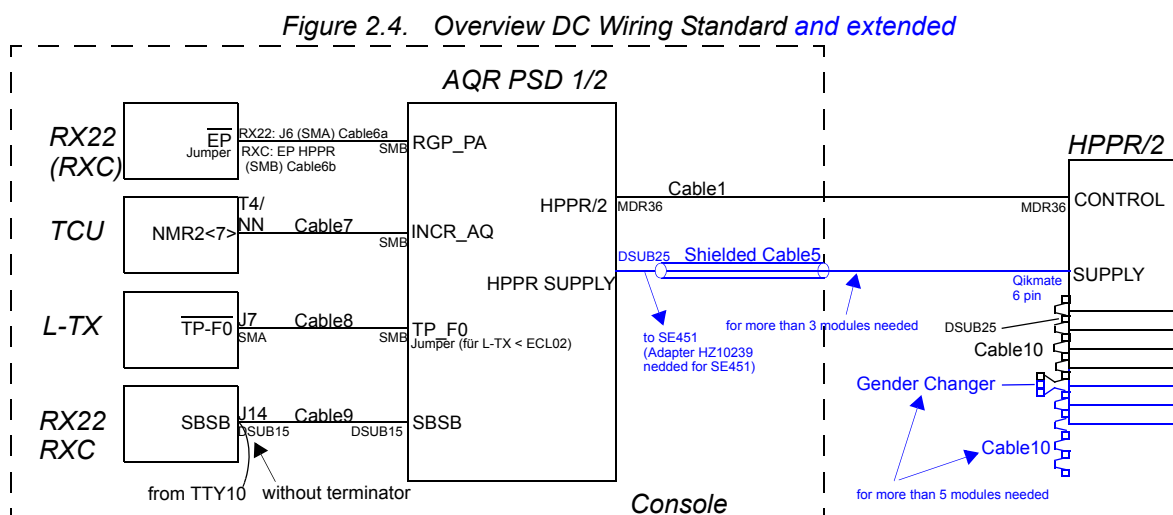

Figure 2.3. Overview DC Wiring Standard and extended



Remark:

- The Extended version (more than three preamplifier modules) is only possible in conjunction with a AQS PSD board, because there is no supply plug (6 pin Qikmate plug) on the ACB-S board.
- The polarity of TP_F0 cannot be configured on the AQS PSD/ACB-S board. Since it is adjusted to "active high", all L-TX can be operated.



Remarks:

- The AQR PSD basically expects low active pulses (RGP_PA, INCR_AQ, TP_F0). Therefore it can only be operated with RXC starting from ECL01.
- The default setting for the TP_F0 pulse is set to “high active” in all BSMS L-TX boards and set to “low active” in all AQR PSD boards. With BSMS L-TX ECL02 and later, the TP_F0 pulse polarity can be set using the BSMS Service Tool. With AQR PSD the TP_F0 pulse polarity can be set with the jumper JU1. Therefore the TP_F0 polarity has to be set to “high active” on the AQR PSD board or has to be changed to “low active” on the BSMS L-TX board (only possible with BSMS L-TX ECL02 and later).
- It is an AQR PSD needed (1 or 2 depending on AQR type ,AQR PSD/1 for AQR Chassis and AQR PSD/2 for AQR/P Chassis) with ECL01 or later.
- The cableset H9714 contains all the necessary cables for an upgrade of a DRX, DMX, or DPX to HPPR/2.
- The cableset H9714/1 contains all the necessary cables for an upgrade of a DRX or DMX with RXC (and SE451) to HPPR/2.
- For more than 5 modules, the HPPR+9V fuse on the AQR (PSB1) must be increased to 2.5A (Part no. 2255).

The tuning signal from a DRX or DPX console is too strong for the HPPR/2. To prevent saturation a 10dB attenuator must be fixed at the HPPR/2 tuning signal input. The attenuator (part no. 90289) is part of the cable set AQR-HPPR/2 RX22 (H9714). For a DMX console with SE451 a 13dB attenuator (85435) is necessary which is part of H9714 var1.

Figure 2.5. Overview DC Wiring Standard and Extended

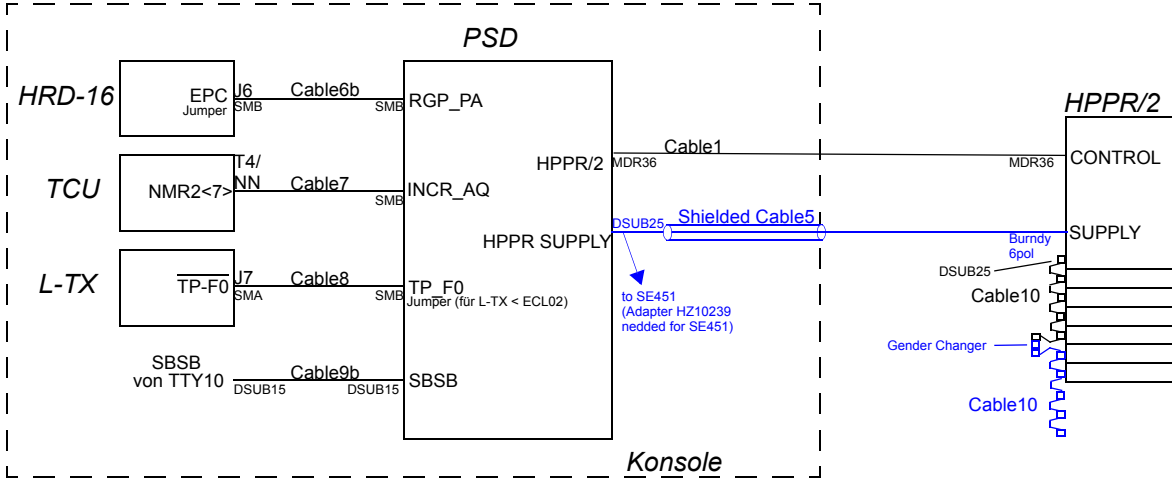

- The cableset H9714/2 contains all the necessary cables for an upgrade of a DRX or DMX with HRD-16 to HPPR/2.

Accessories

Figure 2.6. Overview Cable Accessories for HPPR/2 DC Wiring

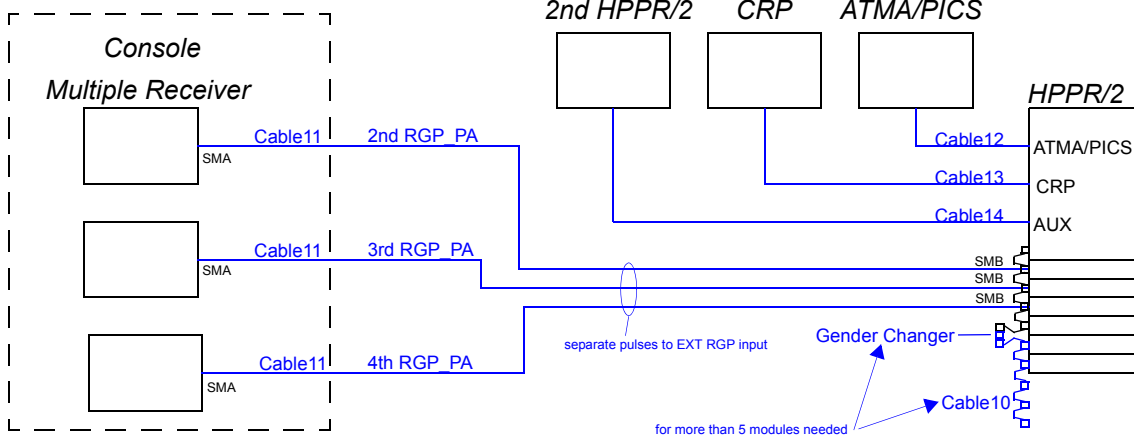

Table 2.1. Cable List

Id	P/N	Len	Description
Cable1	HZ10174	7m	IEEE1284 C-C (MDR 36 pin 1:1), AWG28
Cable2	HZ10175	2m	IEEE1284 C-C (MDR 36 pin 1:1), AWG28
Cable3	HZ10110/A	7m	Qikmate 6 pin / Qikmate 6 pin, shielded, 1.5mm ²
Cable4	HZ10109/A	1m	Qikmate 6 pin / Qikmate 6 pin, shielded, 1.5mm ²
Cable5	HZ10197	8.5m	Qikmate 6 pin / DSUB25, shielded, 1.5mm ²
Cable6a	HZ10195	1.5m	RG316 or RG178, SMA/SMB (for RX22)
Cable6b	HZ10193	1.5m	RG316 or RG178, SMB/SMB (for RXC)
Cable7	HZ10196	2.2m	RG316 or RG178, BY /SMB
Cable8	HZ10194	2.2m	RG316 or RG178, SMA/SMB
Cable9a	HZ04459	0.45m	DSUB25m/DSUB25f, shielded, 1:1
Cable9b	HZ04460	2m	DSUB25m/DSUB25f, shielded, 1:1
Cable10	Z14091	0.29m	CABLE FLK 25P Preamp-Bus
Cable11	tbd	7.5m	RG316 or RG178, SMA/SMB
Cable12	Z14361	2.2m	CABLE RD 5P HPPR/2 <-> ATMA/PICS
Cable13	Z14362	1.8m	CABLE RD 10P HPPR/2 <-> CRP
Cable14	tbd	1.5m	RJ45 Kabel 1:1, shielded

Table 2.2. Various Parts

Id	P/N	Description
Gender Changer	47020	GENDER CHANGER M/M 25 POL
Adapter for SE451	HZ10239	CABLE 25P ADAP AQR PSD HPPR/2

Introduction

Some of the recently introduced HPPR/2 modules (1H2H modules and HPLNA 1H) have a built in, calibrated RF power limit detection capability. This power limit detection capability is used to supervise the power applied to the probe (calibrated and referenced at the probe connector of the HPPR/2 module), but also to protect the appropriate HPPR/2 module against too much applied power.

The transmission of RF power through the HPPR/2 module is being monitored autonomously (supervision is enabled after power up) and in case of exceeding power, the emergency stop signal will be activated. After a latency of about 2-3us all RF pulses and RF sources will be stopped.

RF Power

In order to avoid too much power to be applied to the probe, the power limit detection thresholds of the HPPR/2 modules for continuous (CW) and peak (PK) power are set according to the probe connected to the HPPR/2.

For each probe connected to the HPPR/2 COVER MODULE the PICS entries of that probe are read out by the firmware of the HPPR/2. The values for continuous but also peak power are extracted from the '\$PChan' group for each nucleus. Afterwards, the threshold values for the power limit detection are set for each nucleus (if power limit detection is available) according to the probe power values.

To avoid an emergency stop too close at the probe power limits, a 2 dB respectively a 3 dB margin is added for the power limit detection thresholds.

The following diagram shows the characteristics (and the pulse length dependency) of the RF power detection.

Figure 2.7. Threshold for RF power versus pulse length

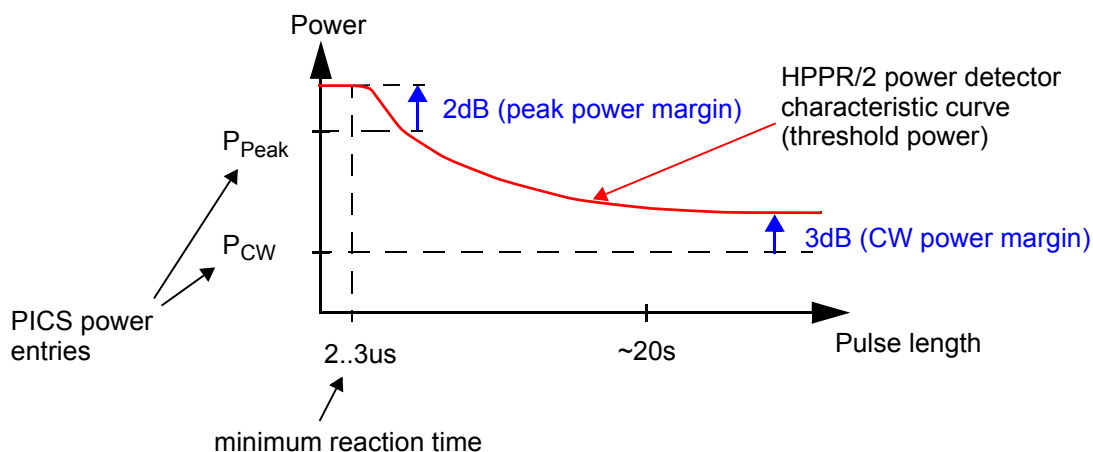

The threshold value for CW pulses can be understood as the RF power of pulses of about 20s. The power limit threshold value for pulses between a few microseconds (peak power) and the very long pulses (CW power) behaves like described above (red curve).

The setting of the threshold values can be monitored on the HPPR/2 COVER module display (see following figures).

Figure 2.8. Threshold power display

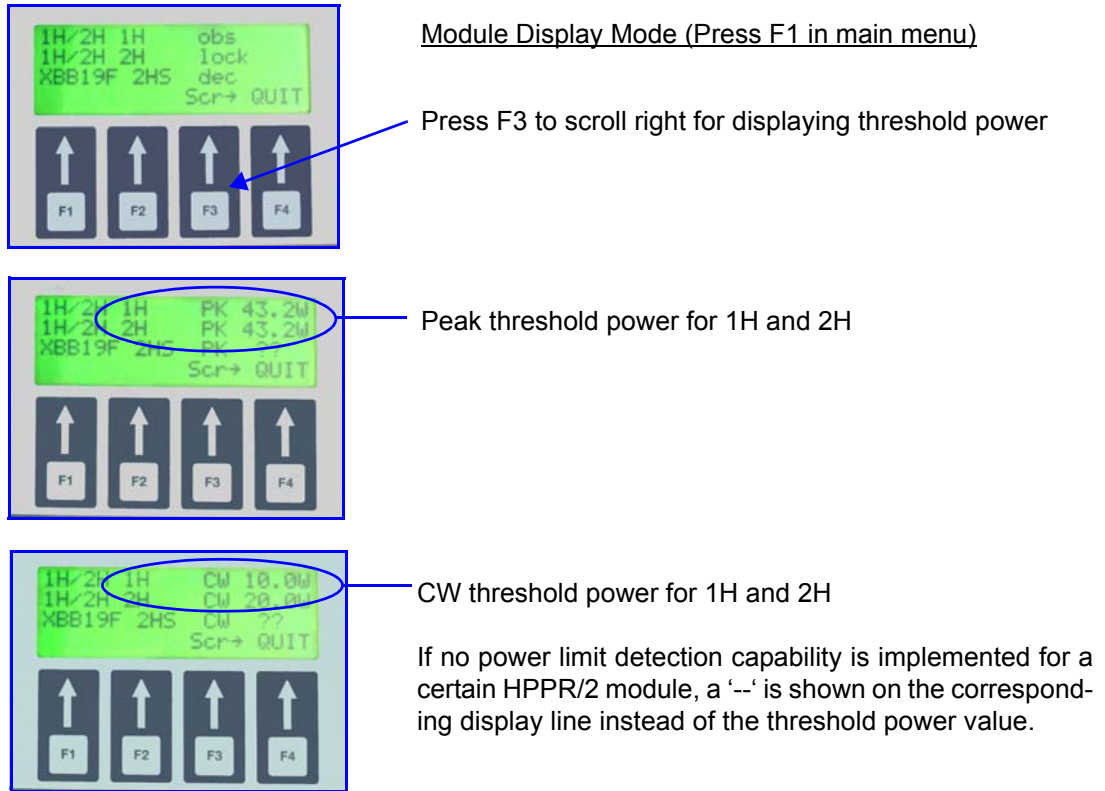

FAQs:

2.6.1

Which HPPR/2 modules are equipped with a power limit detection?

Today (January 2008) the following modules are equipped with a power limit detection:

- Z003958 HPPR/2 1H2H MODULE 300, ECL>=3
- Z003959 HPPR/2 1H2H MODULE 400, ECL>=3
- all frequencies HPPR/2 1H HPLNA MODULE xxx
- all frequencies HPPR/2 19F HPLNA MODULE xxx
- all frequencies HPPR/2 1H HPLNA MODULE xxx MRI

In future new modules will be published by EC only.

How can I see if the supervision is activated?

The supervision can only be disabled by UniTool until next power up. After power up the supervision is always enabled automatically (default).

For the supervision you need at least firmware version **HPPRAJ.hex** for the 1H2H modules and **HPPRAN.hex** for the HPLNA1H modules or higher.

What happens in case of missing power entries in the PICS?

If a value is missing in the ‚\$PChan‘ group of the PICS, the maximum power rating of the corresponding HPPR/2 module will be set.

What happens in case of „incorrect“ or „corrupt“ (non numerical) power entries of the probe PICS?

The maximum power rating of the corresponding HPPR/2 module will be set.

What happens in case of higher rating of the probe than the HPPR/2 module?

The maximum power rating of the corresponding HPPR/2 module will be set.

What happens if the probe contains no PICS?

All limits of the HPPR/2 modules will be set to its corresponding maximum power ratings.

How can I check whether the supervision is available for a certain HPPR/2 module?

Check on the HPPR/2 COVER display as described in **Figure 2.8**.

How can I check whether the supervision is available for a certain nucleus by using the AQS integrated preamplifiers?

Check the \$HpprFunc group of the module BIS. The version of the group must be at least 2.3 and the sixth entry must be set to „1“.

\$HpprFunc, 2.3, FreqRange, Shortname, RefType, LowGain, RefMeter, AutoPowDet#



Version of the \$HPPFunc group must be at least 2.3



0: has no automatic power detection
1: has an automatic power detection

The \$HpprFunc group is valid for all HPPR/2 modules and not only for the AQS integrated preamplifiers.

When are the power limit detection threshold values set?

All threshold values are set after power up and in addition before setting the HPPR/2 COVER into the sleep mode. In that way it is possible to set the threshold values according to the probe PICS. The only situation, which can not be handled is, when the probe PICS has been changed and RF power is being applied without setting the preamplifier into the sleep mode.

How can the supervision be deactivated?

Following example shows, how the supervision for a certain module can be disabled. This can be done for any module, having the power limit detection feature.

Start UniTool for HPPR and select:

[P] Preamplifier Module

[5] 1H/2H 1H

[F] Set Overload Detect

(1=disable, 0=enable)

ADM	Active Detuning Module
ATMA	Automatic Tuning and Matching Accessory
BIS	Bruker Information System
CRP	Cryo Probe
CW	Continuos Wave
HPPR/2	High Performance Preamplifier version 2
HPLNA	High Power low Noise Amplifier
IFB	HPPR/2 Interface Board (interface from the module to the Preamp-Bus)
INCR_AQ	see INTERLEAVE_INCR
INTERLEAVE_INCR	Interleave Increment Pulse
I2C	I2C bus (two wire single master bus)
PLD	Programmable Logic Device
LCD	Liquid Crystal Display
LOCK_PP	Lock Protection Pulse
MDR	Mini Delta Ribbon connector (e.g. from 3M)
PICS	Probe Identification System
QNP	Quadro Nucleus Probe
RGP_HPPR	Receiver Gating Pulse for HPPR
RGP_PA	see RGP_HPPR
SBSB	Serial Bruker Spectrospin Bus (RS485 Bus)
TP_F0	see LOCK_PP

Figure 3.1. Cover Module top view



The HPPR/2 Cover module is available in two different versions:

- HPPR/2 COVER MODULE Z003356
- HPPR/2 COVER MODULE MRI Z103945

The MRI version powers off the entire LCD display during acquisition due to minimize electromagnetic interferences.

The LEDs indicate the current state of the HPPR/2 and the tuning/matching information from the probe (see also [3.5.4](#)).

Table 3.1. LED description

Label	Description
MATCHING LED TUNING LED	This display only becomes active when the HPPR/2 is in Tuning/Matching mode and indicates the quality of the Tuning/Matching balance.
ERROR LED	Monitors HPPR/2 error state.
READY LED	Monitors microcontroller ready state.
SLEEP LED	Monitors microcontroller power down state.
COM LED	Monitors HPPR/2 communication on SBS or AUX bus.

Table 3.2. LCD and KEY description

Label	Description
LCD	The LCD is used to show user menus and some other useful information (e.g. module list, tuning/matching channel, error message).
KEY [F1] ... [F3]	This keys are used to navigate in menu and to execute user functions. Key function during menu handling: [F1] : scroll clockwise through the menu. (see figure ...) [F2] : scroll counter clockwise through the menu. [F3] : select this menu ('ok').
KEY [F4]	Pressing this key always quits the current menu or function. NOTE: Pressing [F1] and [F4] simultaneously will always result in returning to the idle menu.

Notation

Expressions in quotation marks and in bold italic letters (e.g., '4. LCD illumination') represent what is shown on the HPPR/2 display. Expressions in square brackets and in bold capital italic letters (e.g., **[F1]**) indicate keys.

General

The menu mode of the HPPR/2 gives a direct access to different HPPR/2 functions.

Figure 3.2. .HPPR/2 menu mode



After: EN_Tom / jca
Datum: 23. Oktober 2006

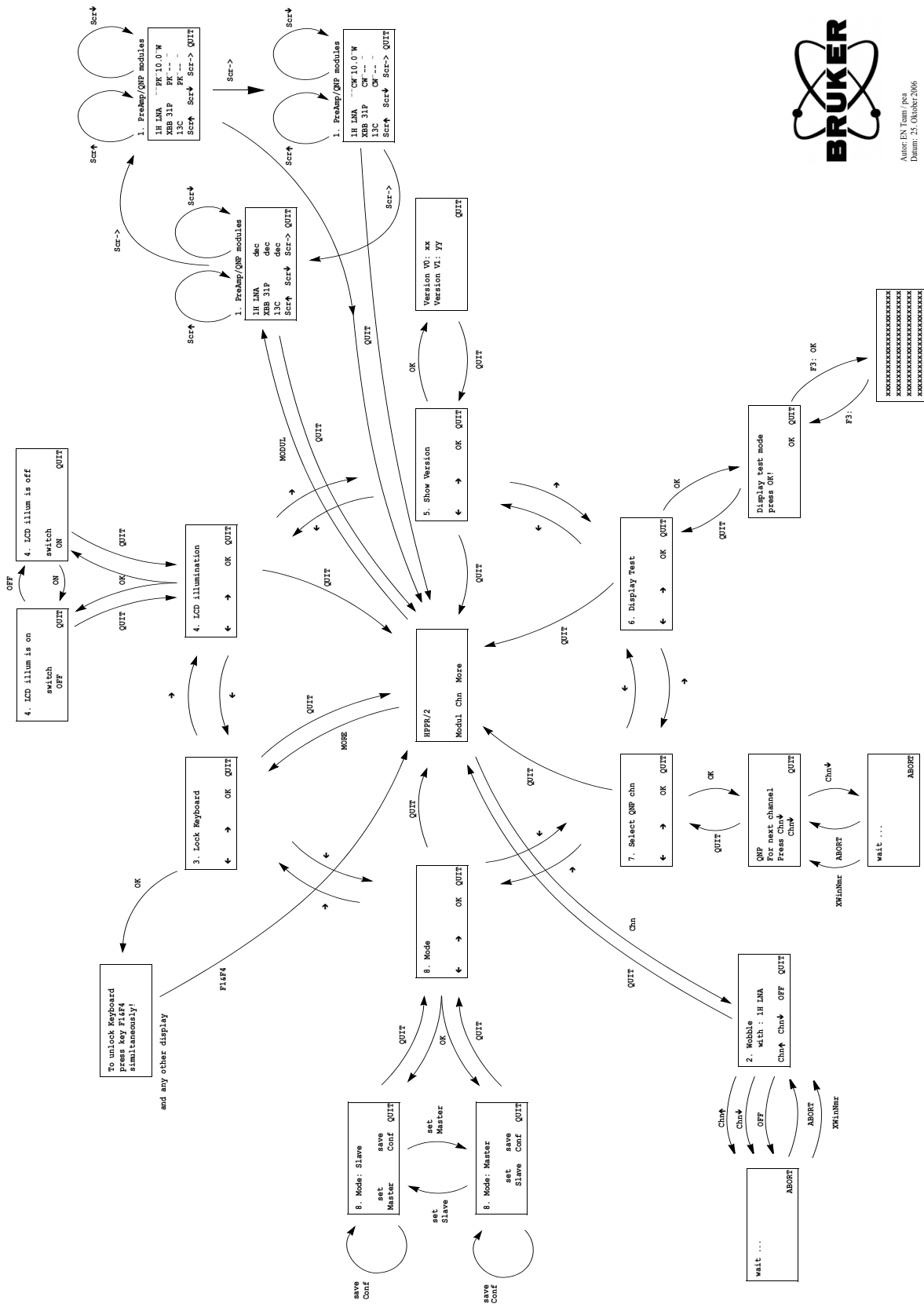

The menu navigation works very easy and is similar to other already known user interfaces like the BSMS keyboard. Therefore it won't be further explained than in **Figure 3.2.**

The main menu is composed of the following submenus: '1. **MODUL**' (list of all preamp modules), '2. **CHN**' (Channel) and '**MORE**'. 'More' is sub-divided into six further menu points: '3. **Lock Keyboard**', '4. **LCD illumination**', '5. **Show Version**', '6. **Display Test**', '7. **Select QNP chn**', '8. **Mode**'.

Each of these submenus have several functions, which are described below for HPPR firmware version "AJ" or later (file: e.g. hppran.hex).

Menu Description

3.1.5

Idle Menu

After power-up and confirming 'power fail' the HPPR/2 display shows the idle menu.

Pressing **[F1]** or **[F2]** leads directly into the menu function "**1. MODUL**" or "**2. CHN**". Pressing **[F3]** '**MORE**' leads to further menu points (3 ... 8).

'1. MODUL'

This function lists all preamp modules and their actual states actually connected to the current HPPR/2. The following states are possible:

Table 3.3. Module state

state	Description
'dec'	Decouple mode (default), module is not used for observe or lock and is therefore always protected from transmitting pulses.
'obs'	Observe mode, this module is used as observe channel. The protection of the module is dependent on the real time pulse "RGP_HPPR".
'lock'	Lock mode, this module is used as lock channel. The protection of the module is dependent on the real time pulse "LOCK_PP".
'wobb'	Tuning/Matching mode, this channel can be tuned and matched.
'crp ...'	Cryo probe mode, can be combined with all states described above (dec, obs, lock or wobb).
'fwd pwr'	The forward power from the reflectometer is routed to the RF out of the HPPR/2 (only implemented in HPLNA modules)
'refl pwr'	The reflected power from the reflectometer is routed to the RF out of the HPPR/2 (only implemented in HPLNA modules)
'pwr err'	Power error, a power error has occurred on this module. Check the connection to the module and the preamplifier module itself.
'stop'	Emergency stop, an emergency stop signal has occurred on this module.

'2. CHN'

This menu point shows the current wobble channel if available. It allows to change the channel for Tuning/Matching.

'MORE'

This menu point leads to the following menu points:

'3. Lock Keyboard'

Entering this function locks the keys on the HPPR/2 display (useful during a long experiment). **'To unlock press key F1&F4 simultaneously'** appears on the display and all other key-combinations are disabled. To exit this mode, press **[F1]** and **[F4]** simultaneously.

'4. LCD Illumination'

Enables the user to switch on or off the LCD illumination. After power-up the illumination is always switched on.

'5. Show Version'

'V0 = ...' shows the current hardware version of the Preamplifier Control Board. This is the control board with the microcontroller (see [3.3.1](#)) which is a part of the Cover Module.

'V1 = ...' shows the current hardware version of the Display Board which is another part of the Cover Module.

'6. Display Test'

Tests the LCD and all LED's.

'7. Select QNP channel'

Allows to change the QNP channel if QNP module is connected.

'8. Mode'

The current HPPR/2 Mode is shown: Master or Slave. Master Mode is the default setting from the factory. The other mode can be set with **[F2]** **'set ...'** and saved with **[F3]** **'save Conf'**. Saving the Mode will take a few seconds.

In standard configuration (one HPPR/2) the HPPR/2 has always to be set in master mode. In configuration with two HPPR/2 only the master HPPR/2 has to be set in master mode. The other/second HPPR/2 has to be set in slave mode.

After changing the mode, the new configuration has to be saved with the function **'save Conf'**. After that the HPPR/2 has to be re-initialized (power-up or init command with unitool). From now on the HPPR/2 is working in the selected mode.

'save Conf' saves the configuration to the FLASH PROM in the HPPR/2 Cover Module.

The HPPR/2 mode can also be set by unitool. Note that the unitool address will change when changing the mode. Therefore UniTool has to be restarted with the new address.

Figure 3.3. Cover Module rear view



Connector Rear Side

Table 3.4. Connectors on the rear side

Label	Connector Type	Description
CONTROL	MDR 36 pin	Control signals (SBSB, real time pulses, emergency stop) and power supply for three preamplifier modules.
AUX POWER SUPPLY	Qikmate 6 pin	Auxiliary power supply for more than three preamplifier modules.
CRP	RJ45	Connection to Cryo Probe.
ATMA/PICS	RJ45	Connection to ATMA or PICS.
AUX	RJ45	Auxiliary connection to another HPPR/2.

Functionality

3.3

Topology

3.3.1

Figure 3.4. HPPR/2 Cover Module Block Diagram

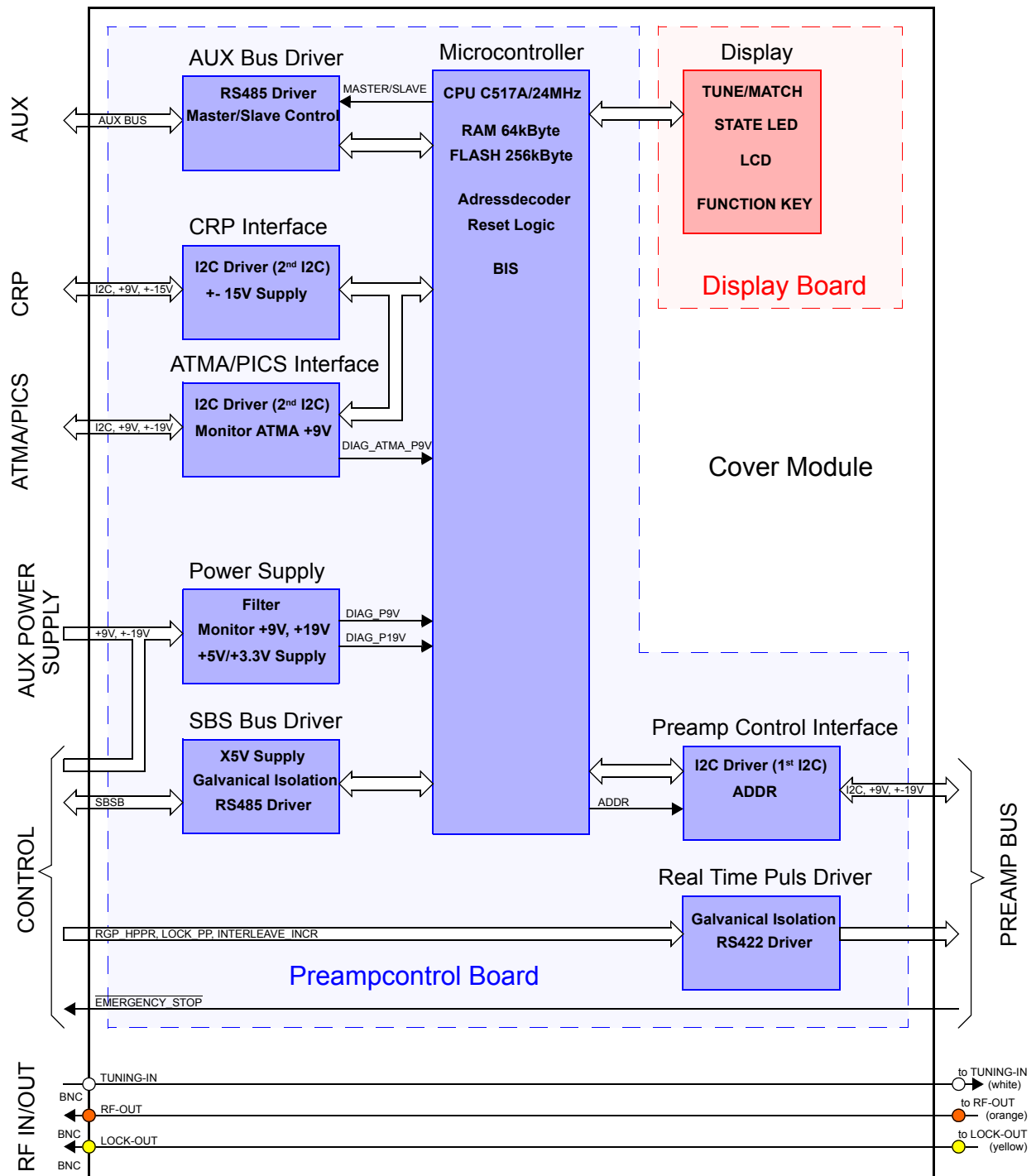

Each HPPR/2 Cover Module has 4 independent busses :

- SBSB, controlling HPPR/2 in master mode
- AUX bus, controlling HPPR/2 in slave mode
- I2C bus 1, controlling external devices as ATMA/PICS and CRP
- I2C bus 2, controlling internal devices (preamplifier modules, QNP Module)

All voltages supplied from the console are filtered on the HPPR/2 Cover Module.

The HPPR/2 Cover Module with ECL 01 or later is monitoring the +19V, +9V and ATMA/PICS +9V. In following case the HPPR/2 will display an error message:

Table 3.5. Power Supply Error Cause

Error Cause	Error Code	Description
+9V < 7.8V or +19V < 17.8V	90	The power supply +9V or +19V is too low. Check the power supply in the console (AQR or AQS) and use a special power supply cable to HPPR/2.
+9V > 10V or +19V > 20.5V	91	The power supply +9V or +19V is too high. Check the power supply in the console (AQR or AQS).
ATMA +9V < 7.6V	93	The connected ATMA or PICS might be defect or there is a wrong device connected to the ATMA/PICS connector.
-19V		No power monitoring

The connectors "AUX", "ATMA/PCIS" and "CRP" are protected against short circuit. There are resetable fuses ("Multifuse") built-in for this protection. In case of a fault condition (e.g. short circuit at the ATMA/PICS connector), excessive current flows through the "Multifuse" and heats the fuse material. As the fuse has a very large non-linear Positive Temperature Coefficient (PTC) this will increase the fuse resistance sharply.

The fuse will stay "hot", remaining in this high resistance as long as the power is applied. The fuse will remain latched, providing continuous protection, until the fault is cleared and the power is removed.

! *All power supplies contained in the Preamp-Bus are only protected with the HPPR/2 power supply fuses (see PSM1-3,5 or PSB1-3 depending on the console type).*

Real-Time Pulse**3.3.5**

All pulses are galvanically isolated by fast opto couplers on the HPPR/2. After that, they are driven by a RS422 driver to the preamplifier modules. The pulse delay from the pulse driver, opto couplers and transmission line to the preamplifier module is less than 300 ns.

The polarity of the real time pulses can't be modified on the HPPR/2 Cover Module.

There are following three real time pulses:

1. RGP_HPPR, Receiver Gating Pulse HPPR (also known as RGP_PA)
2. LOCK_PP, Lock Protection Pulse (also known as TP_F0)
3. INTERLEAVE_INCR, Interleave Increment (also known as INCR_AQ)

See example in chapter **4.2.6 "Interleave Increment (fast switching between different modes)" on page 42**

Microcontroller**3.3.6**

Before starting an experiment the microcontroller is set into power down state. After a successful processing and acquisition the controller can be woken up by the SBSB_WUP~ signal to handle system requests or new instrument initialization.

The microcontroller system boots after each reset. While the controller boots, the HPPR/2 does not serve the serial interface. Any data received on the SBS bus is ignored. The boot time must be considered by any application and testing software.

The microcontroller system consists of a Infineon C517A / 24 MHz microcontroller, a 128K * 8 Bit Static RAM, a 4MB paged FLASH PROM and a 24 MHz clock generator. The external bus interface of the controller consists of an 8-bit data bus, a 16-bit address bus and several control lines. The address latch enable signal (ALE) is used to demultiplex address and data of port 0. The program memory is accessed by the program store enable signal (PSEN~) every second machine cycle. The read or write strobe (RD~, WR~) is used to access the external data memory.

An address decoder controls the microcontroller program and data memory accesses. It enables/disables (depending on the address and control signals) different devices. The controller boots normally from one page of the FLASH memory and runs its application software from other pages. The PSEC~ control signal is asserted by the controller while it downloads more recent application software or stores later BIS or configuration data. This maps the FLASH memory into the data segment and the RAM into code segment. The controller accesses now the RAM as if it was a nonvolatile code memory. Therefore program instructions are copied from the boot partition of the FLASH memory to the RAM before starting the download procedure.

The boot software programmed in the test department is not field programmable and is protected from unwanted program and erase operations.

More recent application software can be loaded using the BRUKER UniTool.

The HPPR/2 Cover Module BIS data contains information about production data, ECL, hardware type and display type.

BIS information is provided by the internal microcontroller and can be read using UniTool commands.

Table 3.6. CONTROL connector: Mini Delta Ribbon 36 pin (female)

Signal Name	Pin No.	Remark
HPPR +19V	1,2	HPPR/2 power supply
HPPR -19V	19,20	
HPPR +9V	3 - 8	
GND	13, 15, 21-26, 31, 33	
EMERGENCY_STOP	32	Emergency Stop signal
$\overline{\text{EMERGENCY_STOP}}$	14	
RGP_HPPR	18	Gating Pulse for HPPR
$\overline{\text{RG P_HPPR}}$	36	
LOCK_PP	17	Lock Protection Pulse
$\overline{\text{LOCK_PP}}$	35	
INTERLEAVE_INCR	16	Interleave Increment Pulse
$\overline{\text{INTERLEAVE_INCR}}$	34	
RxD+	10	SBSB signals and power supply
RxD-	28	
TxD+	11	
TxD-	29	
$\overline{\text{WUP}}$	12	
VRS	9	
XGND	27, 30	

Table 3.7. AUX Power Supply connector: Qikmate 6 pin (female)

Signal Name	Pin No.	Remark
HPPR +19V	6 ^a	HPPR/2 power supply
HPPR -19V	3	
HPPR +9V	2	
GND	1, 4, 5	

a) In an older manual version, pin 2 and 6 were wrong

Table 3.8. AUX connector: RJ45 8 pin (female)

Signal Name	Pin No.	Remark
AUX TxD+	1	AUX bus RS485 transmitter (master mode) or receiver (slave mode) signals.
AUX TxD-	2	
AUX RxD+	3	AUX bus RS485 receiver (master mode) or transmitter (slave mode) signals.
AUX RxD-	4	
reserved	5	Reserved for power supply, not connected.
$\overline{\text{AUX WUP}}$	6	Wake up signal (master mode = out; slave mode = in)
GND	7, 8	Ground

Table 3.9. CRP connector: RJ45 8 pin (female)

Signal Name	Pin No.	Remark
EN I2C	2	I2C bus clock, data and enable signal.
SCL	3	
SDA	4	
CRP P15V	1	Power supply for Cryo Probe.
CRP N15V	5	
GND	6, 7, 8	

Table 3.10. ATMA/PICS connector: RJ45 8 pin (female)

Signal Name	Pin No.	Remark
EN I2C	2	I2C bus clock, data and enable signal.
SCL	3	
SDA	4	
ATMA/PICS +19V	1	Power supply for ATMA or PICS.
ATMA/PICS -19V	5	
ATMA/PICS +9V	6	
GND	7, 8	

Table 3.11. PREAMP BUS connector: DSUB 25 pin

Signal Name	Pin No.	Remark
HPPR +19V	11	HPPR/2 power supply
HPPR -19V	1	
HPPR +9V	5, 6, 7	
GND	2, 3, 9, 16, 19, 20, 22	
EMERGENCY_STOP	4	Emergency Stop signal
RGP_HPPR	23	Receiver Gating Pulse
$\overline{\text{RG P_HPPR}}$	10	
LOCK_PP	8	Lock Protection Pulse
$\overline{\text{LOCK_PP}}$	21	
INTERLEAVE_INCR	24	Interlave Increment Pulse
$\overline{\text{INTERLEAVE_INCR}}$	12	
SCL	15	I2C bus clock and data signal
SDA	14	
ADDR1	17	Daisy chain for addressing the modules.
ADDR2	18	
	13	Not used
TMS	25	Reserved for PLD

Test Issues

3.5

General

3.5.1

To avoid damage to the electronics the HPPR/2 Cover Module must not be opened in the field. The internal microcontroller supervises the operation of the board and detects serious malfunction. All fuses applied in HPPR/2 Cover Module are resetable and therefore have not to be changed.

Status information and error messages are sent to the workstation and displayed on the HPPR/2 Cover Module LCD.

Power Fail Error

3.5.2

After an ordinary power-up, a firmware-download or a power-breakdown the HPPR/2 creates a **“power fail error”** with error code 13. This informs the spectrometer, that the system has not yet been initialized. The error code has no further meaning for the user of the spectrometer.

Power supply protection / Fuse







3.5.3

The power supply for the “ATMA/PICS”, “CRP” and “AUX” connector are protected against short circuit with resetable fuses or short circuit resistant power supplies. In case of a fault, the fault has to be cleared and the power supply has to be removed (see also [3.3.4](#)).

LED States

3.5.4

Table 3.12. LED States

ERROR	READY	SLEEP	Description
off	off	off	Power supply not on or HPPR/2 is still booting
off	off	on 	Sleep mode (oscillator switched off)
blinking  fast	on 	off	HPPR/2 is in boot mode, no application software is running or a download is in process.
on 	on 	off	Error state, the error must be acknowledged by the master or user.
off	on 	off	Normal operation mode

Preamplifier Modules

4

View

4.1

Figure 4.1. Preamp Module Connectors (open module)

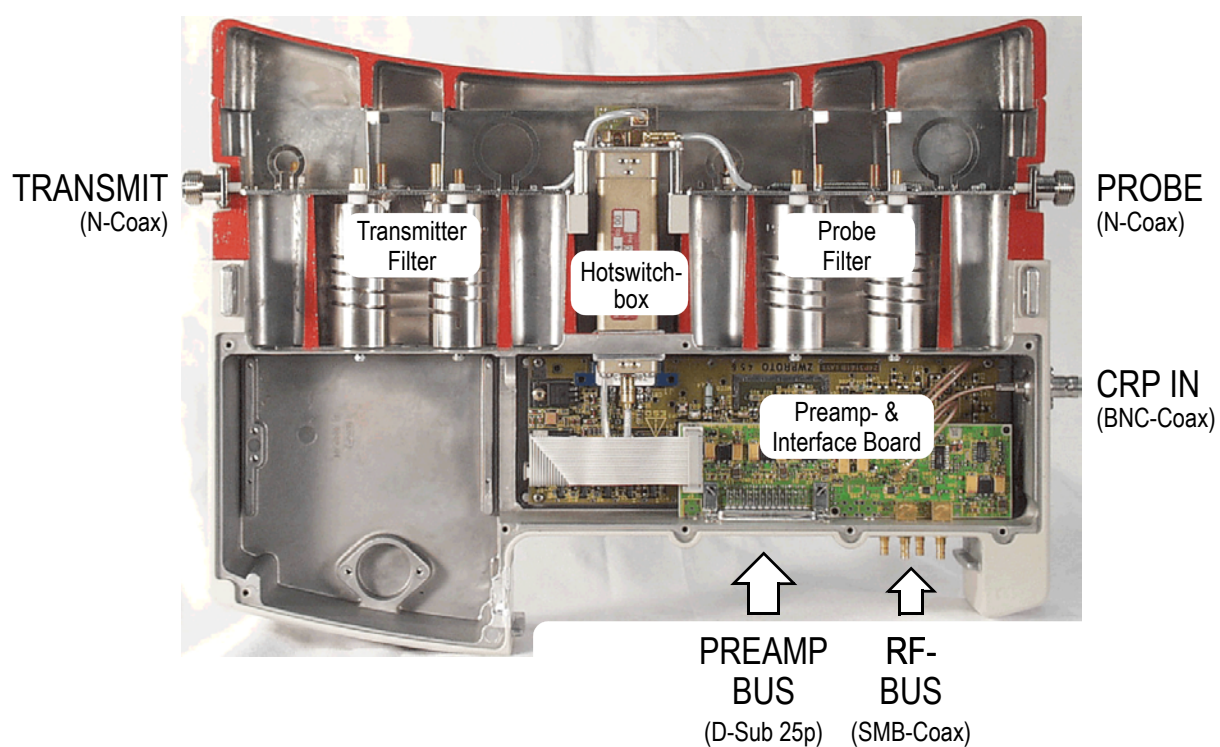

Figure 4.2. Measurement modes 1H,3H, X-BB, 13C, 15N- Module

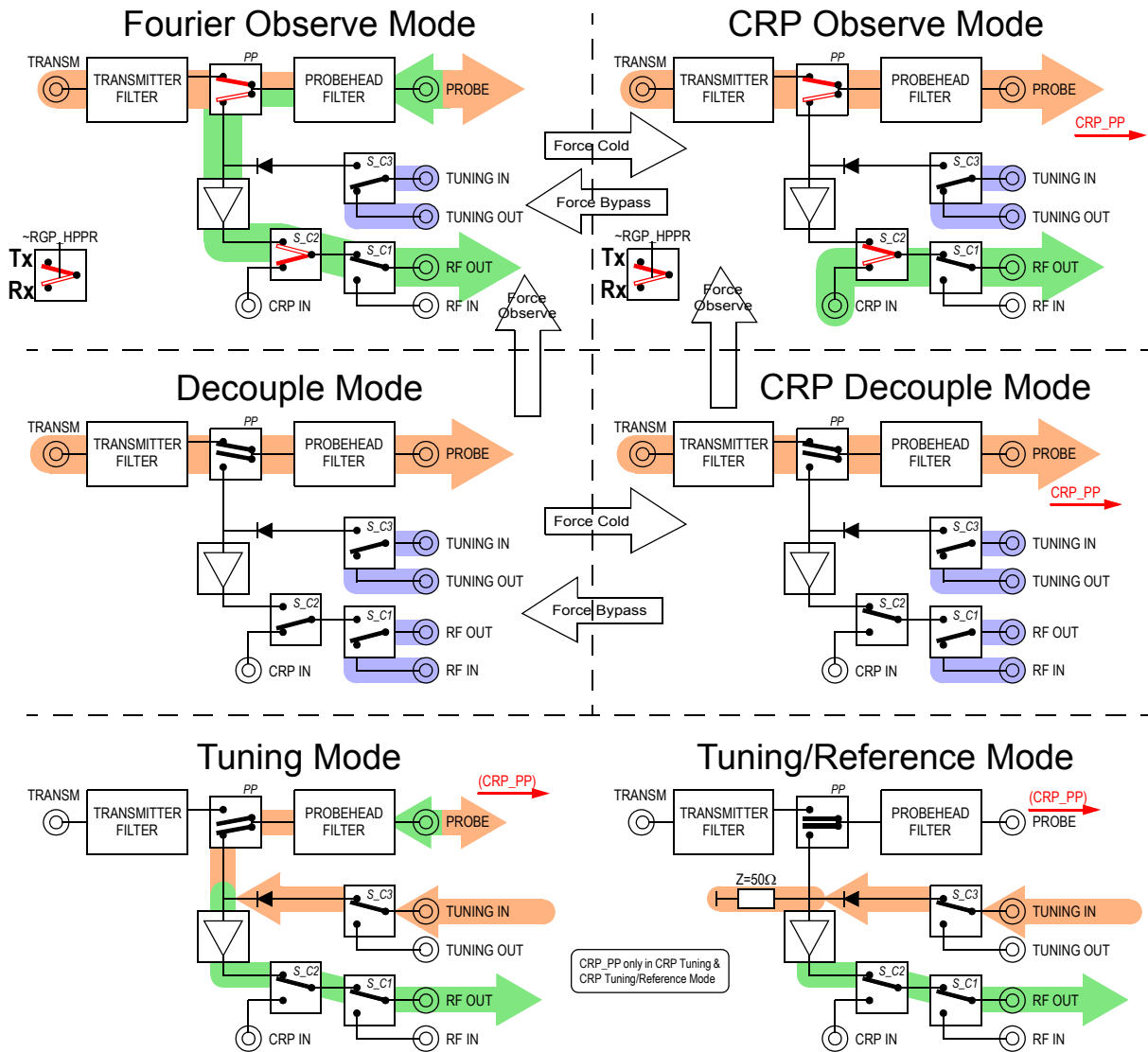

Figure 4.3. Measurement modes 2H, 19F Module

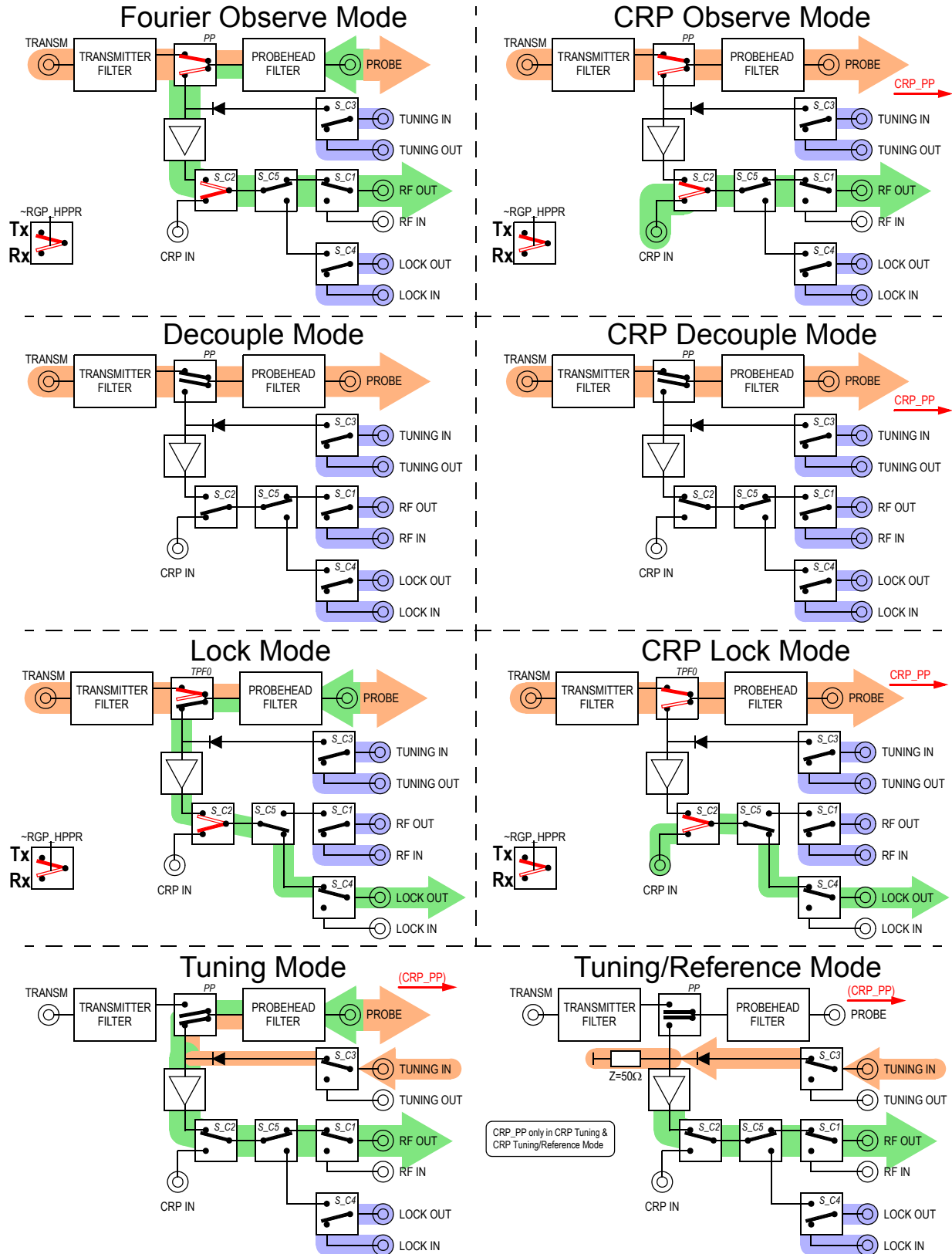

Figure 4.4. Measurement modes 1H2H Module (OBS, DEC, LOCK)

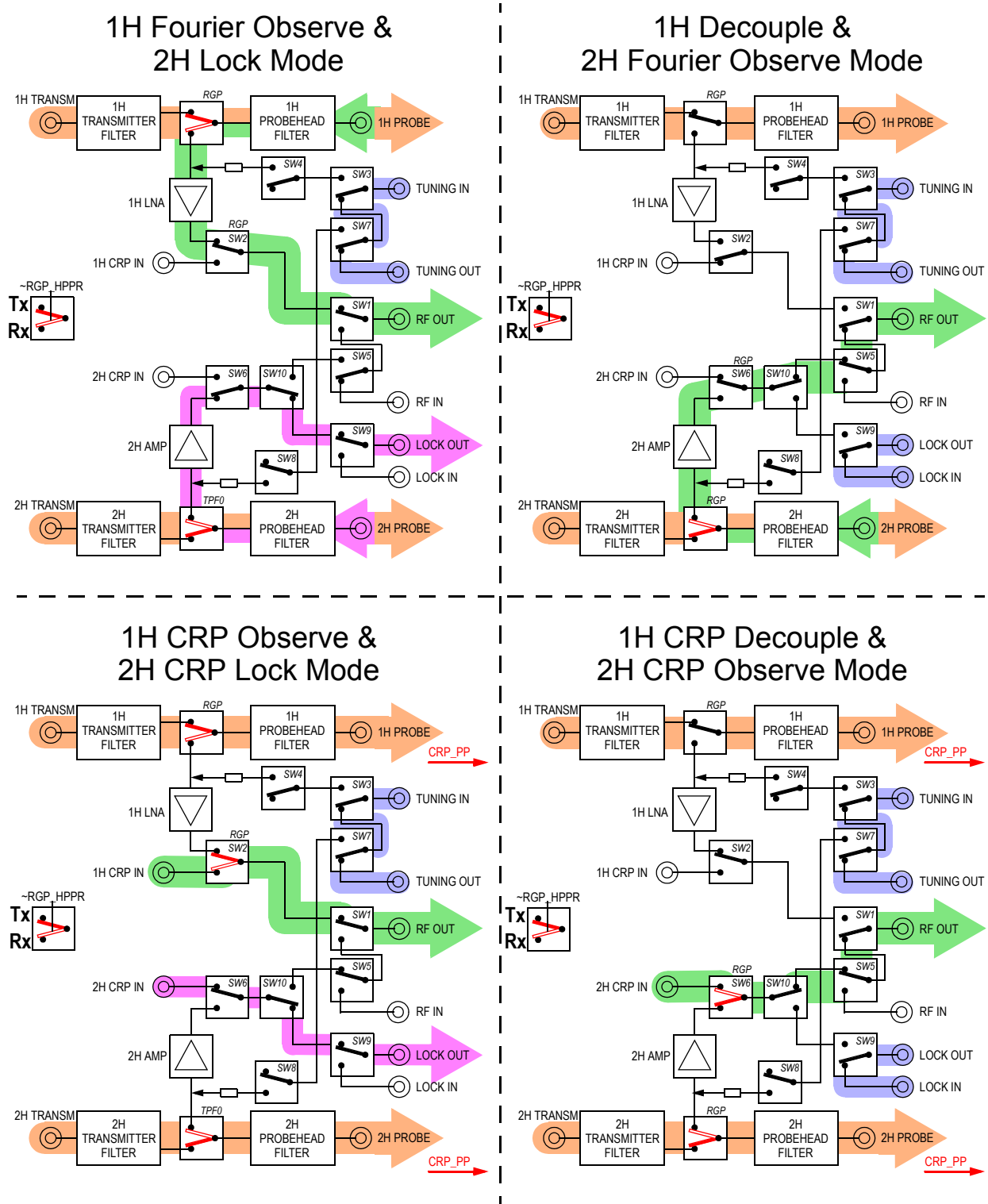

Figure 4.5. Measurement modes 1H2H Module (TUN, TUN/REF)

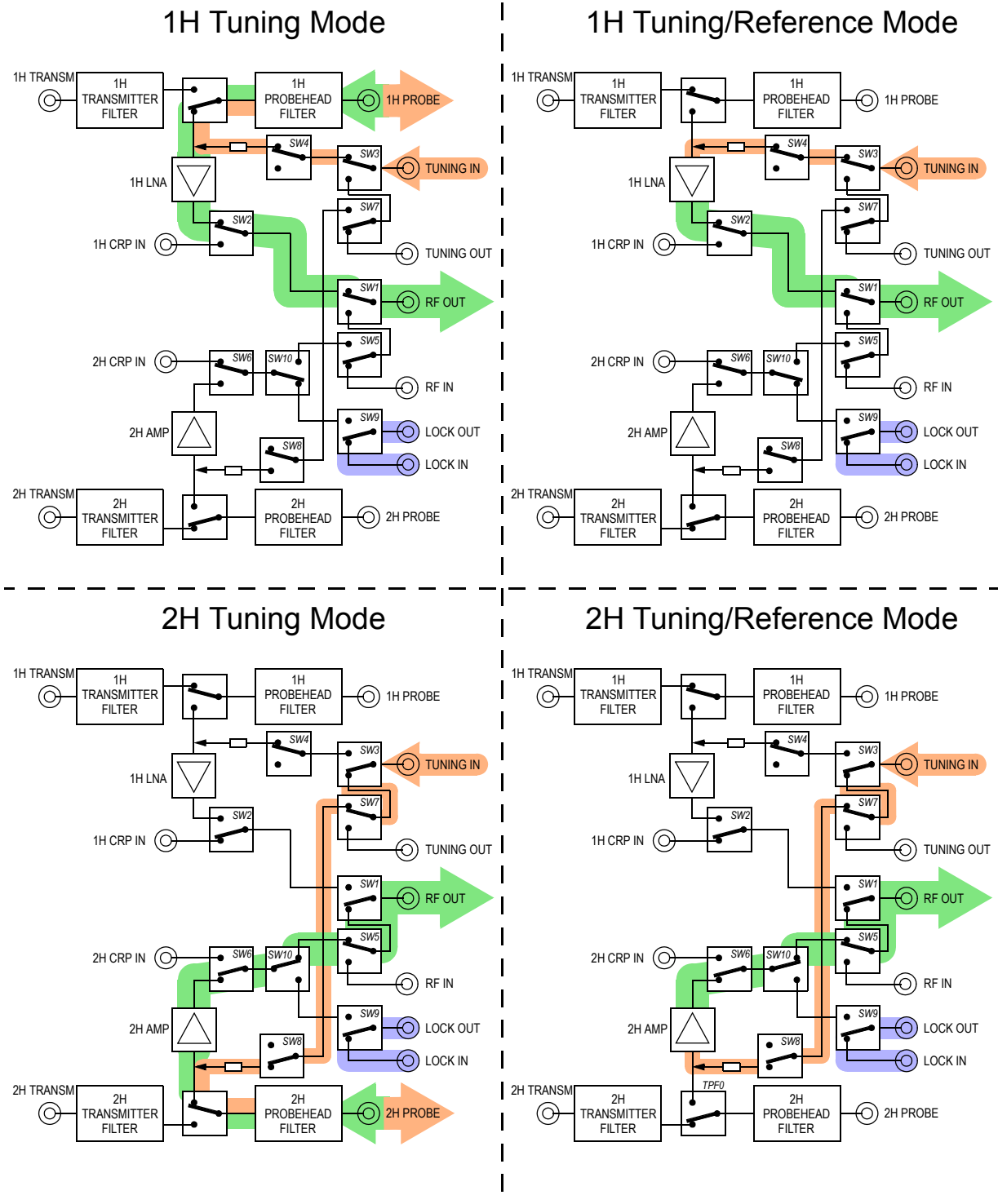
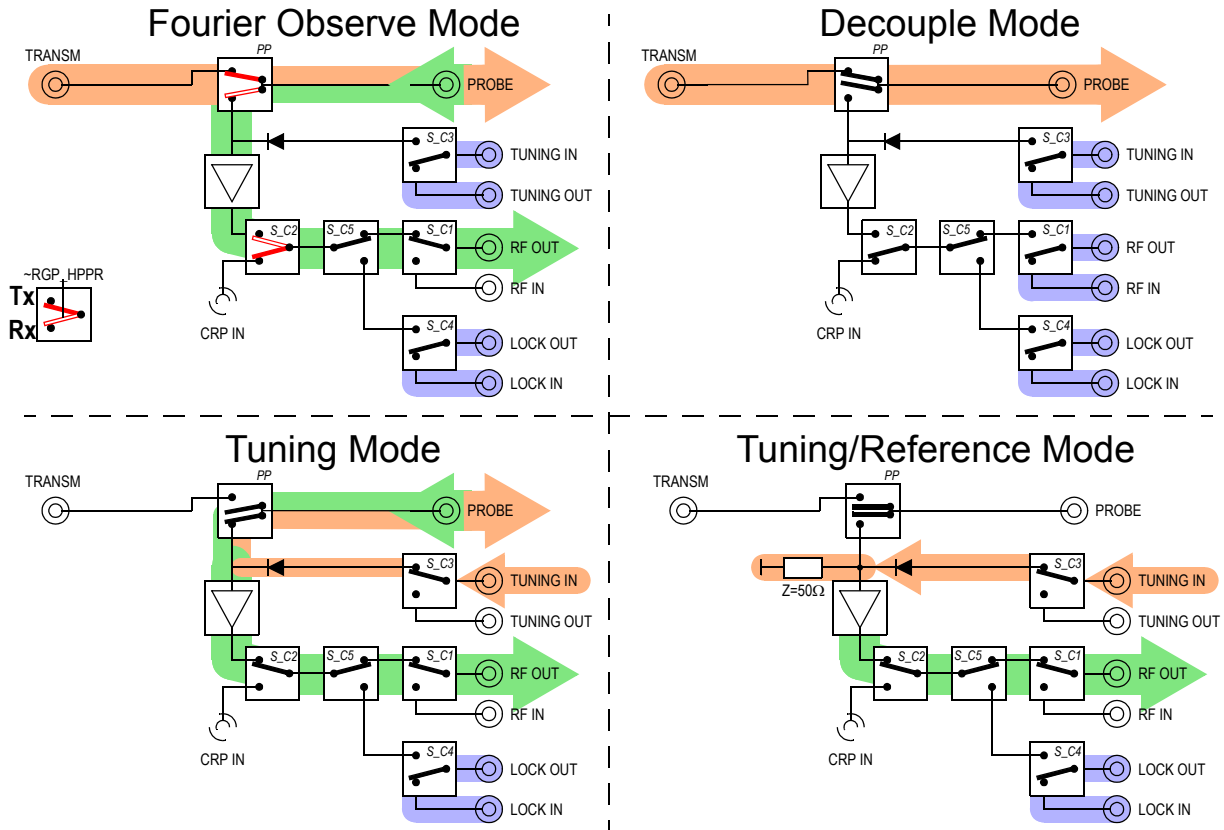
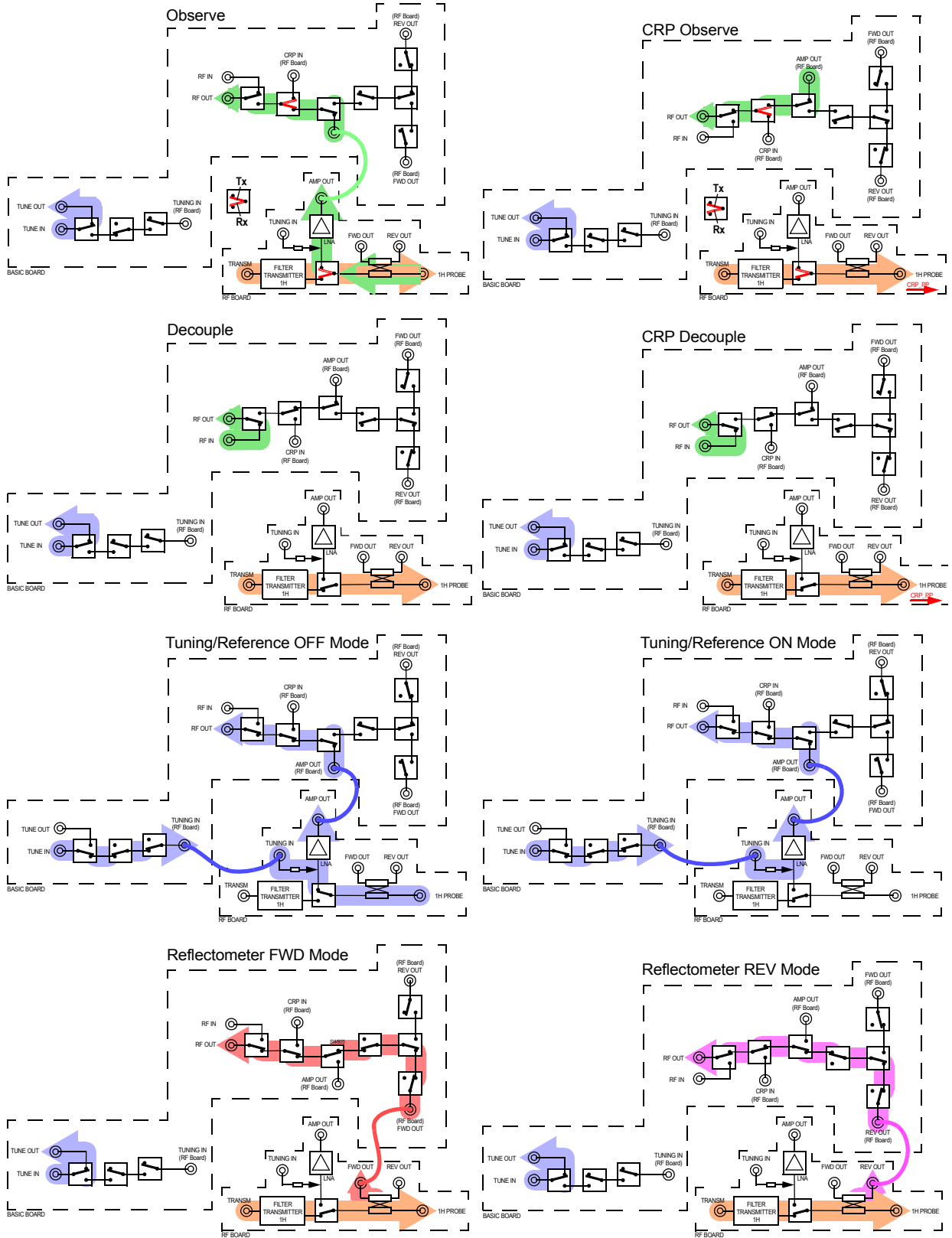

Figure 4.6. Measurement modes HPHP 19F/1H and HPHP XBB31P



Figur 4.7. Measurement modes HPLNA 1H



Example:

After routing the '2H' module in 'edsp', TopSpin 1.3 pl 2 sets the four modes of the corresponding '2H' module for a CRP system as follows:

- mode 0 : crp lock
- mode 1 : crp decouple
- mode 2 : reset counter
- mode 3 : <any mode> (not used)

This short pulseprogram switches between 'crp lock' and 'crp decouple' mode. 'crp decouple' is set for half a second (see timing diagram below).

```

1 ze
2 d1
  10u setrtp1|6
  500m setrtp1^6

  10u setrtp1|6
  10u setrtp1^6

  go=2 ph31
  30m wr #0
exit

ph1=0
ph31=0
    
```

setrtp1: 1 is the logical number of the observe channel. It is determined by the TopSpin command 'edsp'.

|6 , ^6: Set ~INTERLEAVE_INCR pulse (bit 6) on AQS backplane to low resp. to high.

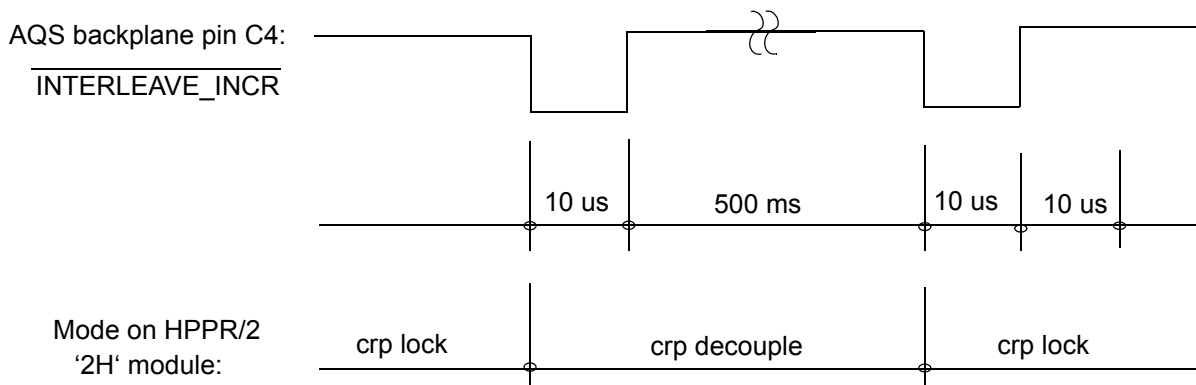

The figures in this section contain the block diagrams of the following modules:

- HPPR/2 1H-LNA Module
- HPPR/2 1H HPLNA Module
- HPPR/2 2H Module
- HPPR/2 1H2H Module
- HPPR/2 31P Module
- HPPR/2 13C Module
- HPPR/2 15N Module
- HPPR/2 XBB-19F 2HS Module 300-400
- HPPR/2 XBB-19F 2HS Module 500-700
- HPPR/2 XBB-31P 2HS Module 750-950
- HPPR/2 XBB-31P 2HS Module
- HPHP/2 19F/1H Module
- HPHP/2 XBB31P Module

The figures show all internal subsections and individual boards with their interconnections. Signal names, connector pin numbers and connector types are also noted.

Figur 4.9. 1H HPLNA Module Block Diagram

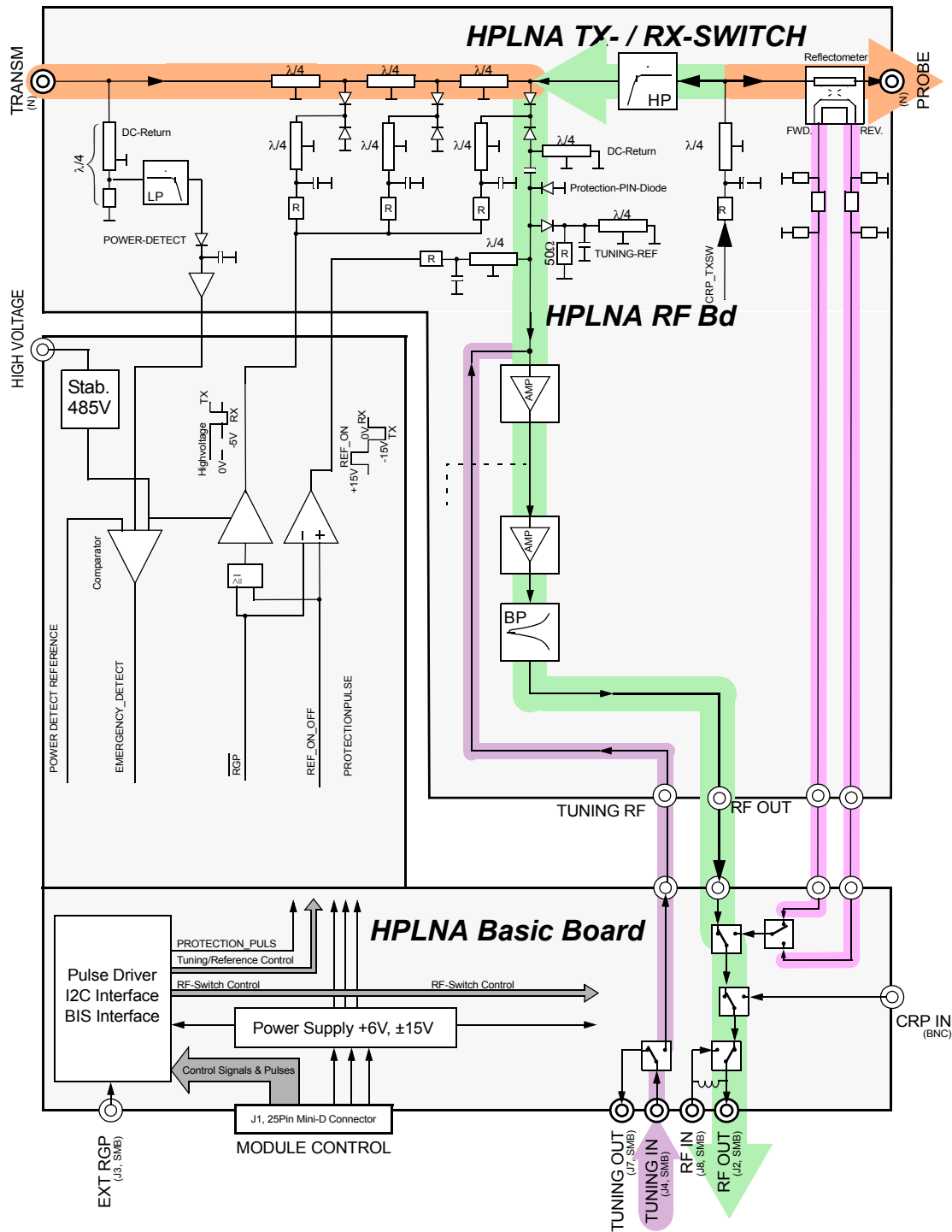

1H HPLNA Features

The recently introduced 1H HPLNA family brings the LNA technology to high power applications.

This new preamplifier family is a combination of high power and LNA technology, therefore the new preamplifiers are specifically suited for all MRI and Solids applications but reasonable for mixed spectrometers with high resolution and high power capability as well. The modules are available in two versions, for imaging (MRI) and for solids applications.

The HPLNA modules have the following features:

- High power capability, up to 4kW for peak power and 400W continuous power.
- High linear active biased transmitter switch.
- Low noise figure (1dB).
- Enhanced linearity ($P_{1dB} \geq 18\text{dBm}$ for 28.5dB gain).
- Integrated X nuclei stop filter (up to 31P) for solids versions.
- Optimized LNA input match (better than -25dB return loss) for the MRI versions.
- Integrated software controllable REFLECTOMETER for optimal probe matching under power conditions. The reflectometer output signals (according to forward or reflected power) can be routed (up to now under UniTool control) directly to the receiver and can be displayed in the same way as an acquisition signal. The directivity of the reflectometer is better than 25dB.
- The HPLNA is prepared for interfacing a CryoProbe as well.
- PICS dependant power supervision for exceeding peak and cw power (similar to HPPR/2 1H2H Module 300 and 400).
- Further implemented diagnostics and supervision to protect the module against damage (minimal receiving time $\geq 1\mu\text{s}$, minimal transmitting time $\geq 2\mu\text{s}$, maximal T/R switching frequency $\leq 80\text{kHz}$, power supply supervision).
- Calibrated internal 50Ohm reference for accurate matching and tuning (always run CF after installation).
- The HPLNA module must be supplied by an additional power supply module (Z104783 AQS PSM HPLNA). The power supply is prepared to fit to the right of the PSM5 inside the AQS or AQS/2 or AQS/3 chassis.
- Note: If there is no slot available on the back of the AQS chassis and the system is equipped with a 24TE wide PSM3, the PSM3 can be replaced by the new 12TE wide PSM5 (refer to ECH3341).
- The power supply cable (Z104842), necessary to connect the HPLNA module, is available in a standard length of 8m.

Caution:

The HPLNA power supply delivers up to 500V, therefore the installation at customer site is only allowed to be carried out by Bruker qualified personnel in compliance with the local safety regulations.



Figure 4.10. 2H Module Block Diagram

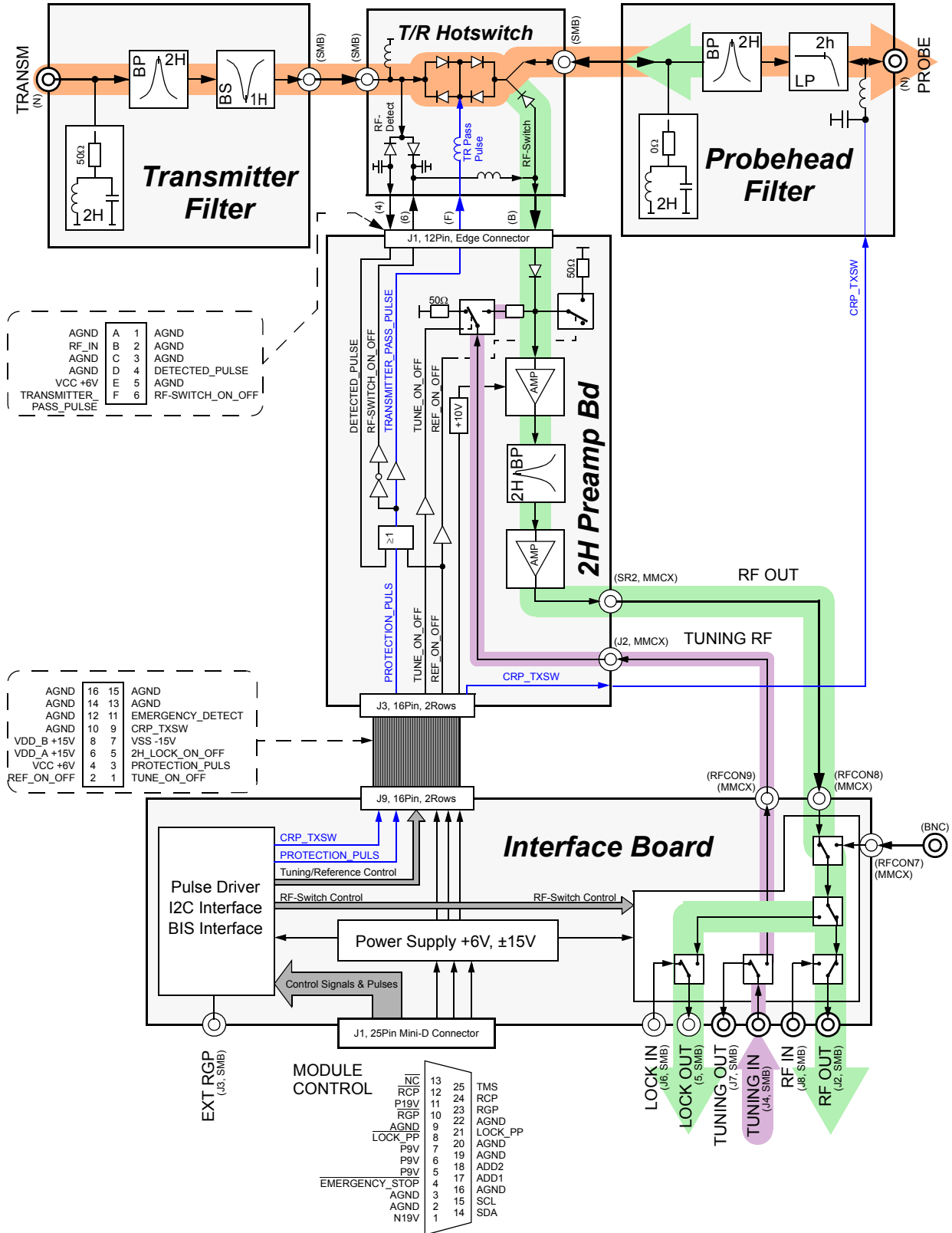

Figure 4.11. 1H/2H Module Block Diagram

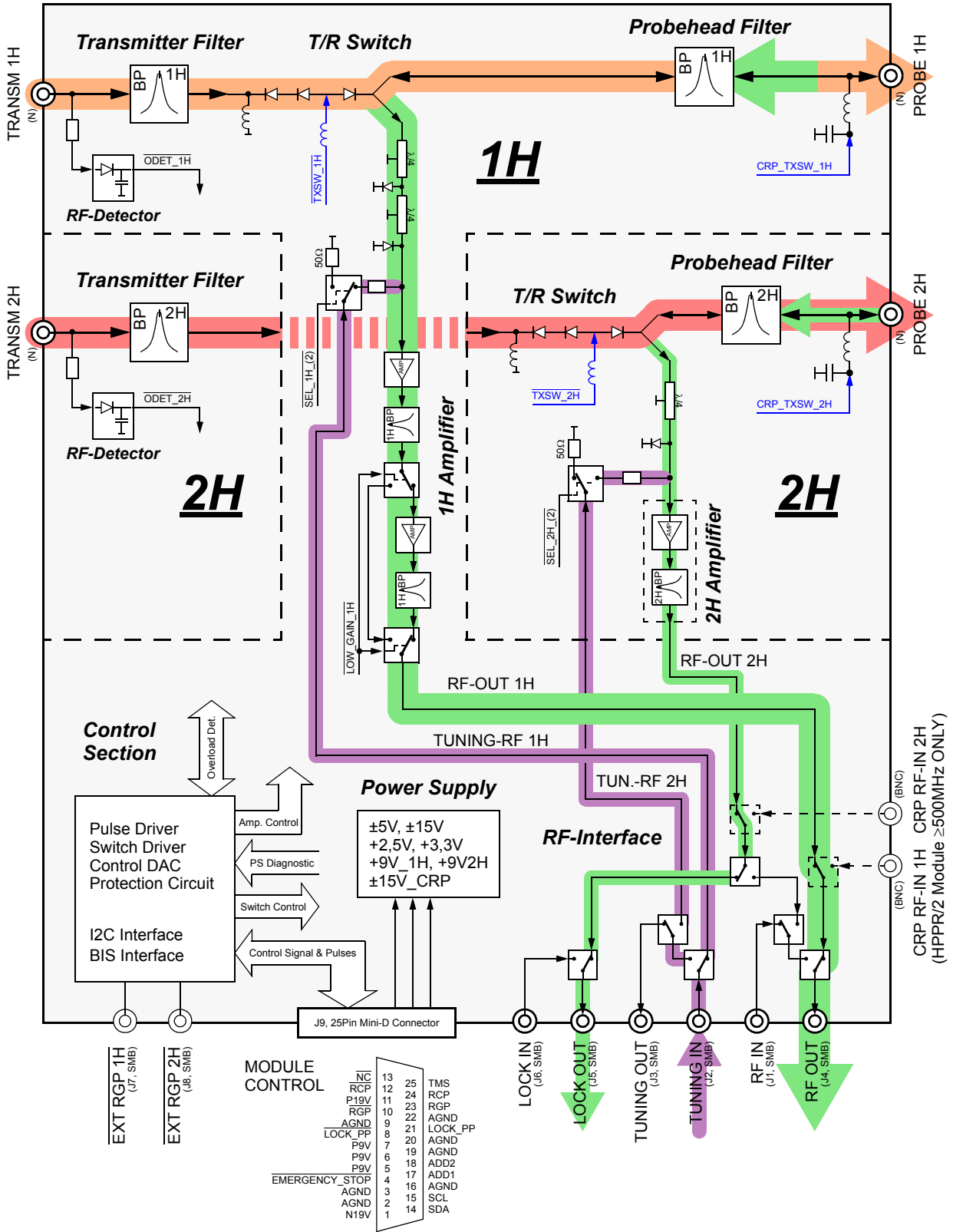

Figure 4.12. 31P Module Block Diagram

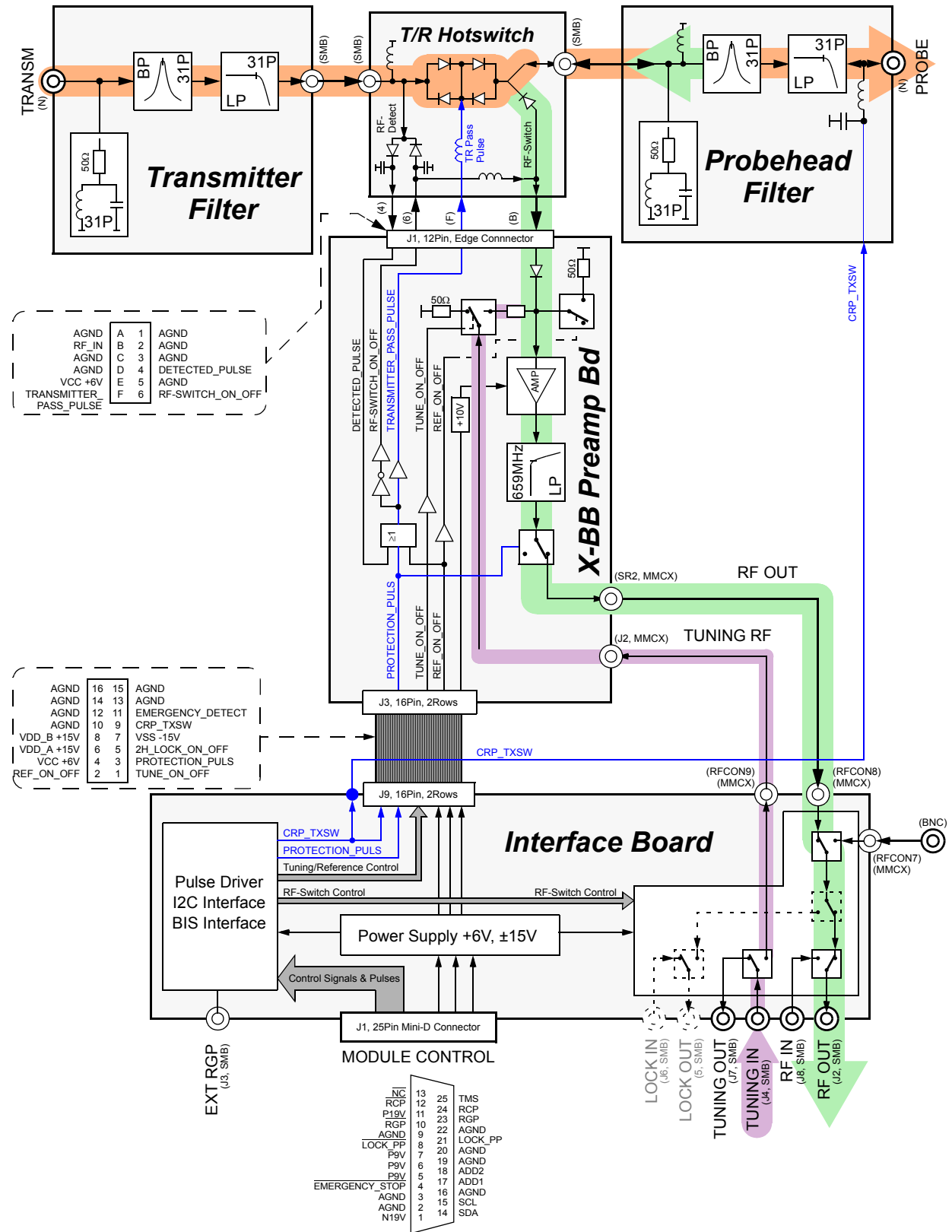

Figure 4.13. 13C Module Block Diagram

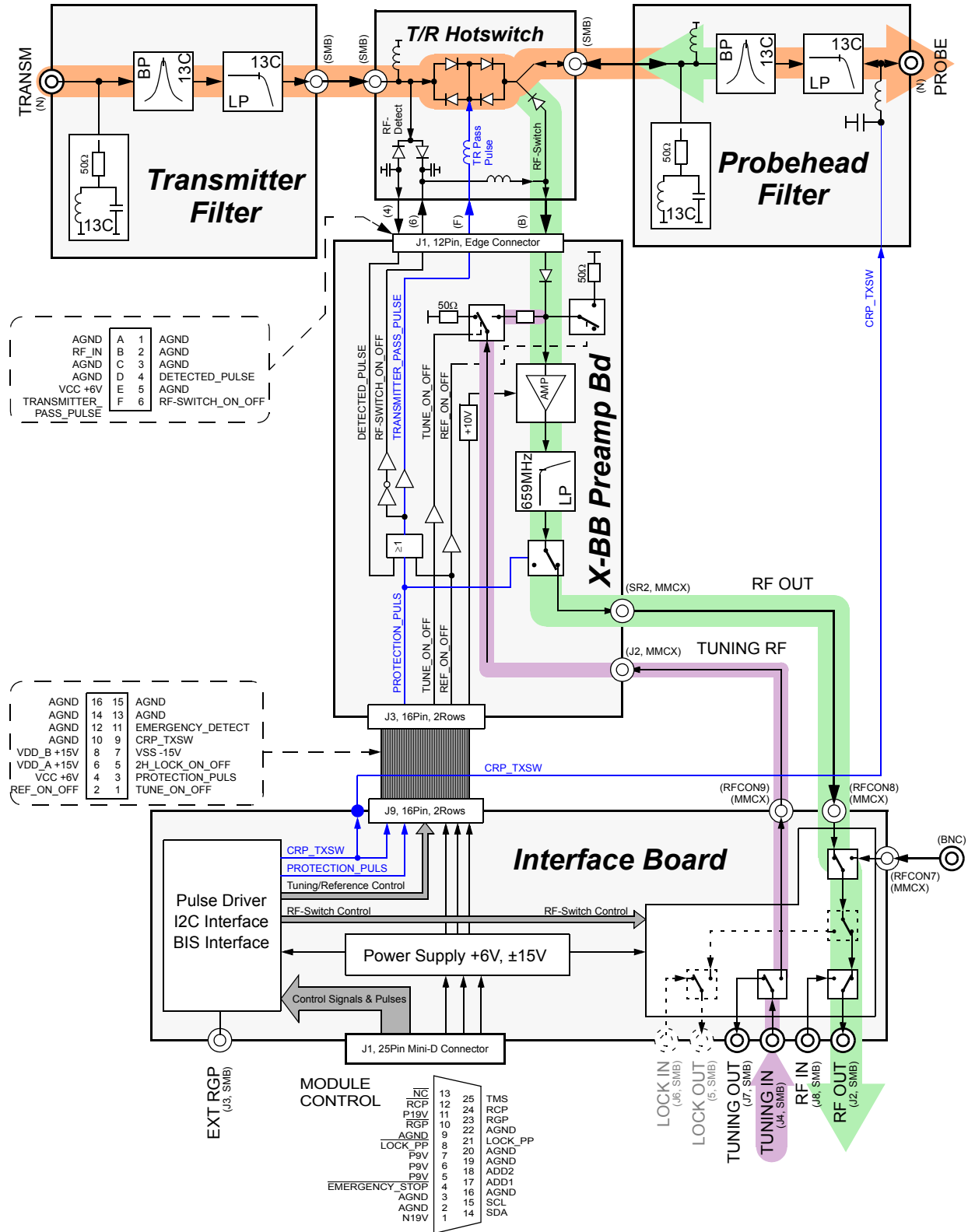
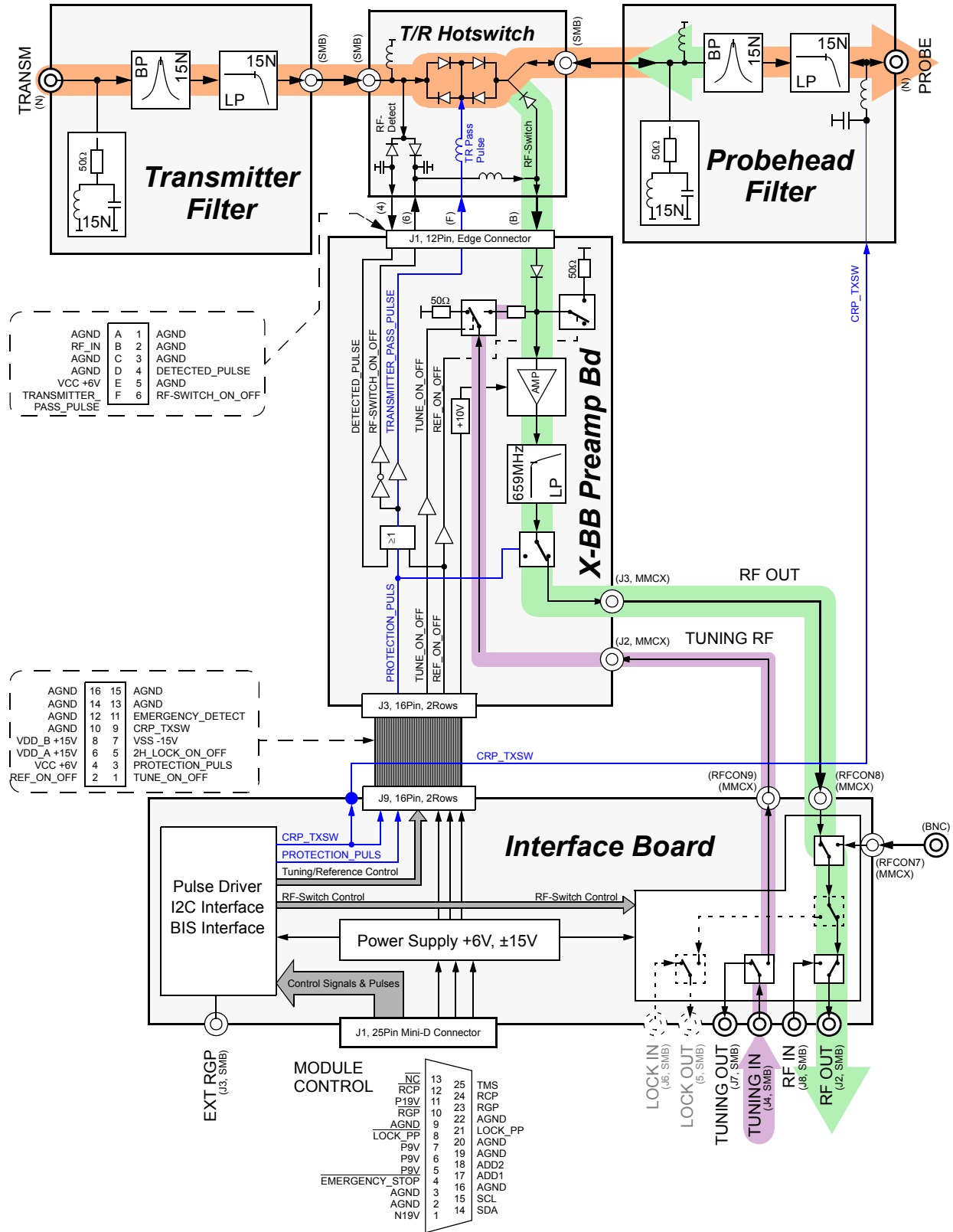

Figure 4.14. 15N Module Block Diagram



Figur 4.15. XBB-19F 2HS Module 300-400 Block Diagram

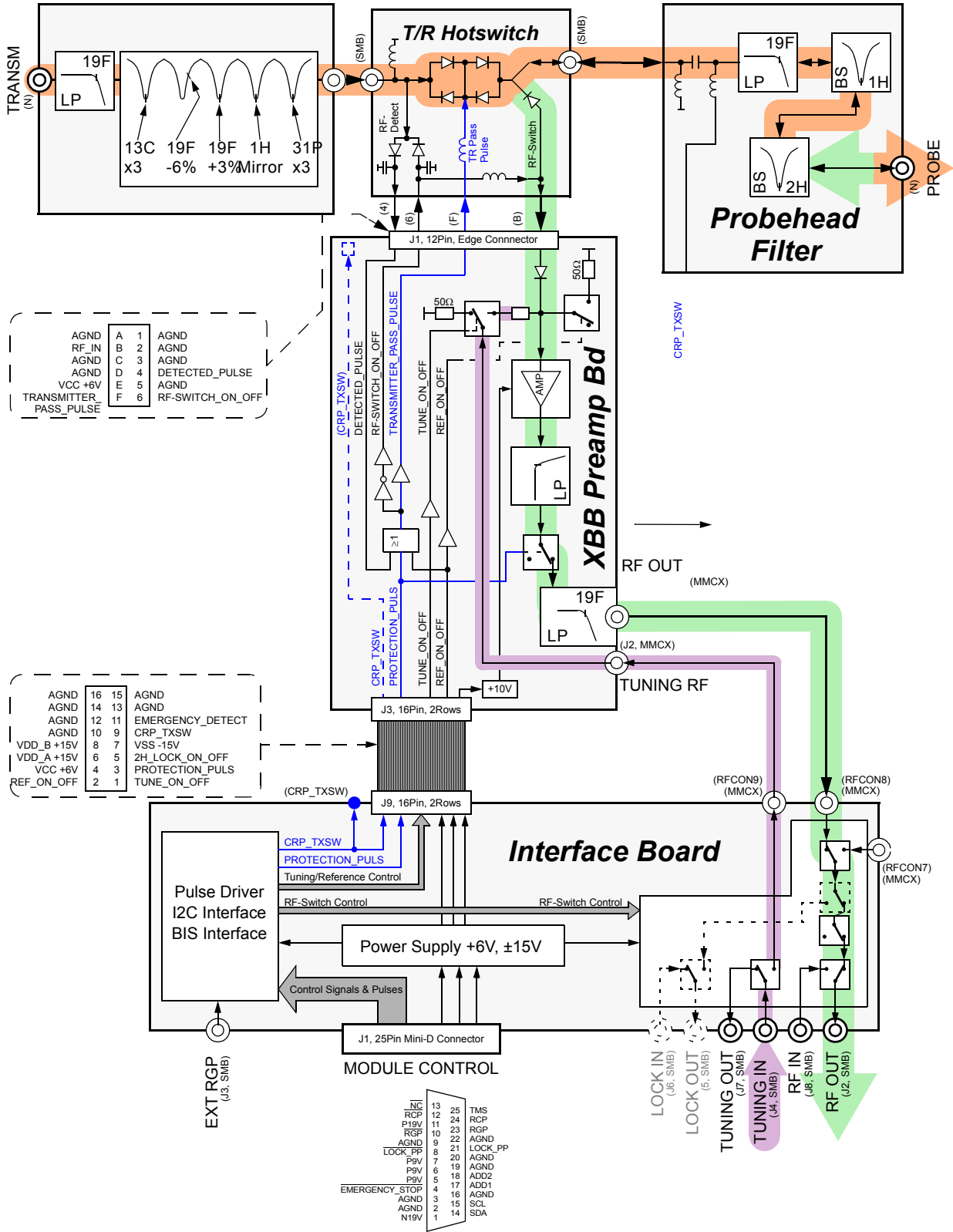

Figure 4.16. XBB-19F 2HS Module 500-700 Block Diagram

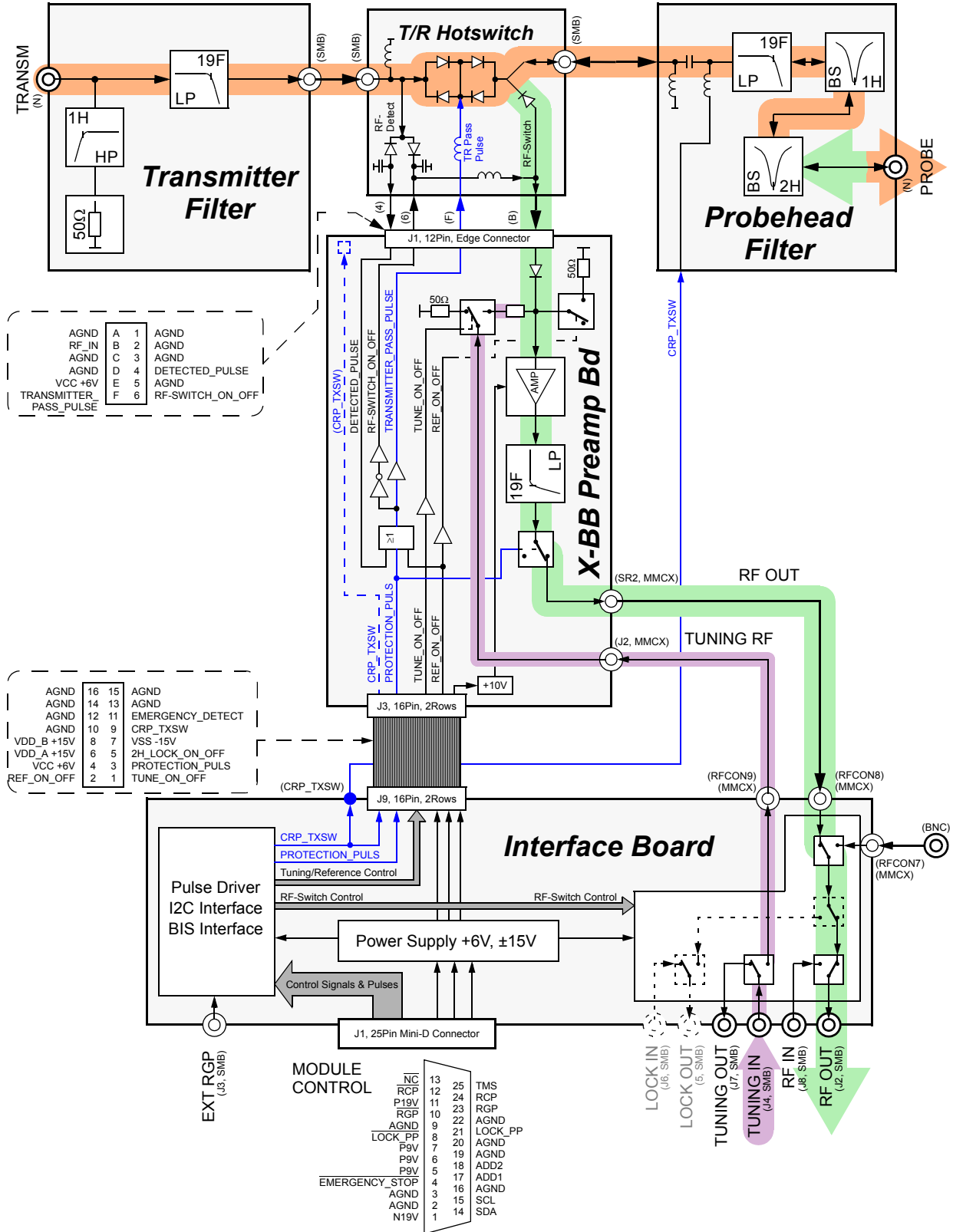

Figure 4.17. XBB-31P 2HS Module 750-950 Block Diagram

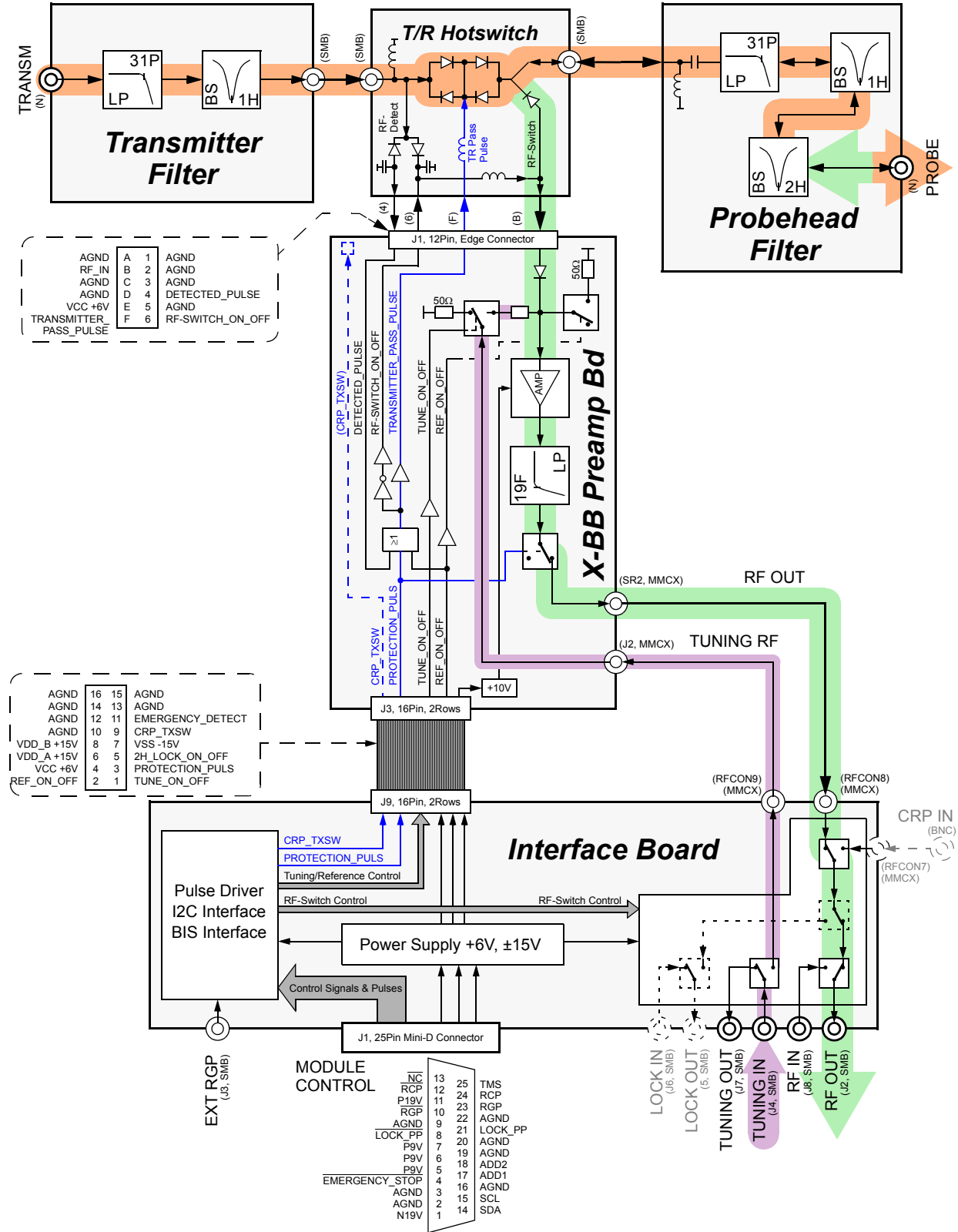

Figure 4.18. HPPR/2 19F/1H Module Block Diagram

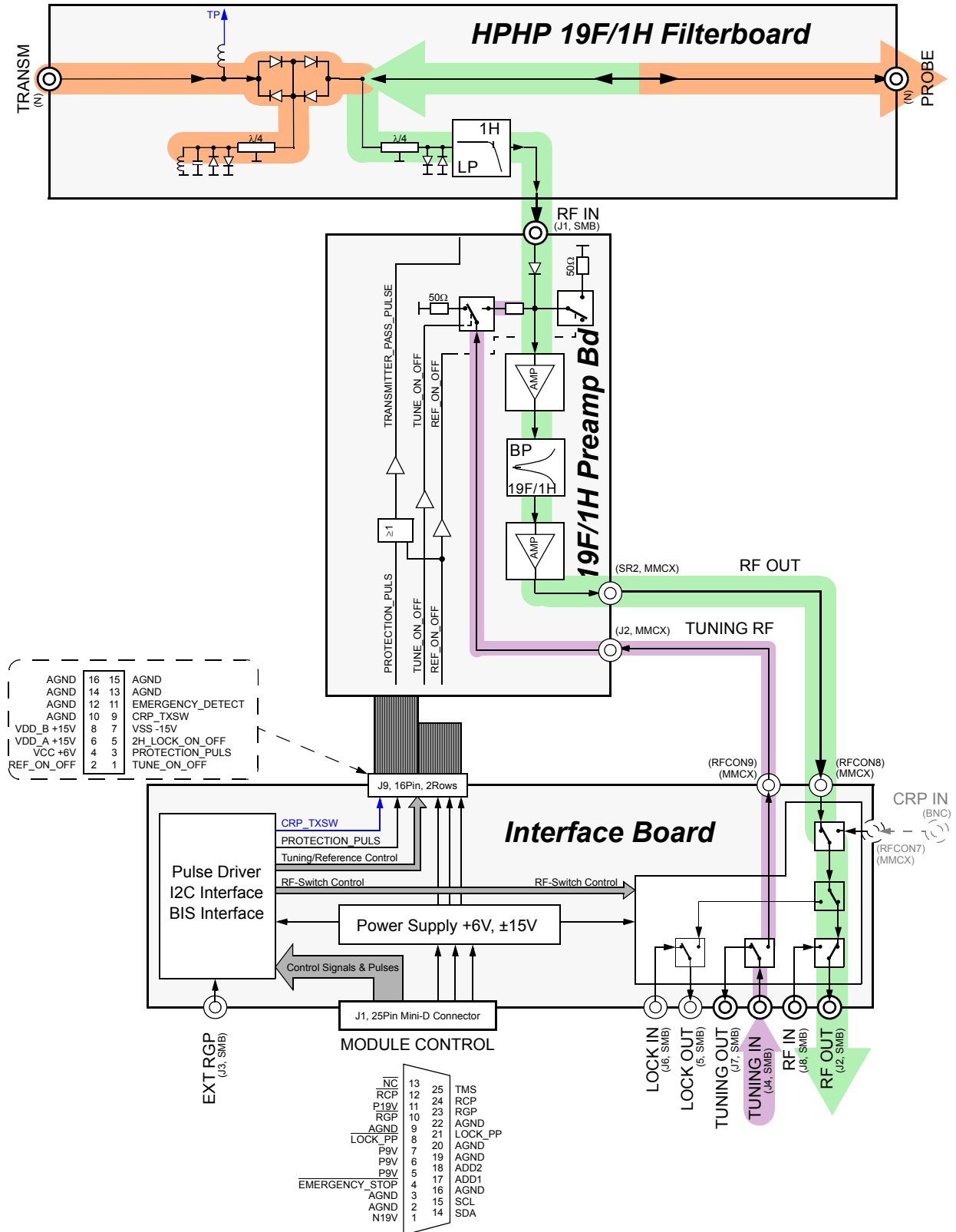
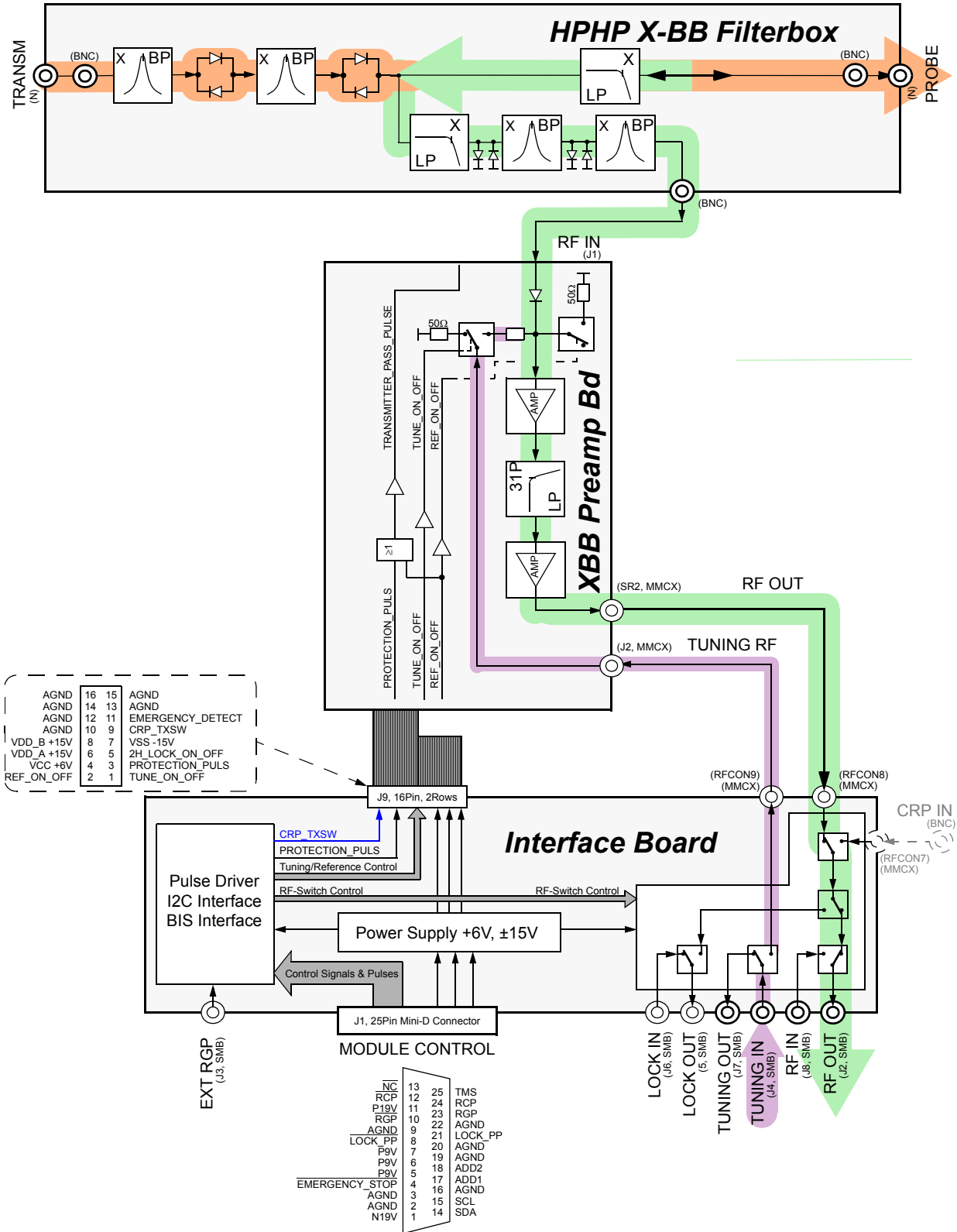

Figure 4.19. HPHP/2 XBB31P Module Block Diagram



Technical Specifications

4.4

Table 4.1. Technical Data HPPR/2 1H LNA MODULE

	500	600	700	750	800	900
Receive Path Performance						
Gain (typ)	28dB					
Noise Figure (typ)	1dB ^a			1.15dB ^a		
Transmit Path Performance						
Max. Power Rating	100W, 20us, 2% Duty Cycle					
Insertion Loss 1H	<=1.9dB ^a					

a without additional external filters

Table 4.2. Technical Data HPPR/2 1H HPLNA MODULE (MRI and Solids)

Solids		300	400	500	600	700	750	800	850	900	950
MRI	200	300	400	500	600	700	750				
Receive Path Performance											
Gain (typ)	28dB										
Noise Figure (typ)	1dB ^a										
1dB Compression Point	>-12dBm (Input Power)										
Transmit Path Performance											
Max. Power Rating	4kW, 10ms, 4% Duty Cycle 400W CW										
Insertion Loss 1H	<=0.6dB ^a										

a without additional external filters

Preamplifier Modules

Table 4.3. Technical Data HPPR/2 and AQS 1H2H MODULE

	300	400
1H Receive Path Performance		
Gain (typ)	30dB	
Noise Figure (typ)	1.4dB ^a	
1H Transmit Path Performance		
Max. Power Rating	150W ^b , 20us, 2% Duty Cycle	
Insertion Loss 1H (typ)	2.5dB ^a	
2H Receive Path Performance		
Gain (typ)	48dB	
Noise Figure (typ)	1.5dB	
2H Transmit Path Performance		
Max. Power Rating	300W, 20us, 2% Duty Cycle	
Insertion Loss 2H (typ)	2.2dB	

a all filters included

b valid for Z003958, Z003959 ECL \geq 04 and Z003950, Z003951 ECL \geq 03, former preamps have a maximal power rating of 100W

Table 4.4. Technical Data HPPR/2 2H MODULE

	500	600	700	750	800	850	900	950
Receive Path Performance								
Gain (typ)	45dB							
Noise Figure (typ)	2.8dB							
Transmit Path Performance								
Max. Power Rating	500W, 100us, 2% Duty Cycle							
Insertion Loss 2H	\leq 2dB							

Table 4.5. Technical Data HPPR/2 13C MODULE

	400	500	600	700	750	800	850	900	950
Receive Path Performance									
Gain (typ)	28dB								
Noise Figure (typ)	2.8dB								
Transmit Path Performance									
Max. Power Rating	500W, 100us, 2% Duty Cycle								
Insertion Loss 13C	<=2dB								

Table 4.6. Technical Data HPPR/2 15N MODULE

	400	500	600	700	750	800	850	900	950
Receive Path Performance									
Gain (typ)	28dB								
Noise Figure (typ)	2.8dB								
Transmit Path Performance									
Max. Power Rating	500W, 100us, 2% Duty Cycle								
Insertion Loss 15N	<=2dB								

Table 4.7. Technical Data HPPR/2 and AQS^a XBB19F 2HS MODULE

	300	400	500	600	700
Receive Path Performance					
Gain (typ)	28dB				
Noise Figure 13C (typ)	2dB ^b				
Transmit Path Performance					
Max. Power Rating	500W, 100us, 2% Duty Cycle				
Insertion Loss 13C	<=1dB				<=1.1

a for 300 and 400MHz only

b all filters are included for 300 and 400MHz preamplifiers (AQS and HPPR/2)

Preamplifier Modules

Table 4.8. Technical Data HPPR/2 XBB31P 2HS MODULE

	750	800	850	900	950
Receive Path Performance					
Gain (typ)	28dB				
Noise Figure 13C (typ)	2dB				
Transmit Path Performance					
Max. Power Rating	500W, 100us, 2% Duty Cycle		1000W, 100us, 2% Duty Cycle		
Insertion Loss 13C	<=1.2dB				

Table 4.9. Technical Data HPHP/2 19F/1H MODULE (obsolete, replaced by HPLNA 1H modules!)

	200	300	360	400	500	600	700	750	800	900
Receive Path Performance										
Gain 1H (typ)	28dB									
Noise Figure 1H (typ)	2.2dB					2.4dB			2.7dB	
Transmit Path Performance										
Max. Power Rating	1000W, 50ms, 10% Duty Cycle									
Insertion Loss 1H	<=2dB						<=2.3dB			

Table 4.10. Technical Data HPHP/2 XBB31P MODULE

	100-360	400-750	800-1000
Receive Path Performance			
Gain 1H (typ)	32dB		
Noise Figure ^a (typ)	1.6dB		
Transmit Path Performance			
Max. Power Rating	1000W, 50ms, 10% Duty Cycle		

a e.g. with Filterbox Z002696 120-210MHz

QNP Module

5

General

5.1

Figure 5.1. View

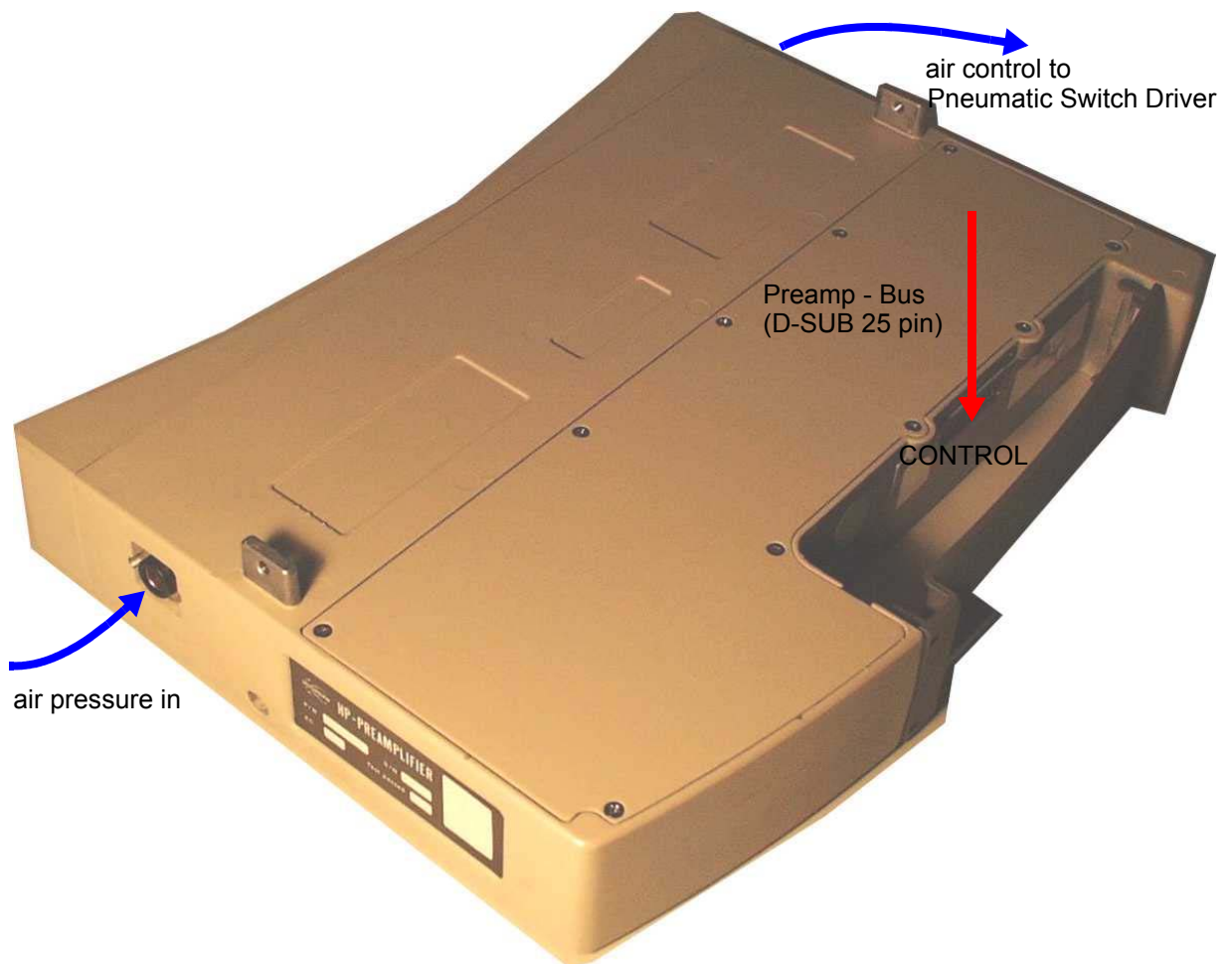

Using only one probe, the QNP System (Quadro Nucleus Probe) allows the measurement of four different nuclei, ^1H and three user determined nuclei, e.g. ^{19}F / ^{31}P / ^{13}C or ^{31}P / ^{13}C / ^{15}N . This is enabled by the triple-switchable measurement-channel in the QNP probe.

The QNP Module is the interface between the electronics and pneumatics. It is controlled electrically via the SBS bus (Console to Cover Module) and the Preamp - Bus (Cover Module to QNP Module). The LCD on the Cover Module shows the actual status. The three-level operation of the tuning-rod is controlled by two pneumatic cylinders in the Pneumatic Switch Drive. The associated control valve is positioned in the QNP Module.

Figure 5.2. Interfaces of QNP Module

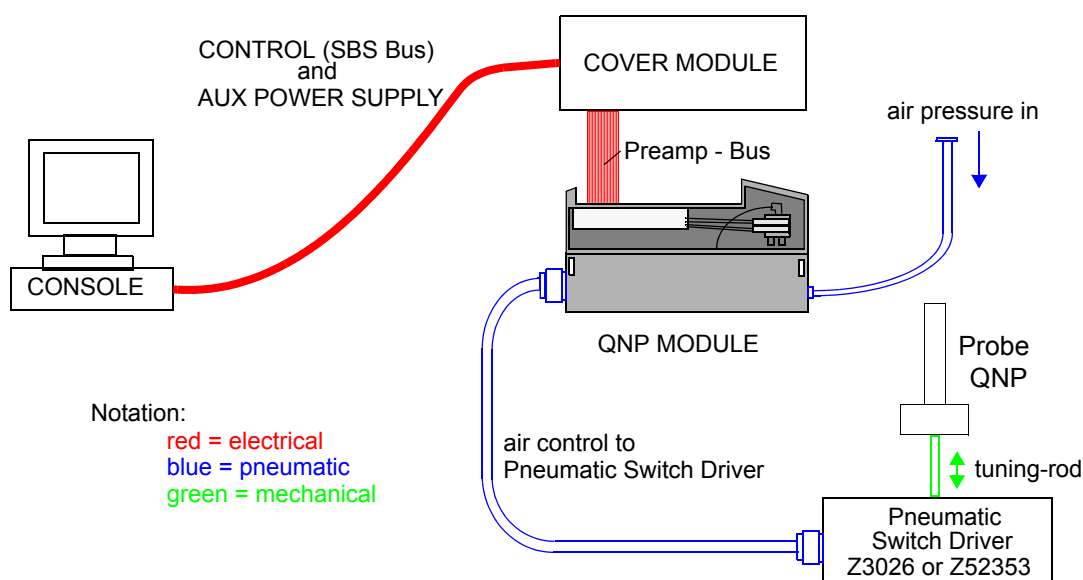

There is nothing special to know about the installation of the QNP Module. Just connect the QNP Module as bottom module and init the system with TopSpin ("cf"). Now the TopSpin should have found the QNP Module and you will be able to control the QNP probe by switching the air current with the connected QNP Module.

Figure 5.3. Block Diagram HPPR/2 QNP Module

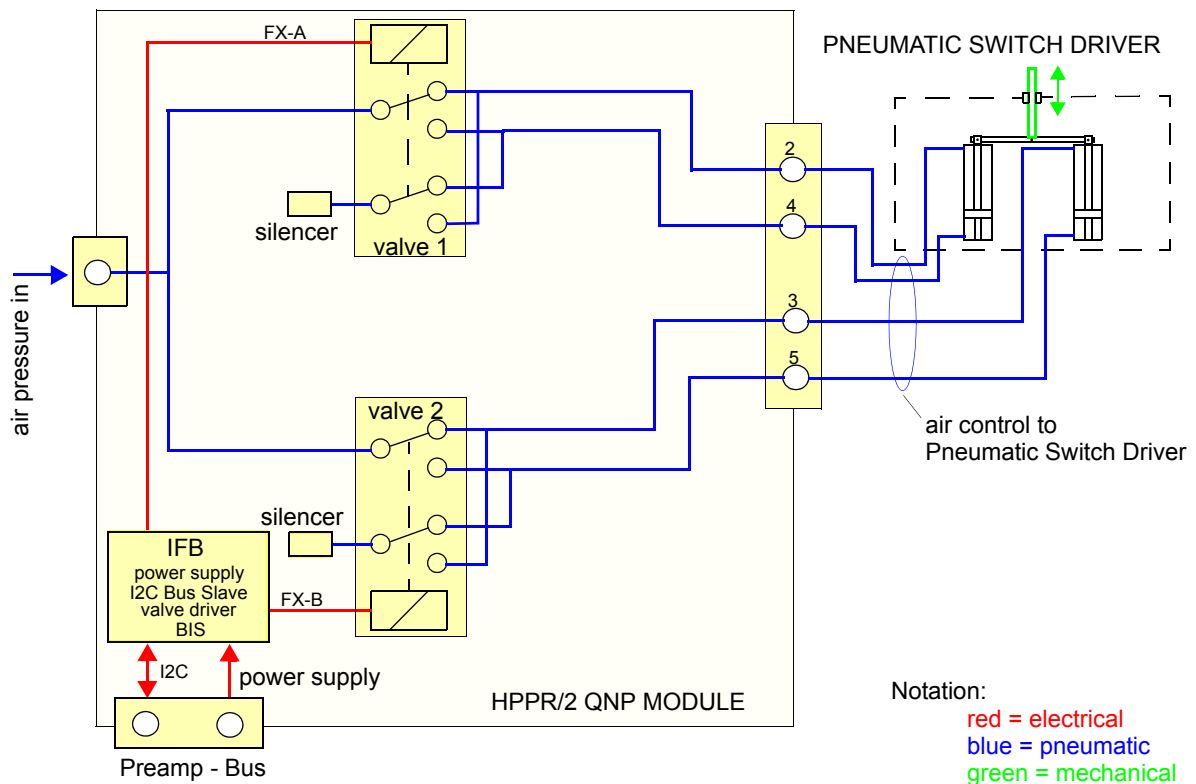

IFB (Interface Board)

The Interface Board (IFB) is the central control board in the QNP Module. It contains following parts:

1. power supply and monitoring for internal and valve control voltage
2. I2C Bus slave interface
3. valve control driver
4. BIS (Bruker Information System)

This function blocks will be described in the following chapters.

Power Supply and Monitoring

The QNP Module uses the HPPR +9V voltage for supplying the control logic on the IFB and the HPPR +19V for controlling the pneumatic valve.

Both voltages are supplied via Preamp-Bus from Cover Module and are filtered and stabilized on the IFB. The operation of the on-board power stabilization is monitored. In case of failure, the HPPR/2 Cover Module will create an error and will display the corresponding error message on its LCD.

I2C Bus and Addressing

The QNP Control Module is an I2C slave device. The Cover Module is the master device which controls all slave devices on the Preamp-Bus. The addressing of the device is done by a daisy chain automatically. Therefore there mustn't be left any gaps in the Preamp-Bus connector and unused connections from the Preamp-Bus cable have to be after the last connected module.

Valve Control Driver

The pneumatic valve are driven by a 12 volt totem pole high current driver which is placed on the IFB.

BIS

The HPPR/2 QNP Module BIS data contains information about production data, ECL, hardware type, name and type of the module.

BIS information is provided via I2C bus to the Cover Module and can be read using UniTool commands.

Valve

5.2.3

There are used customer specified pneumatic valves for switching the air to the Pneumatic Switch Driver (for block diagram see [Figure 5.3](#)). The valves are controlled by a 12 volt signal.

With these two valves it is possible to drive three different QNP probe positions. There are following rules:

Table 5.1. True Table Pneumatic Valve

Pos.	Valve 2	Valve 1	Switch Drive Position	Frequency
1 ^a	off	off	bottom	maximum
2 ^b	off	on	middle	medium
2	on	off	middle	medium
3	on	on	top	minimum

a default after power-up

b not used since identical with next status

Connectors

5.2.4

Air pressure in

The air pressure is supplied at the "TRANSM" connector. There is a maximum pressure of 600 kPa (= 6 bar = 87 psi) allowed.

Air control to Pneumatic Switch Drive

There are four air hoses leading to the Pneumatic Switch Drive to control the QNP probe position.

The **Table 5.1.** shows how the position of the Pneumatic Switch Drive is controlled through the pneumatic valves and the corresponding air hoses.

Preamp-Bus

The QNP Module is fully electrically controlled via the Preamp-Bus. This is the same bus which is also connected to the HPPR/2 preamplifier modules.

The Preamp-Bus contains a I2C bus for controlling the module and a +9V / +19V for supplying the module. The Power Supply -19V, the Emergency Stop and real time pulse signals are not used for the QNP Module.

Table 5.2. Preamp-Bus connector: DSUB 25 pin

Signal Name	Pin No.	Remark
HPPR +19V	11	HPPR/2 power supply
HPPR -19V	1	
HPPR +9V	5, 6, 7	
GND	2, 3, 9, 16, 19, 20, 22	
EMERGENCY_STOP	4	Emergency Stop signal
RGP_HPPR	23	Real time pulse signals
$\overline{\text{RG P_HPPR}}$	10	
LOCK_PP	8	
$\overline{\text{LOCK_PP}}$	21	
INTERLEAVE_INCR	24	
$\overline{\text{INTERLEAVE_INCR}}$	12	
SCL	15	I2C bus clock and data signal
SDA	14	
ADDR1	17	Daisy chain for addressing the modules.
ADDR2	18	

HPPR/2 Module Configurations

6

Introduction

6.1

The following chapter gives an introduction to commonly used HPPR/2 module configurations.

Other configurations are principally possible. To the following rules should be paid attention: The QNP module is always the one at the bottom followed by the high power modules (HPHP/2). The high resolution modules are always on the very top.

For standard wiring (no multiple RX) see "Installation" on page 11.

HPPR/2 Configurations for High Resolution

6.2

Figure 6.1. HPPR/2 Configuration for High Resolution

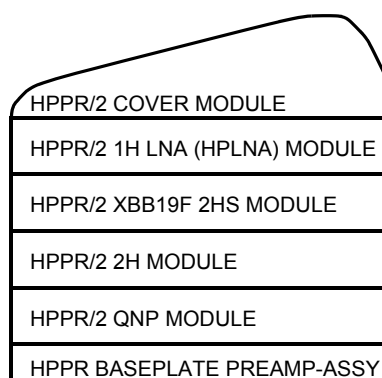

HPPR/2 Module Configurations

Figure 6.2. HPPR/2 Configuration with 1H2H Module

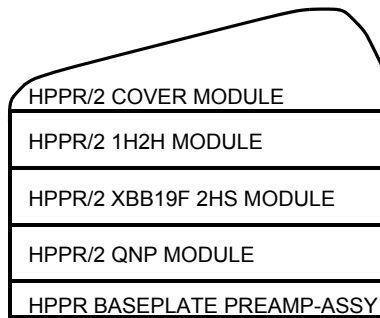

Figure 6.3. HPPR/2 Configuration with two XBB Module

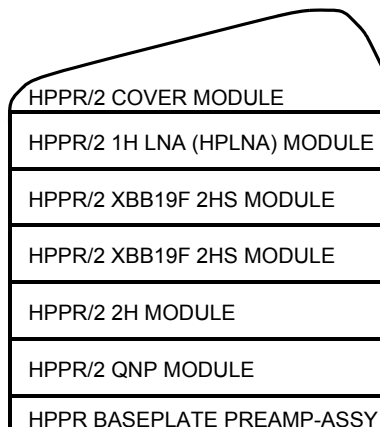

Figure 6.4. HPPR/2 Configuration with 1H2H Module and two XBB Module

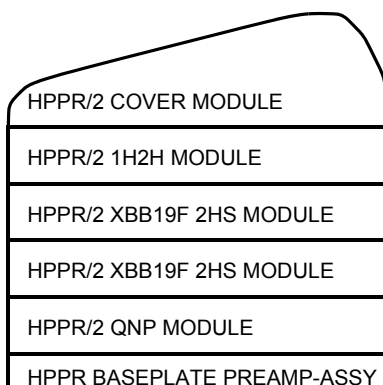
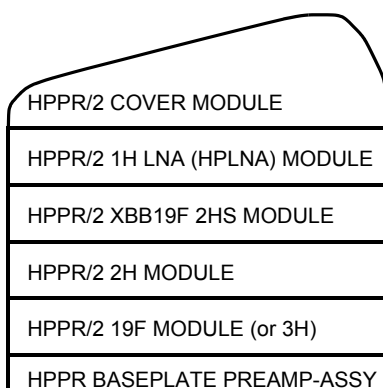
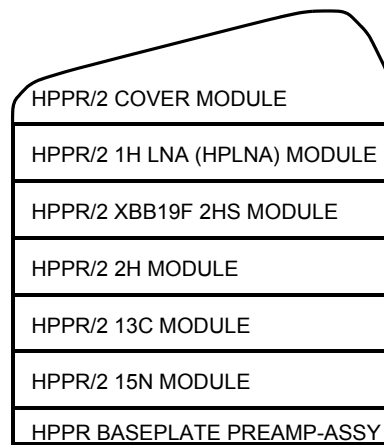

Figure 6.5. HPPR/2 Configuration with selective 19F Module or 3H Module



HPPR/2 Module Configurations

Figure 6.6. HPPR/2 Configuration for Cryoprobe



HPPR/2 Configurations for High Power

6.3

Figure 6.7. HPPR/2 Configuration with HPHP/2 or HPLNA 1H Modules

Classical configuration

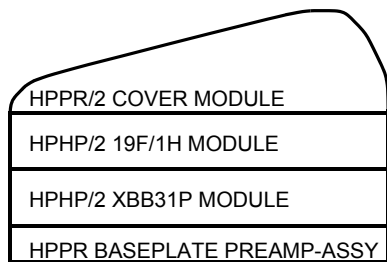

New configuration with 1H HPLNA

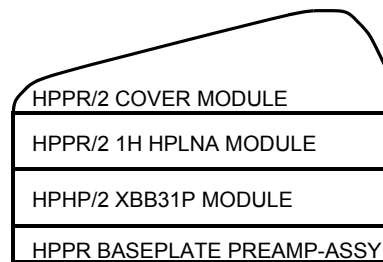

Figure 6.8. HPPR/2 Configuration for High Resolution and High Power

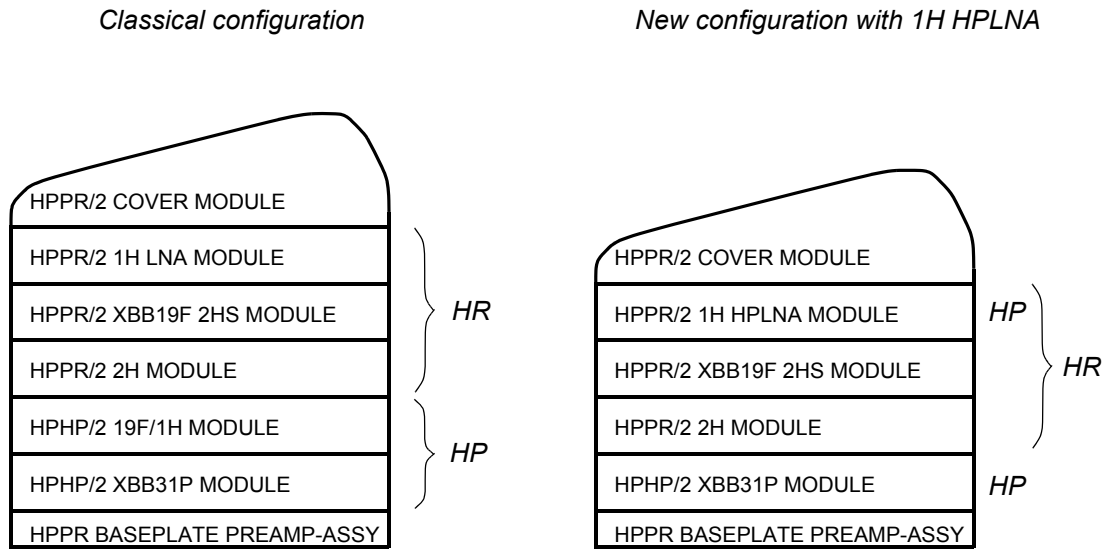
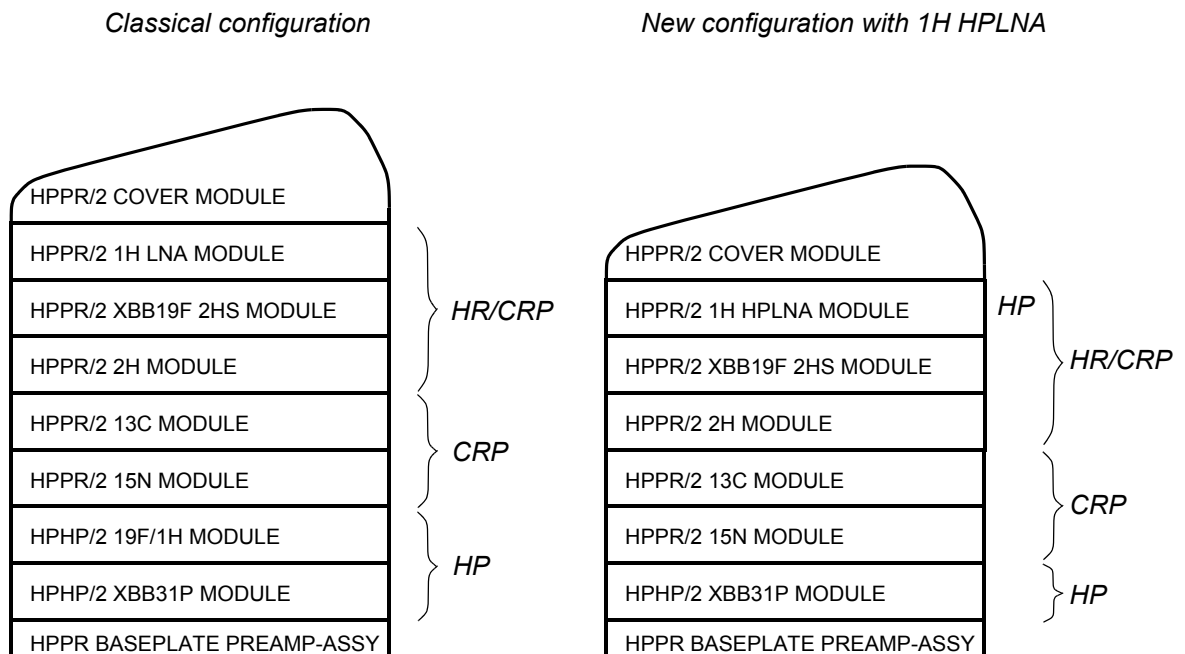

Figure 6.9. HPPR/2 Configuration for High Resolution, High Power and CRP



MRI-Interface Module

7

Figure 7.1. View HPPR/2 MRI-INTERFACE Modules



The MRI Interface modules provide the connection between the coil array (incl. array preamps), the preamplifier modules and the receiver boards in the AQS chassis. There are three modules:

- HPPR/2 MRI-INTERFACE MODULE RF1-4 (Z106268)
- HPPR/2 MRI-INTERFACE MODULE RF5-10 (Z106269)
- HPPR/2 MRI-INTERFACE MODULE RF11-16 (Z106270)

! *These modules contain neither active components nor BIS information.*

The module RF1-4 contains 4 rf-channels. Channel 1 and 2 are routed via connectors to the HPPR/2 preamplifier modules. The interconnections for two tuning signals and two external blanking pulses are also provided.

Figure 7.2. Block diagram IF-Module RF1-4

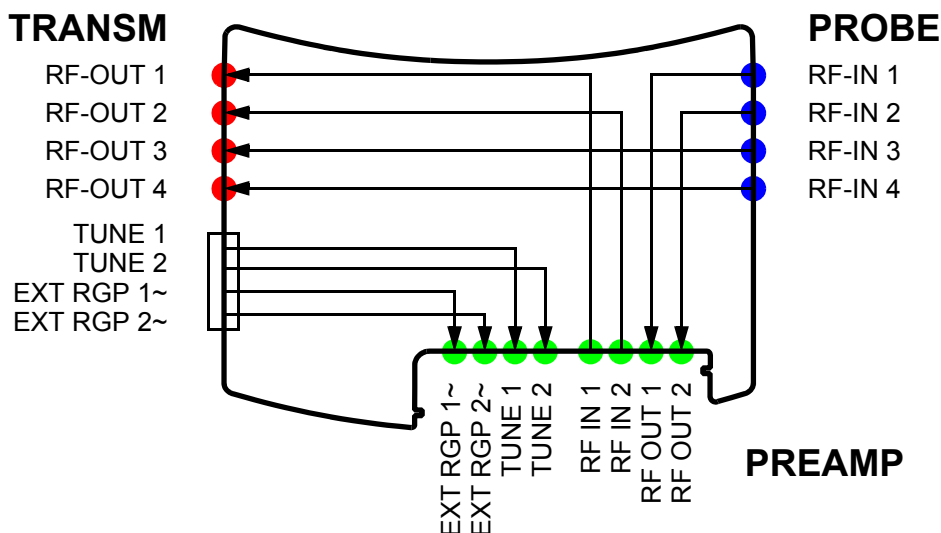

The modules RF5-10 and RF11-16 contain six straight through rf-channels each. Both modules are, apart from for the connector labels, identical.

Figure 7.3. Block diagram IF-Module RF5-10 & RF11-16

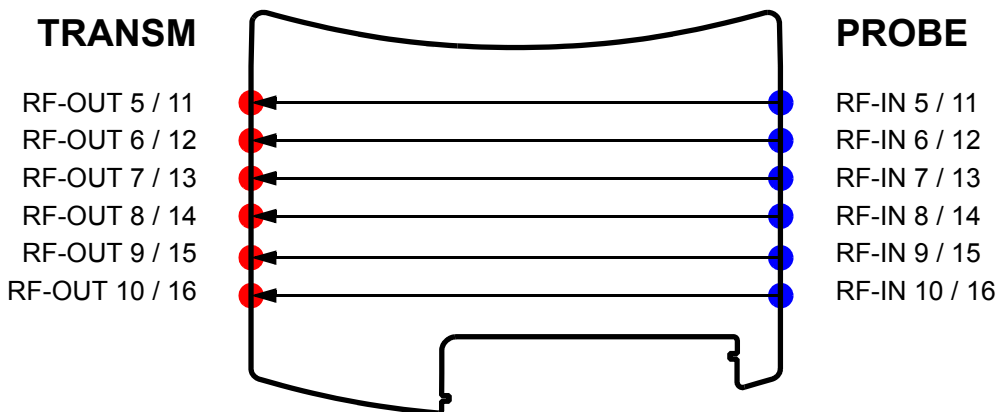

Figure 7.4. View PROBE Connectors

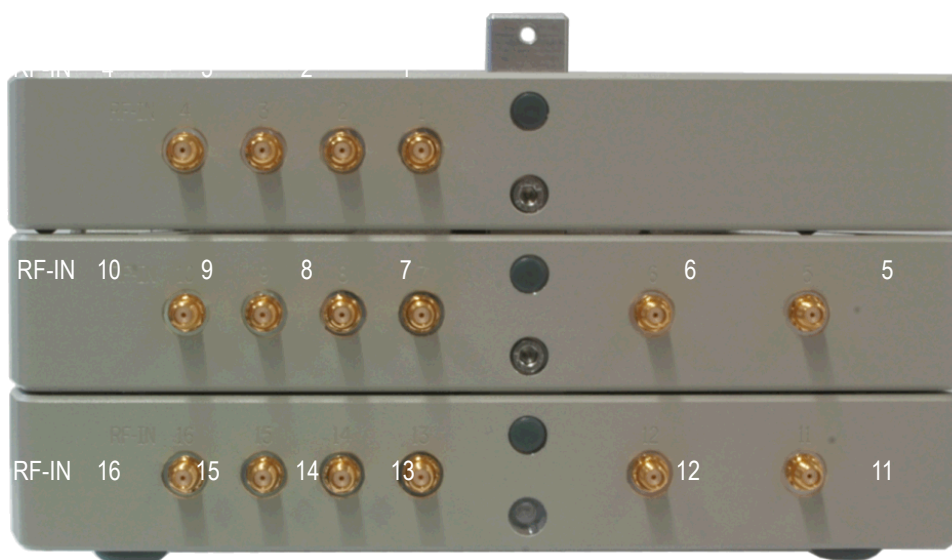

Figure 7.5. View TRANSM Connectors



MRI-INTERFACE MODULE

Figure 7.6. View PREAMP Connectors

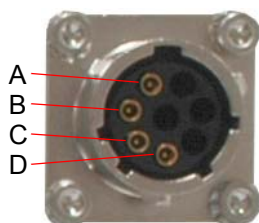

Table 7.1. Connector Description

Position	Label	Connector Type	Description
PROBE	RF IN	SMA (coax female)	RF input signal from coil or array preamp
TRANSM	RF OUT TUNE / EP	N (coax female) UT0 8pol. (multicoax female)	RF output signal to RXAD Receiver gating pulse from RXAD and tuning signal from SGU
PREAMP ^a	RF IN RF OUT EXT_RGP~ TUNE	SMB (coax male)	RF input from preamplifier module RF output to preamplifier module Receiver gating pulse output to preamplifier module Tuning signal output to preamplifier module

a IF-Module RF1-4 only

Table 7.2. Pinout TUNE / EP connector



Pin	Type	Signal
A	RCDX	TUNE 1
B	RCDX	TUNE 2
C	RCDX	EXT_RGP1~
D	RCDX	EXT_RGP2~

The following wiring lists describe the wiring between the MRI INTERFACE MODULE RF1-4 and the PREAMP modules. The necessary cables and terminators are either delivered with the interface module or the PREAMP modules.

Figure 7.7. MRI Interface Module Configurations

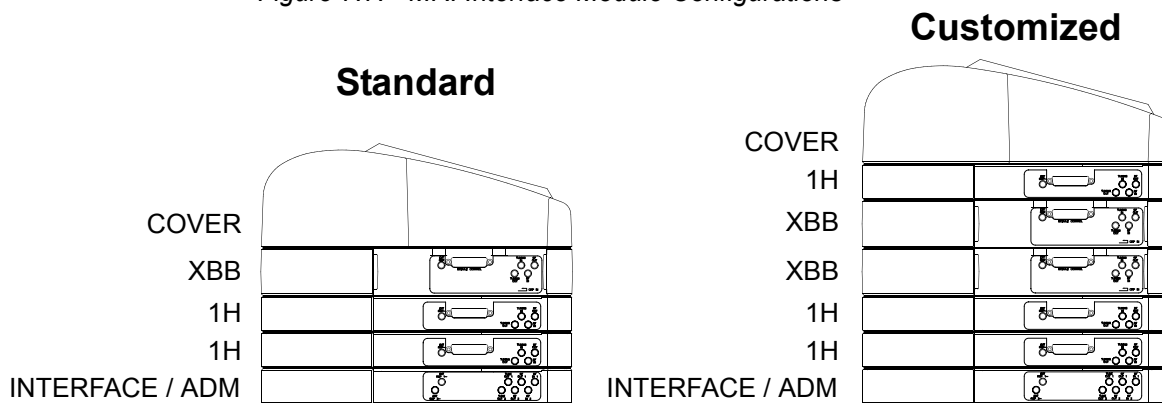

Table 7.3. MRI Interface Module Wiring: Standard BioSpec

Pos.	Cable		Module (top to bottom)			
	Mat. Nr.	Length (mm)	HPPH/2 XBB31P	HPPR/2 1H HPLNA	HPPR/2 1H HPLNA	HPPR/2 MRI INTERFACE
1	Z106224	140	RF IN	-----		RF OUT 1
2	Z106224	140	RF OUT	-----		RF IN 1
3	Z106224	140	TUNING IN	-----		TUNE OUT 1
4	Z106224	140	EXT RGP~	-----		EXT RGP 1~
5	42869	50Ω Terminator	TUNING OUT			
6	Z106223	90		RF OUT	-----	RF IN 2
7	Z106223	90		TUNING IN	-----	TUNE OUT 2
8	Z106223	90		EXT RGP~	-----	EXT RGP 2~
9	Z13855	50		RF IN	RF OUT	
10	Z13855	50		TUNING OUT	TUNING IN	
11	Z13855	50			RF IN	RF OUT 2

MRI-INTERFACE MODULE

Table 7.4. MRI Interface Module Wiring: Customized BioSpec

Pos.	Cable		Module (top to bottom)					
	Mat. Nr.	Length (mm)	HPPR/2 1H HPLNA	HPHP/2 XBB31P	HPHP/2 XBB31P	HPPR/2 1H HPLNA	HPPR/2 1H HPLNA	HPPR/2 MRI INTERFACE
1	Z13855	50	RF IN	RF OUT				
2	Z13855	50	TUNING OUT	TUNING IN				
3	Z106225	245	RF OUT	-----				RF IN 1
4	Z106225	245	TUNING IN	-----				TUNE OUT 1
5	Z13855	50		RF IN	RF OUT			
6	Z13855	50		TUNING OUT	TUNING IN			
7	Z106224	140			EXT RGP~	-----		EXT RGP 1~
8	Z106224	140			RF IN	-----		RF OUT 1
9	42869	50Ω			TUNING OUT			
10	Z106223	90				RF OUT	-----	RF IN 2
11	Z106223	90				TUNING IN	-----	TUNE OUT 2
12	Z106223	90				EXT RGP~	-----	EXT RGP 2~
13	Z13855	50				RF IN	RF OUT	
14	Z13855	50				TUNING OUT	TUNING IN	
15	Z13855	50					RF IN	RF OUT 2

Figure 7.8. Measurement Path

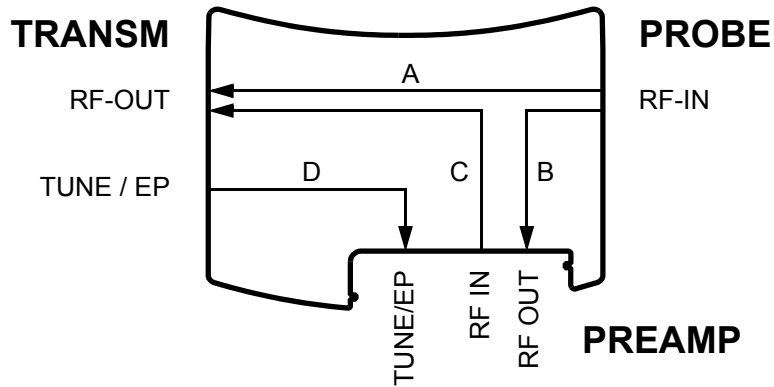

Insertion loss (S21): 0.005..0.5GHz / 0.5..1GHz

Path A:	max. 0.3 / 0.5	dB
Path B, C and D:	max. 0.6 / 1.0	dB

VSWR (S11): 0.005..1GHz

All connectors path A, B and C:	max. 1.2:1	-
All connectors path D:	max. 1.4:1	-

Installation

7.5

The interface modules are designed to be at the bottom of the preamplifier module stack. They can be placed directly on the floor. No additional baseplate is needed.

All interface modules are factory equipped with large rubber feet. These must be removed before the modules are stacked on top of each other. The large rubber feet remain only on the bottom module.

MRI Active De-Tuning Module

8

Figure 8.1. View HPPR/2 MRI ACTIVE DETUNING Module



The HPPR/2 MRI ACTIVE DETUNING Module (ADM, Z107408) belongs to the group of MRI interface modules. It combines the functionality of the former BIO ACT DEC/COIL CONTROL UNIT (T5051) and the HPPR/2 MRI-INTERFACE MODULE RF1-4 (Z106268).

Figure 8.2. Block diagram ADM Module

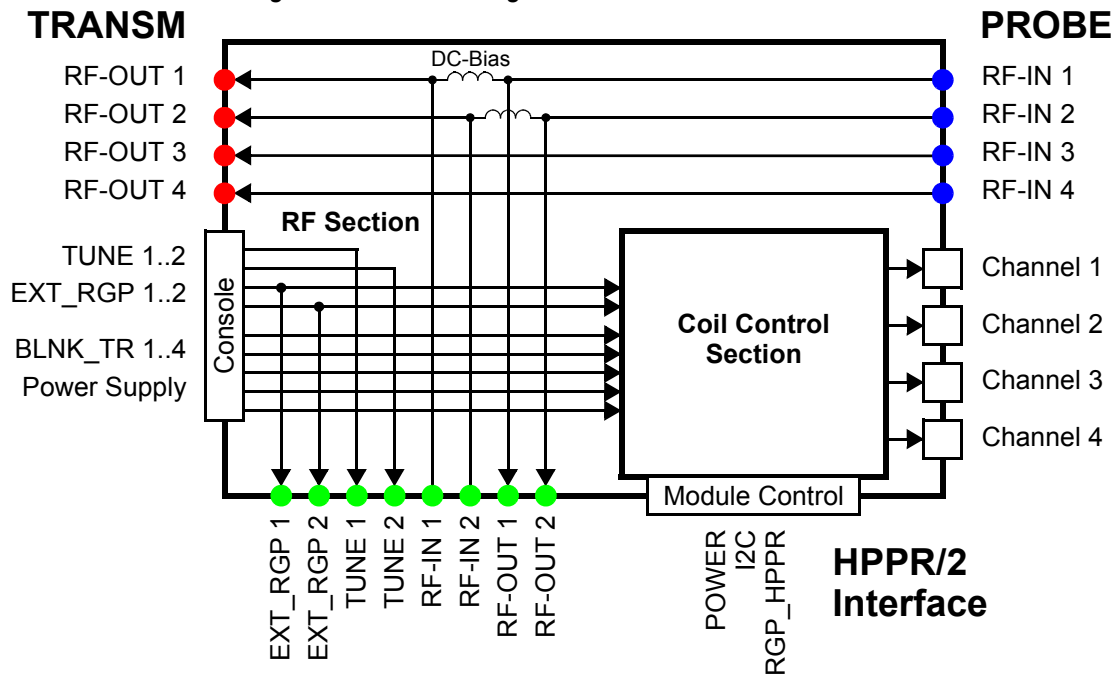

RF-Section

8.1.1

The ADM module rf section is basically the same as in the MRI-Interface module RF1-4. It provides the connections between the coil array (incl. array preamps), the preamplifier modules and the receiver boards in the AQS chassis. It contains 4 rf-channels. Channel RF1 and RF2 are routed via connectors to the HPPR/2 preamplifier modules. Two dc-bias between the preamplifier connectors enables the array preamp supply current to flow through the module. The interconnections for two tuning signals and two external RGP pulses are also provided.

The rf-section contains no active components, only interconnections, dc-bias and coaxial cables. There is no connection to the coil control section, except for the two EXT_RGP pulses which are used as inputs.

The ADM module coil control section provides detuning pulses and coil control signals for four independent coil channels (coil connectors). Each channel contains four PIN-diode drivers, four tuning/matching signals, two tune control signals 0° and 90° for quad coils, one RGP signal, a LOGIC_SEL input and auxiliary power supply pins (+5V, +9V, -30V).

Figure 8.3. Block diagram Coil Control Section

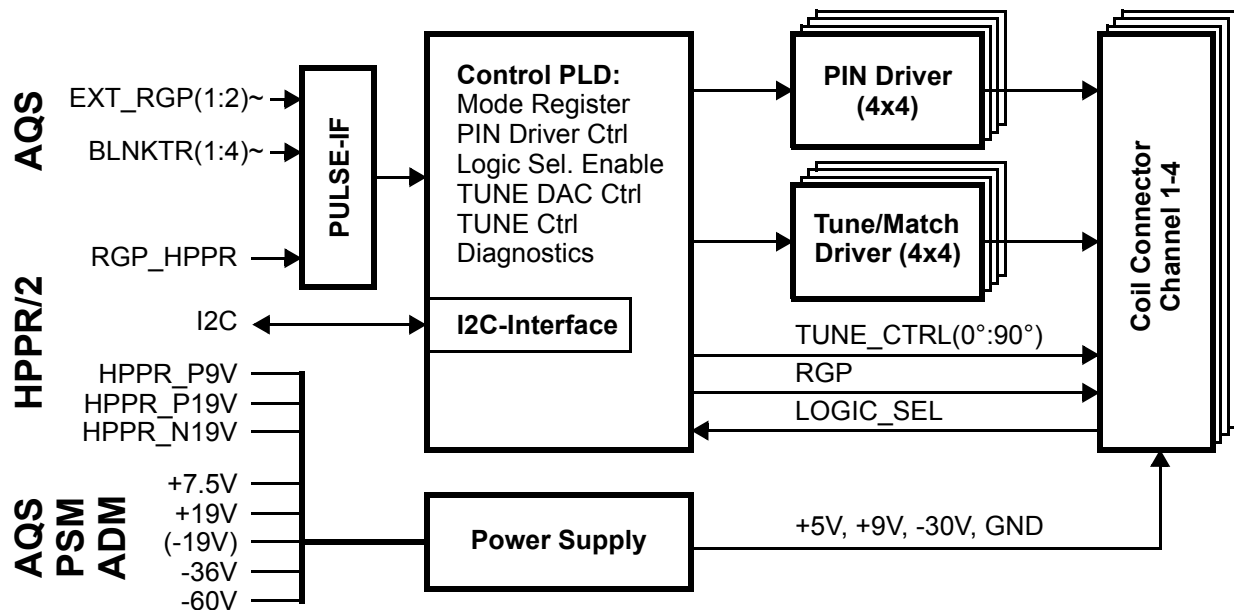

The ADM module uses seven input pulses:

- RGP_HPPR: common RGP for all preamplifier modules
- EXT_RGP(1:2)~: discrete RGP from AQS RXAD1 & 2
- BLNKTR(1:4)~: discrete transmitter blanking pulse from AQS PSD

The pulses are used for PIN driver, tune/match driver and RGP output pulse control. The RGP_HPPR pulse is connected via the module control connector (flat ribbon cable), the other pulses via the console connector (coaxial cables).

Each driver can be controlled independently either in static mode or by the input pulses. The seven input pulses can be OR combined via software setting. The pulse polarity is either set via the LOGIC_SEL input from the coil connector for all drivers of one channel together or via software for each driver individually.

The positive (forward) output voltage level is between +3 and +5V, depending on the load current. In voltage mode the maximum load current is 0.5A per driver. If

MRI ACTIVE DETUNING MODULE

the current exceeds this limit, all drivers of the channel are shut down and set into stand-by mode. In current mode the load current is limited to 0.1A per driver. The negative (reverse) output voltage level can be set either to -36V or -60V.

The LOGIC_SEL input enable, driver mode (voltage or current) and negative voltage level settings are always valid for all four drivers of a channel together.

Tune/Match Driver Function

8.1.5

Each coil channel has four tuning drivers for varicap diodes: Tune 0°, Match 0°, Tune 90° and Match 90°. All drivers are DAC controlled with a resolution of 12 bits. The output voltage level is between 0 and -30V.

Each DAC has two data registers A and B. This allows fast switching between two adjustable output voltages. To toggle between these, any OR-combination of the seven input pulses can be used. The toggle mode is set individually for each driver.

RGP Output Pulse

8.1.6

Each coil channel has one RGP output pulse. The pulse can be selected from the three input pulses RGP_HPPR, EXT_RGP(1)~ or EXT_RGP(2)~ individually for each channel.

Diagnostic Function

8.1.7

The ADM module has 48 internal diagnostic testpoints. Each one can be routed with analog switches to a 12bit ADC. The ADC output data is then converted to a voltage value by the HPPR/2 controller.

There are testpoint for all input pulses, all PIN- and tune/match driver outputs and a selection of power supply voltages.

Software Control

8.1.8

The ADM module is controlled entirely via I2C bus by the HPPR/2 controller in the cover module. The ADM has no internal microcontroller. The HPPR/2 controller receives the commands via SBSB from the host software (ParaVision or TopSpin).

For service purposes UniTool can be used with a basic set of commands, including access to the internal diagnostics.

Figure 8.4. View PROBE Connectors

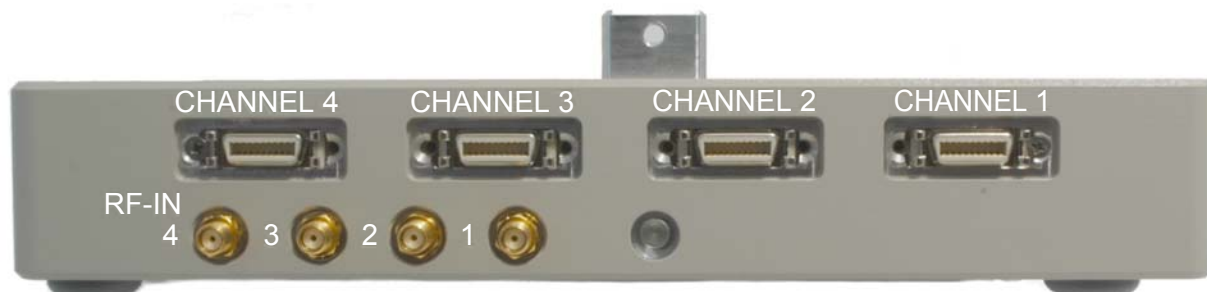

Figure 8.5. View TRANSM Connectors

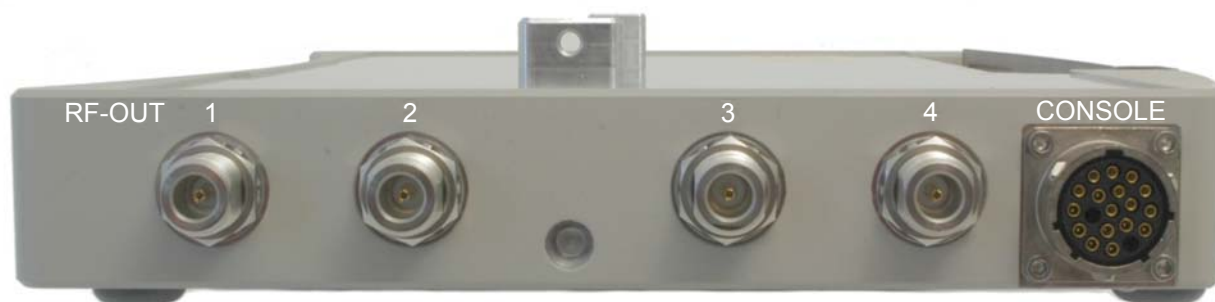
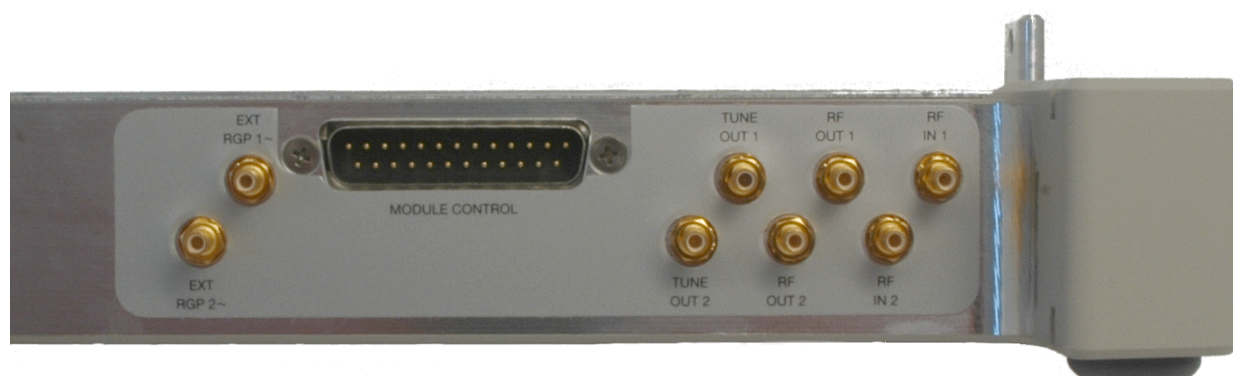

Figure 8.6. View PREAMP Connectors



MRI ACTIVE DETUNING MODULE

Table 8.1. Connector Description

Position	Label	Connector Type	Description
PROBE	CHANNEL	MDR (mini-delta ribbon female)	Detuning output signals to coil connector
	RF IN	SMA (coax female)	RF input signal from coil or array preamp
TRANSM	RF OUT	N (coax female)	RF output signal to AQS RXAD
	CONSOLE	UT0 19pol. (multiple coax and dc contacts)	Receiver gating pulses from AQS RXAD Blanking pulses and tuning signals from AQS PSD Power supply from AQS PSM ADM
PREAMP	RF IN RF OUT EXT_RGP~ TUNE	SMB (coax male)	RF input from preamplifier module RF output to preamplifier module Receiver gating pulse output to preamplifier module Tuning signal output to preamplifier module

Table 8.2. Pinout CHANNEL Connector

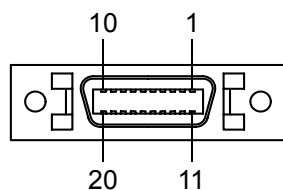

Pin	Signal	Pin	Signal
1	PIN DRV 1	11	PIN DRV 2
2	PIN DRV 3	12	PIN DRV 4
3	TUNE 0°	13	MATCH 0°
4	COIL +9V / 0.2A	14	COIL -30V / 20mA
5	TUNE 90°	15	MATCH 90°
6	GND	16	GND
7	+5V	17	LOGIC_SEL
8	<i>not connected</i>	18	<i>not connected</i>
9	GND	19	RGP
10	TUNE CONTROL 0°	20	TUNE CONTROL 90°

Table 8.3. Pinout CONSOLE Connector

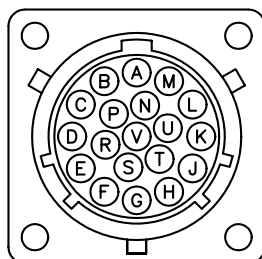

Pin	Type	Signal	Pin	Type	Signal
A	dc	P19V	L	dc	GND
B	dc	GND	M	dc	P7V
C	dc	P7V	N	dc	N36V
D	coax	BLNKTR(2)~	P	coax	EXT_RGP(2)~
E	coax	BLNKTR(1)~	R	dc	<i>IPSOT2X_SCO/CCO</i>
F	coax	BLNKTR(4)~	S	coax	TUNE(1)
G	coax	BLNKTR(3)~	T	coax	TUNE(2)
H	dc	<i>N19V</i>	U	dc	N60V
J	coax	EXT_RGP(1)~	V	dc	NSENSE_P7V
K	dc	PSENSE_P7V	<i>italic = not used in ADM</i>		

Power Supply

8.3

The ADM module uses two power supply sources. Three voltages (HPPR_P9V, HPPR_P19V, HPPR_N19V) are supplied from the cover module via the module control connector (flat ribbon cable). Four additional voltages (+7.5V, +19V, -36V, -60V) are supplied from the new AQS PSM ADM (Z107413). This power supply is situated at the back of the AQS chassis. It is connected to the ADM module via the console connector.

For additional information on the AQS PSM ADM please refer to the AQS technical manual.

RF-Wiring

8.4

The rf-wiring is the same as with the HPPR/2 MRI INTERFACE MODULE RF1-4. Please refer to that section of this manual.

Inputs:

RGP_HPPR, RGP_HPPR~: (from cover mod.)	RS-422 differential	--
EXT_RGP(1:2)~: (from RXAD)	+5V TTL	--
BLNKTR(1:4)~: (from PSD)	+5V TTL	--
LOGIC_SEL: (from coil connector)	open/1k Ω pull-down or +5V TTL	--

PIN-Diode Driver:

Positive (forward) output voltage: (voltage mode)	+3..6	Vdc
Positive (forward) output current: (voltage mode)	max. 0.5	A
Positive (forward) output current: (current mode)	limited to 0.1	A
Negative (reverse) output voltage: (-36V mode)	-36 +3/-10%	Vdc
Negative (reverse) output voltage: (-60V mode)	-60 +3/-10%	Vdc
Negative (reverse) output current:	max. 2.5	mA
Transition time: (50% input pulse \rightarrow 90% output voltage)	max. 3	us

Tune/Match Driver:

Output voltage: (DAC 0..4095, register A or B)	0..-30	Vdc
Trans. time reg. A to B: (50% input pulse \rightarrow 90% outp. volt.)	max. 6	us
Tune control output signals:	+5V TTL	--

RGP Output:

RGP output voltage:	+5V TTL	--
---------------------	---------	----

Coil Supply:

+9V output voltage: ($I_{Lmax} = 200mA$)	+9.0 \pm 0.5	Vdc
-30V output voltage: ($I_{Lmax} = 20mA$)	-30.0 \pm 0.5	Vdc
+5V output voltage: ($I_{Lmax} = 50mA$)	+5.0 \pm 0.5	Vdc

Figure 8.7. RF measurement paths

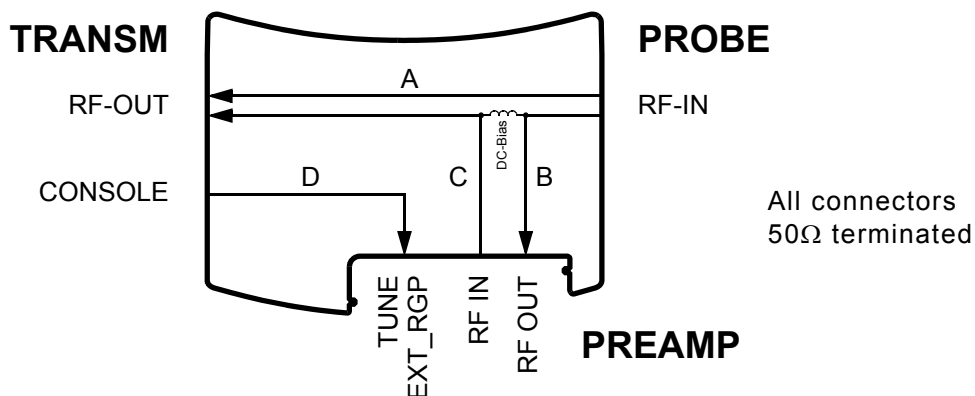

Insertion loss (S21): 0.005..0.5GHz / 0.5..1GHz

Path A:	max. 0.3 / 0.5	dB
Path B, C and D:	max. 0.6 / 1.0	dB

VSWR (S11): 0.005..1GHz

All connectors path A, B and C:	max. 1.2:1	-
All connectors path D:	max. 1.4:1	-

Isolation (S21): 0.005..1GHz

Path B → C and RF1 → RF2:	min. 35	dB
---------------------------	---------	----

Installation

8.6

The ADM module is designed to be at the bottom of the preamplifier module stack. It can be placed directly on the floor. No additional baseplate is needed.

Additional interface modules are placed below the ADM. In this case the large rubber feet must be removed before the modules are stacked on top of each other. The large rubber feet remain only on the bottom module.

Introduction

9.1

For service purpose BRUKER has developed an universal tool that allows access to boards with UniTool support for diagnostic, check and firmware upgrade over the RS485 serial bus.

UniTool acts as a browser, all menus are provided by the units themselves. Board specific UniTool access can be achieved by starting the UniTool with the matching SBSB address.

Identification of the firmware release

9.2

1. Open a UNIX shell or a command prompt window in the BRUKER Utilities folder when using Windows NT.
2. Start the UniTool from XWinNmr: `xwinnmr -e UniTool`
from TopSpin: `UniTool`
3. type `hppr`, confirm
4. type in the decimal address, master HPPR/2 is `80`, (for slave `81`), confirm
5. Select `[1] Show Version`, confirm

You will be given the details of firmware and boot software version.

Download a new HPPR/2 firmware

9.3

Please refer to the BRUKER Service Information to check out if a download is necessary.

! *The download of the most recent firmware is not always necessary. However, in case of trouble it is always recommended to download the most recent firmware available on the BBIO-CH ftp server.*

Further information about the demand of new firmware can also be found on the FTP server of BBIO-CH:

`ftp://ftp.bruker.ch/pub/NMR/download/servtools/firmware/hppr`

Download

9.3.1

Follow these instructions:

1. Check if the directory '**<your 'which UniTool' path>/conf/instr/servtool/UniTool/files/hppr**' exists. Otherwise create it.
2. Copy the most recent version available on the BBIO-CH ftp server (hppra_hex) into the directory '**<your 'which UniTool' path>/conf/instr/servtool/UniTool/files/hppr**'
3. Start UniTool in a Shell from XWinNmr: `xwinnmr -e UniTool`
from TopSpin: `UniTool`
4. -> hppr, confirm
5. -> decimal address for master HPPR/2 is 80, (slave 81), confirm
6. When the UniTool Menu is loaded, enter [A] Auto Download -> download starts. The download takes about 20..25 min
7. When download has finished, an error message like 'Communication error detected' may appear. This is an UniTool internal message and does not affect the download. Exit and restart UniTool. The HPPR/2 has to be accessible.

Error handling

9.3.2

If a serious malfunction occurs during download (e.g. network failures), the download can be restarted. The HPPR/2 automatically starts in **boot mode**, but UniTool operation is still provided.

```
host:user 1% xwinnmr -e UniTool hppr
Enter decimal SBSB address for hppr (80) > 80
device name taken from already existing configfile: /dev/tty10
B r u k e r  U n i T o o l
  Version: 1.0
  Compilation date: 010404
W A R N I N G:
  This is a hardware level debug tool.
  Improper operation may damage your hardware.
Connecting SBSB address 80 (0x50).
```

HPPR/2 ROM Menu	HPPR/2 ROM Menu
=====	=====
[0] Init HPPR/2	[1] Init HPPR/2
[1] Show Version	[2] Show Version
[A] Auto Download HPPR/2	[3] Check Download HPPR/2
[M] Manual Download HPPR/2	[4] Manual Download HPPR/2
[D] Show 'Diagnostic'- Menu	[5] Service...
[X] eXit Unitool	[Q] Exit
your choice: _	your choice: _

If a *power down* occurred while loading firmware the restart of the download is different. The red LED of the HPPR/2 in boot mode is blinking *fast*.

The download can be restarted with

[A] **Auto Download** Or [M] **Manual Download** respectively
[3] **Check Download** Or [4] **Manual Download** in older boot versions.

Index

Numerics

13C Module	48
13C-Module	36
15N Module	51
15N- Module	36
19F Module	69
1H HPLNA MODULE	45
1H2H Module	38, 69
1H-LNA Module	44
1H-Module	36
2H Module	37, 47
31P	36
3H Module	69
3H-Module	36

A

ADM	20, 82
air pressure	64
AQS address mapping	91
AQS PSM ADM	87
ATMA	20
ATMA/PICS	26
AUX	26
AUX POWER SUPPLY	26
AVANCE I-III	12

B

BIS	20, 30
boot mode	92

C

COM LED	22
Configuration with Cryoprobe	70
Configurations	67
Configurations for High Resolution	67
Connector Rear Side	26
CONTROL	26
Cover Module	21
CRP	20, 26
crp	24
Cryoprobe	70
CW	20

D

DC-Wiring DMX with HRD-16	14
DC-Wiring with AQS.....	12
dec	24
DMX	13
Download a new HPPR/2 firmware.....	91
DPX.....	13
DRX.....	13

E

Emergency stop	24
EMERGENCY_STOP	31
Error handling.....	92
ERROR LED	22

F

FAQs	17
forward power	24
FTP server	91
Fuse	13
Fuses	28
fwd pwr.....	24

H

High Power.....	70
HPHP 19F/1H and XBB/1P Module	40
HPHP/1 19F/1H Module.....	55
HPHP/2 19F/1H Module.....	55
HPHP/2 19F/1H MODULE Technical Data	60
HPHP/2 Modules.....	70
HPHP/2 XBB31P Module.....	56
HPHP/2 XBB31P MODULE Technical Data	60
HPLNA	20
HPLNA 1H.....	70
HPLNA 1H Module.....	41
HPPR/2	20
HPPR/2 13C MODULE Technical Data	59
HPPR/2 15N MODULE Technical Data	59
HPPR/2 1H LNA MODULE Technical Data	57 – 58
HPPR/2 2H MODULE Technical Data	58
HPPR/2 HPLNA 1H MODULE	57
HPPR/2 MRI ACTIVE DETUNING Module	82
HPPR/2 MRI-INTERFACE MODULE.....	74
HPPR/2 QNP Module.....	63
HPPR/2 XBB19F 2HS MODULE Technical Data	59
HPPR/2 XBB31P 2HS MODULE Technical Data	60

I

I2C.....	20
IFB.....	20
IFB (Interface Board).....	63
INTERLEAVE_INCR.....	20, 29

L

LCD.....	20
LED States.....	34
lock.....	24
LOCK_PP.....	20, 29

M

MATCHING LED.....	22
MDR.....	20
MRI ACTIVE DETUNING MODULE.....	81
MRI Interface Module Configurations.....	77
MRI Interface Module Wiring.....	77 – 78
MRI-INTERFACE MODULE.....	73, 81

O

obs.....	24
----------	----

P

PICS.....	20
PIN Driver.....	83
PLD.....	20
Pneumatic Switch Drive.....	65
power down.....	92
power fail error.....	34
Power Supply and Monitoring.....	28
Preamplifier Modules.....	35
PSM ADM.....	87
pwr err.....	24

Q

QNP.....	20
QNP Module.....	61

R

READY LED.....	22
Real-Time Pulse.....	29
refl pwr.....	24
reflected power.....	24
reflectometer.....	24

RGP Output.....	84
RGP_HPPR	20, 29
RGP_PA.....	20
ROM Menu.....	92
RS485 addresses in AQS	91
 S	
SBSB.....	20
SBSB addresses in AQS.....	91
SGU firmware release, identification.....	91
SLEEP LED.....	22
stop	24
 T	
Technical Specifications.....	57
TP_F	29
TP_F0	12, 20
Tune/Match Driver.....	84
TUNING LED	22
Tuning with DRX, DPX and DMX.....	13
two XBB Module.....	68
 U	
UniTool.....	91
 V	
Valve	64
 W	
Wiring	12
wobb.....	24
 X	
XBB-19F 2HS Module.....	52
XBB-19F 2HS Module 500-700.....	53
XBB-31P 2HS Module.....	54
X-BB-Module.....	36

Bruker BioSpin **your solution partner**

Bruker BioSpin provides a world class, market-leading range of analysis solutions for your life and materials science needs

● **Bruker BioSpin Group**

info@bruker-biospin.com
www.bruker-biospin.com