

AQR

**Amplitude Setting Unit 1
Technical Manual**

Version 005

BRUKER

The information in this manual may be altered without notice.

BRUKER accepts no responsibility for actions taken as a result of use of this manual. BRUKER accepts no liability for any mistakes contained in the manual, leading to coincidental damage, whether during installation or operation of the instrument. Unauthorised reproduction of manual contents, without written permission from the publishers, or translation into another language, either in full or in part, is forbidden.

This manual was written by

BARTHÉLÉMY Philippe

© October 28, 1998: Bruker SA

Wissembourg, France

Manual P/N: Z31232

DWG-Nr: 903005

Contents

	Contents	3
	Index	5
1	ASU 1 Channel.....	7
2	Interface.....	11
2.1	Inputs / Ouputs Connectors	17
3	MMA Unit.....	19
4	Specifications	33
4.1	Characteristics of Amplitude Setting Unit 1 Channel	33
	RF specifications	33
	Dynamics	33
	Phase shift	33
	Isolation (SPENAB CMD)	33
	Output noise level	34
	Switching time	34
	DC requirements	34
	Operating temperature	34
	Figures	35
	Tables	37

Index

W

W4B131470 C.....	9
W4B132717 A.....	20
W4D132104	14
W4L131102 B	30
W4L131372 A	22
W4L131375 B	26
W4L131472 C	8
W4L132197.....	13
W4S131372 A.....	21
W4S131375 B.....	25
W4S132081	29
W4S132197	12
W4W131471 C.....	10

ASU 1 Channel

1

Figure 1.1. Amplitude Setting Unit 1 Channel Location

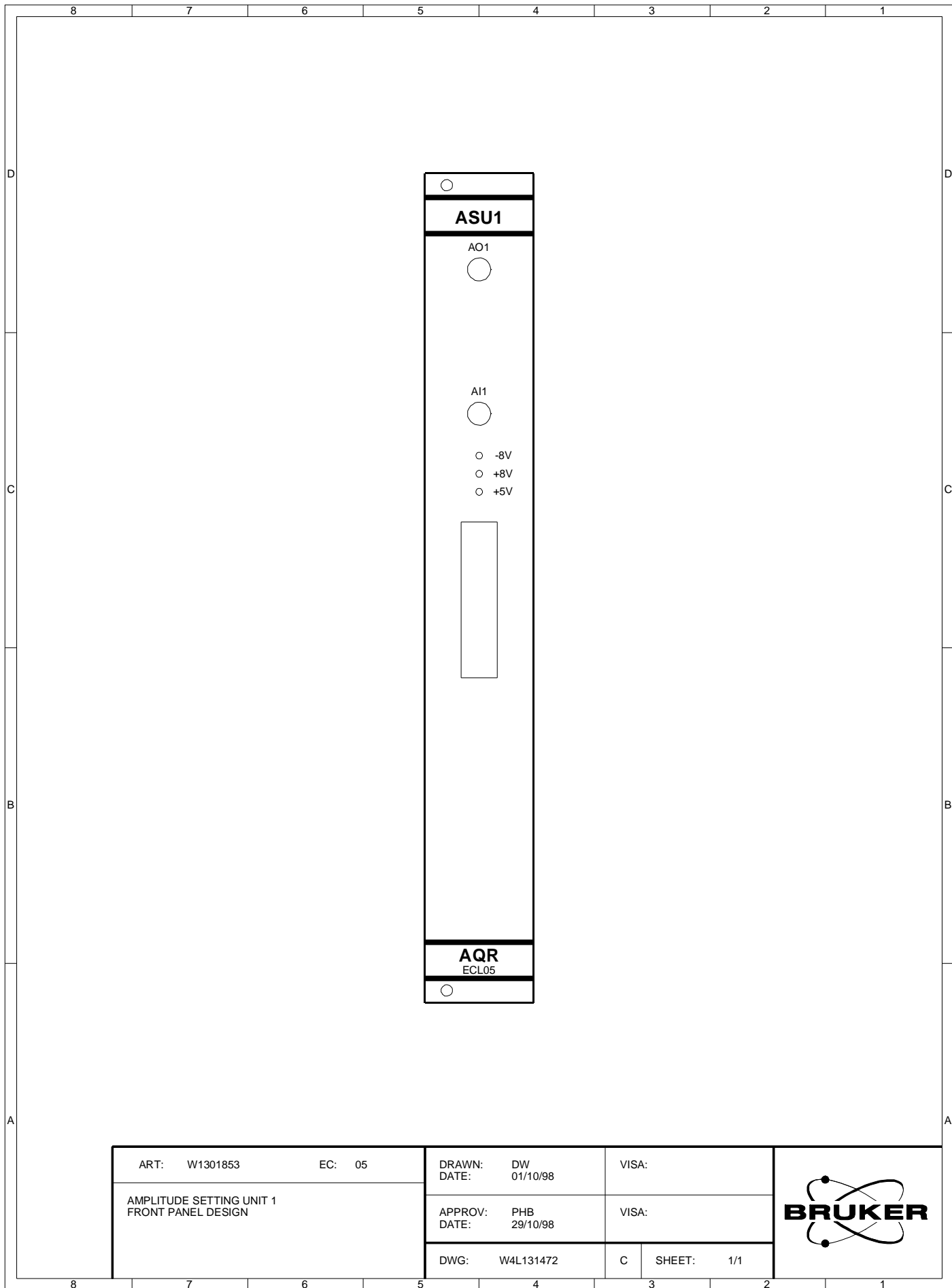
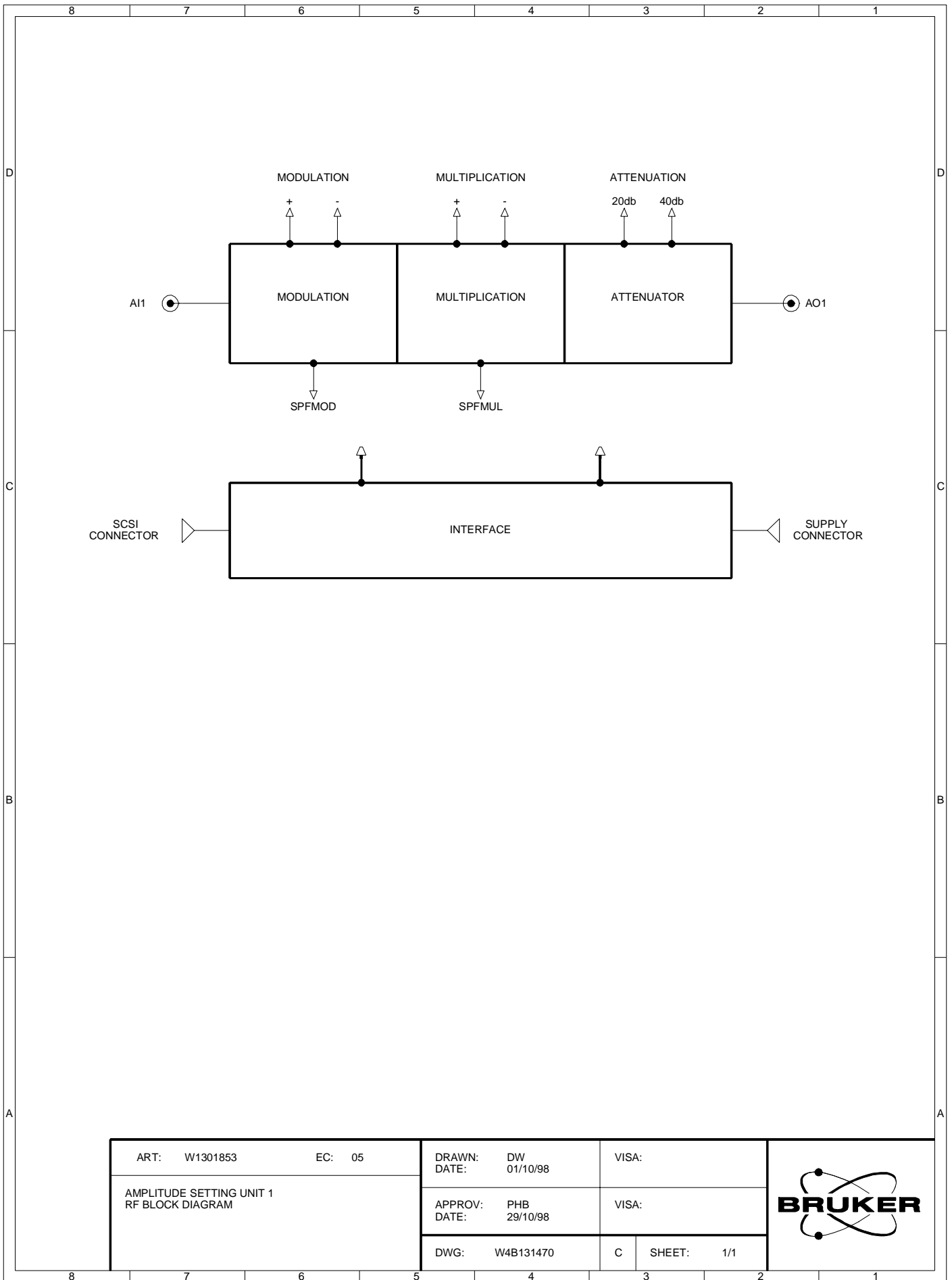

Figure 1.2. Amplitude Setting Unit 1 Channel Block Diagram



ART: W1301853	EC: 05	DRAWN: DW	VISA:
AMPLITUDE SETTING UNIT 1 RF BLOCK DIAGRAM		DATE: 01/10/98	
		APPROV: PHB	VISA:
		DATE: 29/10/98	
DWG: W4B131470		C	SHEET: 1/1



Figure 1.3. Amplitude Setting Unit 1 Channel Wiring Diagram

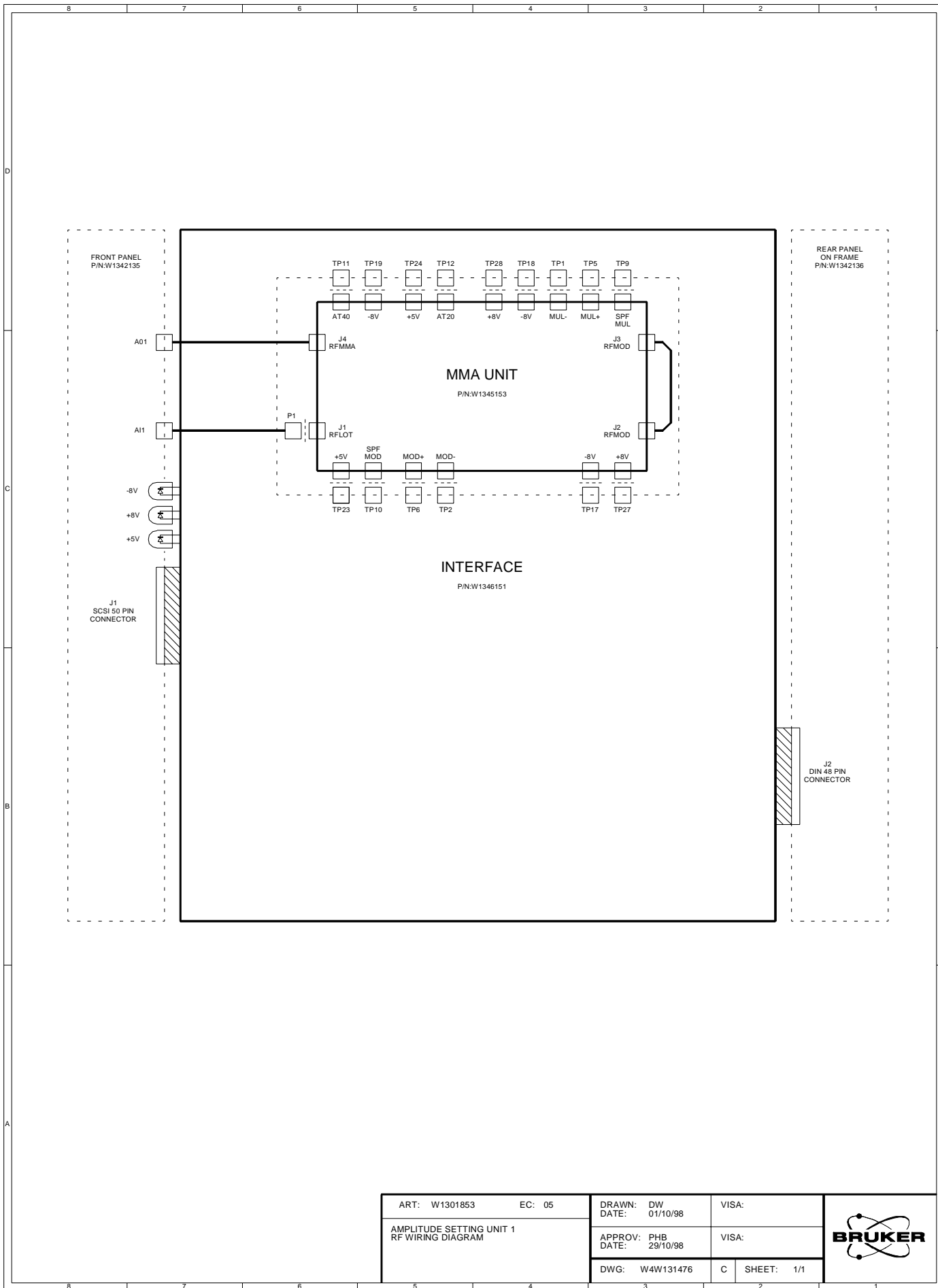

ART: W1301853	EC: 05	DRAWN: DW DATE: 01/10/98	VISA:
AMPLITUDE SETTING UNIT 1 RF WIRING DIAGRAM		APPROV: PHB DATE: 29/10/98	VISA:
		DWG: W4W131476	C SHEET: 1/1



Interface

2

Figure 2.1. Interface Schematic

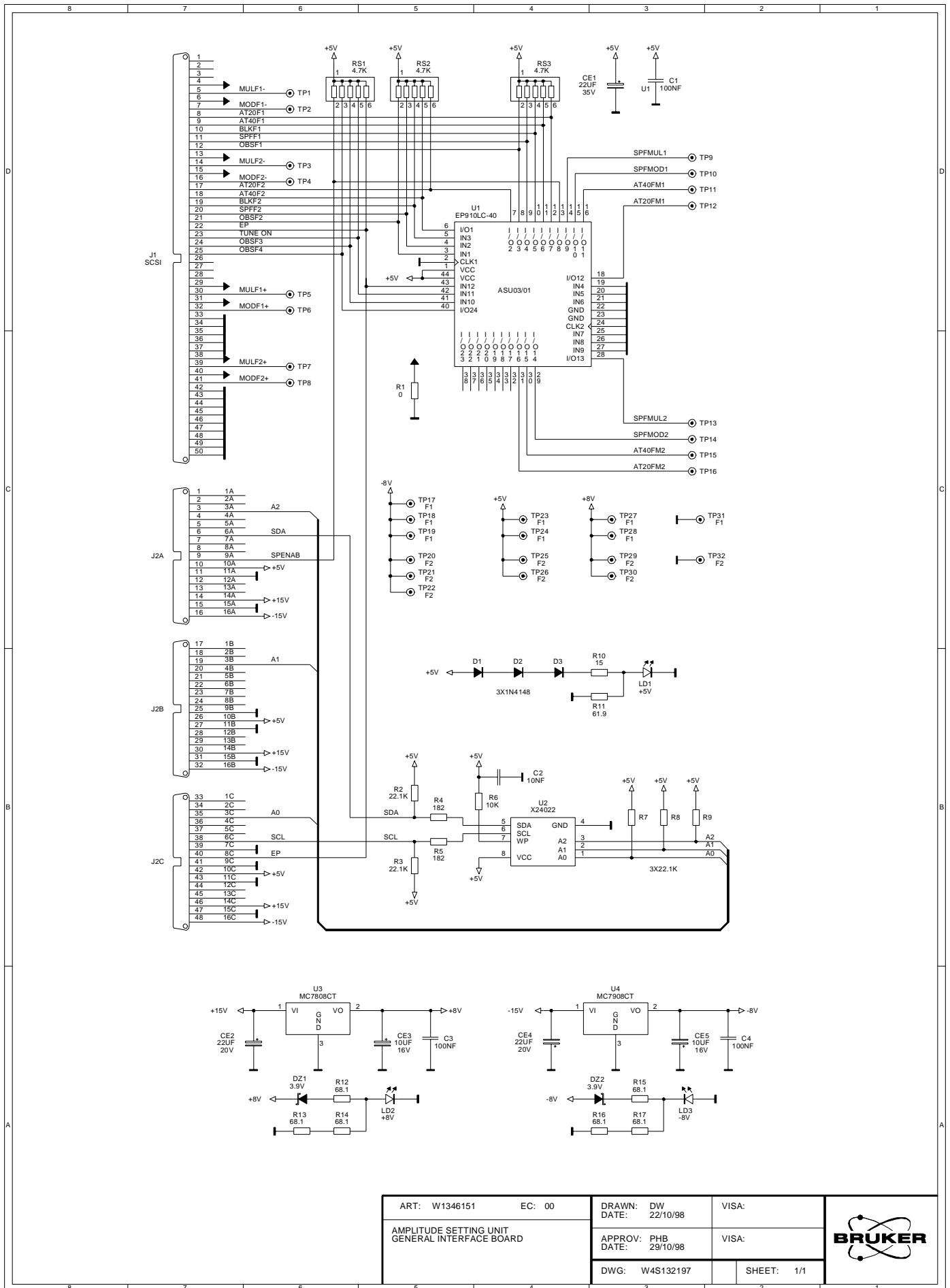

ART: W1346151	EC: 00	DRAWN: DW DATE: 22/10/98	VISA:
AMPLITUDE SETTING UNIT GENERAL INTERFACE BOARD		APPROV: PHB DATE: 29/10/98	VISA:
		DWG: W4S132197	SHEET: 1/1



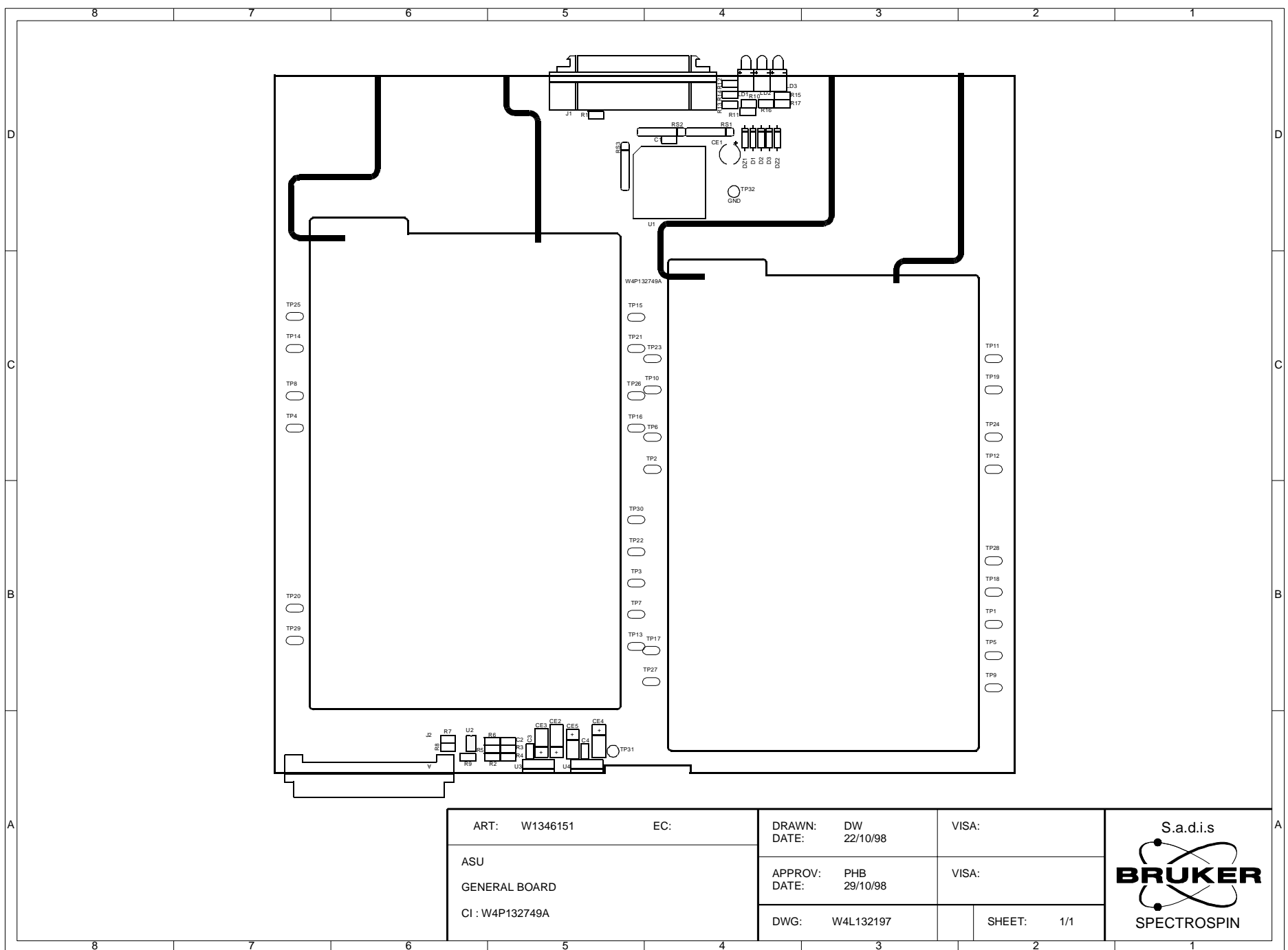

Figure 2.2. Interface Location

ART: W1346151	EC:
ASU	
GENERAL BOARD	
CI : W4P132749A	

DRAWN: DW	VISA:
DATE: 22/10/98	
APPROV: PHB	VISA:
DATE: 29/10/98	
DWG: W4L132197	SHEET: 1/1

S.a.d.i.s	
BRUKER	
SPECTROSPIN	

Value Table

+-- Value Tab Head -----+			
Part:W1346151 Drawing:W4S132197		Copy In Part:	
Desc:AQR ASU CIRCUIT INTERFACE		ECL:0	Draw: Modified:22/10/98 By:DW
+-- Value Tab -----+			
Pos.	Component	Local Description	
C1	8493	COND CMS 1206 100N 50V 20% X7R	
C2	21014	COND CMS 1206 10N 50V 20% X7R	
C3	8493	COND CMS 1206 100N 50V 20% X7R	
C4	8493	COND CMS 1206 100N 50V 20% X7R	
CE1	10017	COND CHIMI RAD 22U 35V 6.3X7	
CE2	51557	COND CMS TANTAL 22U 20V 20%	
CE3	51559	COND CMS TANTAL 10U 16V 20%	
CE4	51557	COND CMS TANTAL 22U 20V 20%	
CE5	51559	COND CMS TANTAL 10U 16V 20%	
CI1	W1348018	CI ASU2/LOT CIRCUIT INTERFACE	
D1	2967	DIODE 1N4148	
D2	2967	DIODE 1N4148	
D3	2967	DIODE 1N4148	
DZ1	34639	DIODE Z BZX55C 3.9V 500MW	
DZ2	34639	DIODE Z BZX55C 3.9V 500MW	
ICSU1	15771	IC SUPPORT PLCC44	
J1	59837	CN F 50 C PRT SCSI/1.27	
J2	22744	CN M 48 C PRT DIN41612-C/2	
LD1	21866	OPTO LED 3MM C PRT BOI VR R2.5	
LD2	21866	OPTO LED 3MM C PRT BOI VR R2.5	
LD3	21866	OPTO LED 3MM C PRT BOI VR R2.5	
R1	21352	RES CMS 0 1% 0.25W 1206	
R2	21327	RES CMS 22.1K 1% 0.25W 1206	
R3	21327	RES CMS 22.1K 1% 0.25W 1206	
R4	20727	RES CMS 182 1% 0.25W 1206	
R5	20727	RES CMS 182 1% 0.25W 1206	
R6	20750	RES CMS 10K 1% 0.25W 1206	
R7	21327	RES CMS 22.1K 1% 0.25W 1206	
R8	21327	RES CMS 22.1K 1% 0.25W 1206	
R9	21327	RES CMS 22.1K 1% 0.25W 1206	
R10	20713	RES CMS 15 1% 0.25W 1206	
R11	8853	RES CMS 61.9 1% 0.25W 1206	
R12	20721	RES CMS 68.1 1% 0.25W 1206	
R13	20721	RES CMS 68.1 1% 0.25W 1206	
R14	20721	RES CMS 68.1 1% 0.25W 1206	
R15	20721	RES CMS 68.1 1% 0.25W 1206	
R16	20721	RES CMS 68.1 1% 0.25W 1206	
R17	20721	RES CMS 68.1 1% 0.25W 1206	
RS1	9818	RES RES 4.7KX5 2% SIL6	
RS2	9818	RES RES 4.7KX5 2% SIL6	
RS3	9818	RES RES 4.7KX5 2% SIL6	
TP1	35779	ACCBL LANGUETTE PL 2.8 PRT	
TP2	35779	ACCBL LANGUETTE PL 2.8 PRT	
TP3	35779	ACCBL LANGUETTE PL 2.8 PRT	
TP4	35779	ACCBL LANGUETTE PL 2.8 PRT	
TP5	35779	ACCBL LANGUETTE PL 2.8 PRT	
TP6	35779	ACCBL LANGUETTE PL 2.8 PRT	
TP7	35779	ACCBL LANGUETTE PL 2.8 PRT	
TP8	35779	ACCBL LANGUETTE PL 2.8 PRT	
TP9	35779	ACCBL LANGUETTE PL 2.8 PRT	
TP10	35779	ACCBL LANGUETTE PL 2.8 PRT	
TP11	35779	ACCBL LANGUETTE PL 2.8 PRT	
TP12	35779	ACCBL LANGUETTE PL 2.8 PRT	
TP13	35779	ACCBL LANGUETTE PL 2.8 PRT	

Interface

```

+-- Value Tab Head -----+
| Part:W1346151 Drawing:W4S132197          Copy In Part:          Draw:          |
| Desc:AQR ASU CIRCUIT INTERFACE          ECL:0          Modified:22/10/98      By:DW      |
+-- Value Tab -----+
| Pos.          Component          Local Description          |
| TP14          35779              ACCBL LANGUETTE PL 2.8 PRT |
| TP15          35779              ACCBL LANGUETTE PL 2.8 PRT |
| TP16          35779              ACCBL LANGUETTE PL 2.8 PRT |
| TP17          35779              ACCBL LANGUETTE PL 2.8 PRT |
| TP18          35779              ACCBL LANGUETTE PL 2.8 PRT |
| TP19          35779              ACCBL LANGUETTE PL 2.8 PRT |
| TP20          35779              ACCBL LANGUETTE PL 2.8 PRT |
| TP21          35779              ACCBL LANGUETTE PL 2.8 PRT |
| TP22          35779              ACCBL LANGUETTE PL 2.8 PRT |
| TP23          35779              ACCBL LANGUETTE PL 2.8 PRT |
| TP24          35779              ACCBL LANGUETTE PL 2.8 PRT |
| TP25          35779              ACCBL LANGUETTE PL 2.8 PRT |
| TP26          35779              ACCBL LANGUETTE PL 2.8 PRT |
| TP27          35779              ACCBL LANGUETTE PL 2.8 PRT |
| TP28          35779              ACCBL LANGUETTE PL 2.8 PRT |
| TP29          35779              ACCBL LANGUETTE PL 2.8 PRT |
| TP30          35779              ACCBL LANGUETTE PL 2.8 PRT |
| TP31          59995              ACCBL PICOT FOURCHE D1.1MM |
| TP32          59995              ACCBL PICOT FOURCHE D1.1MM |
| TP3           35779              ACCBL LANGUETTE PL 2.8 PRT |
| TP4           35779              ACCBL LANGUETTE PL 2.8 PRT |
| TP5           35779              ACCBL LANGUETTE PL 2.8 PRT |
| TP6           35779              ACCBL LANGUETTE PL 2.8 PRT |
| TP7           35779              ACCBL LANGUETTE PL 2.8 PRT |
| TP8           35779              ACCBL LANGUETTE PL 2.8 PRT |
| TP9           35779              ACCBL LANGUETTE PL 2.8 PRT |
| U1            W1356607          IC 910/ASU CIRCUIT INTERFACE |
| U2            22952              IC 24022/E2PR X24022S8 SO8   |
| U3            4978                IC 7808/VREG MC7808CT TO220  |
| U4            12156              IC 7908/VREG MC7908CT TO220  |
+-----+

```

Table 2.1. Front Panel Connector J1

Pins	Descriptions	Pins	Descriptions
01	NC	26	NC
02	NC	27	NC
03	NC	28	NC
04	AGND	29	AGND
05	MULF1-	30	MULF1+
06	AGND	31	AGND
07	MODF1-	32	MODF1+
08	AT20F1	33	DGND
09	AT40F1	34	DGND
10	BLKF1	35	DGND
11	SPFF1	36	DGND
12	OBSF1	37	DGND
13	AGND	38	AGND
14	MULF2-	39	MULF2+
15	AGND	40	AGND
16	MODF2-	41	MODF2+
17	AT20F2	42	DGND
18	AT40F2	43	DGND
19	BLKF2	44	DGND
20	SPFF2	45	DGND
21	OBSF2	46	DGND
22	NC	47	DGND
23	TUNE ON	48	DGND
24	NC	49	DGND
25	NC	50	DGND

Table 2.2. Rear Panel Connector J2

Pins	Descriptions	Pins	Descriptions	Pins	Descriptions
1A	NC	1B	NC	1C	NC
2A	NC	2B	NC	2C	NC
3A	Adresse 1	3B	Adresse 2	3C	Adresse 3
4A	NC	4B	NC	4C	NC
5A	NC	5B	NC	5C	NC
6A	SDA	6B	NC	6C	SCL
7A	NC	7B	NC	7C	I2CGND
8A	NC	8B	NC	8C	EP
9A	SPENAB	9B	SPENABGND	9C	EPGND
10A	+5V	10B	+5V	10C	+5V
11A	GND	11B	GND	11C	GND
12A	NC	12B	NC	12C	NC
13A	NC	13B	NC	13C	NC
14A	+15V	14B	+15V	14C	+15V
15A	GND	15B	GND	15C	GND
16A	-15V	16B	-15V	16C	-15V

MMA Unit

3

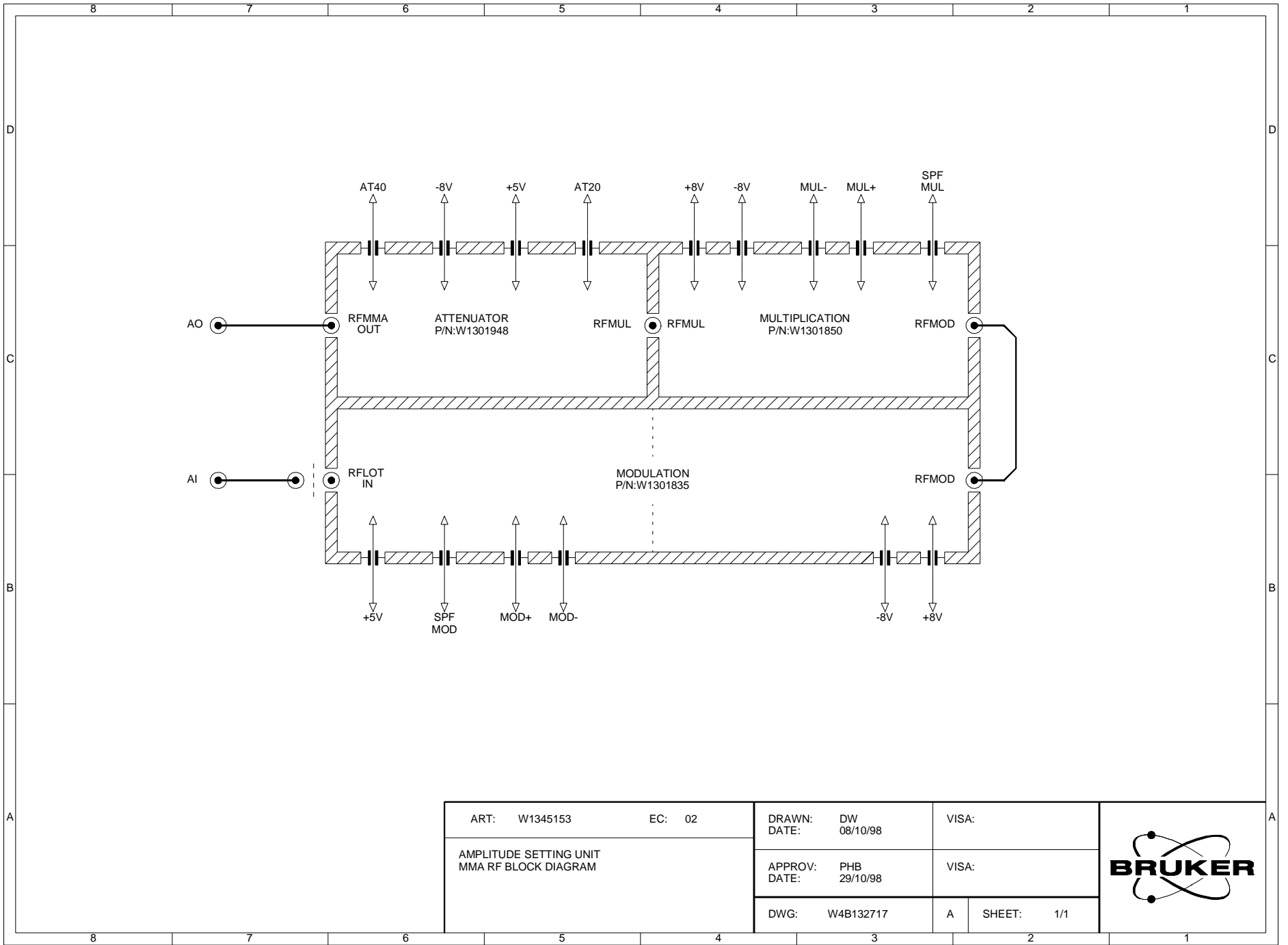
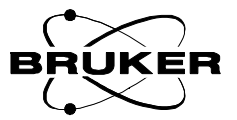

Figure 3.1. Modulation, Multiplication & Attenuator Block Diagram

ART: W1345153	EC: 02	DRAWN: DW	VISA:
AMPLITUDE SETTING UNIT MMA RF BLOCK DIAGRAM		DATE: 08/10/98	
		APPROV: PHB	VISA:
		DATE: 29/10/98	
		DWG: W4B132717	A SHEET: 1/1



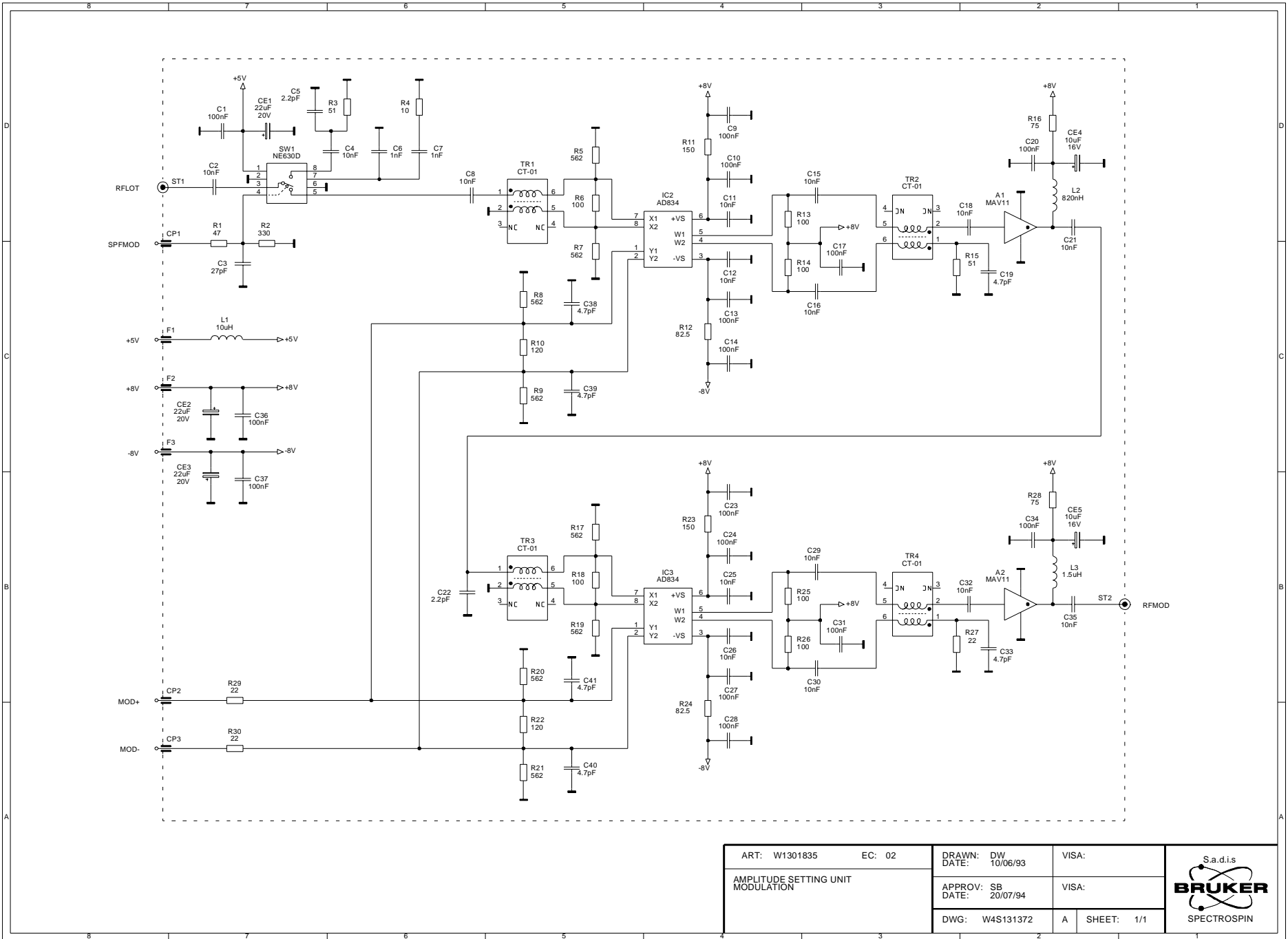

Figure 3.2. Modulation Schematic

ART: W1301835	EC: 02	DRAWN: DW DATE: 10/06/93	VISA:	
AMPLITUDE SETTING UNIT MODULATION		APPROV: SB DATE: 20/07/94	VISA:	
		DWG: W4S131372	A SHEET: 1/1	

Value Table

Value Tab Head			
Part:W1301835 Drawing:W4S131372A		Copy In Part:	
Desc:ASU MODULATION		ECL:2	Modified:13/05/98
			Draw: By:MN
Value Tab			
Pos.	Component	Local Description	
A1	31201	IC 11/HF MAV-11	
A2	31201	IC 11/HF MAV-11	
C1	8493	COND CMS 1206 100N 50V 20% X7R	
C2	21014	COND CMS 1206 10N 50V 20% X7R	
C3	73182	COND CMS CDR12 27P 150V 20%	
C4	21014	COND CMS 1206 10N 50V 20% X7R	
C5	73179	COND CMS CDR12 2.2P 150V 0.25P	
C6	73183	COND CMS CDR12 1N 150V 20%	
C7	73183	COND CMS CDR12 1N 150V 20%	
C8	21014	COND CMS 1206 10N 50V 20% X7R	
C9	8493	COND CMS 1206 100N 50V 20% X7R	
C10	8493	COND CMS 1206 100N 50V 20% X7R	
C11	21014	COND CMS 1206 10N 50V 20% X7R	
C12	21014	COND CMS 1206 10N 50V 20% X7R	
C13	8493	COND CMS 1206 100N 50V 20% X7R	
C14	8493	COND CMS 1206 100N 50V 20% X7R	
C15	21014	COND CMS 1206 10N 50V 20% X7R	
C16	21014	COND CMS 1206 10N 50V 20% X7R	
C17	8493	COND CMS 1206 100N 50V 20% X7R	
C18	21014	COND CMS 1206 10N 50V 20% X7R	
C19	73180	COND CMS CDR12 4.7P 150V 0.25P	
C20	8493	COND CMS 1206 100N 50V 20% X7R	
C21	21014	COND CMS 1206 10N 50V 20% X7R	
C22	73179	COND CMS CDR12 2.2P 150V 0.25P	
C23	8493	COND CMS 1206 100N 50V 20% X7R	
C24	8493	COND CMS 1206 100N 50V 20% X7R	
C25	21014	COND CMS 1206 10N 50V 20% X7R	
C26	21014	COND CMS 1206 10N 50V 20% X7R	
C27	8493	COND CMS 1206 100N 50V 20% X7R	
C28	8493	COND CMS 1206 100N 50V 20% X7R	
C29	21014	COND CMS 1206 10N 50V 20% X7R	
C30	21014	COND CMS 1206 10N 50V 20% X7R	
C31	8493	COND CMS 1206 100N 50V 20% X7R	
C32	21014	COND CMS 1206 10N 50V 20% X7R	
C33	73180	COND CMS CDR12 4.7P 150V 0.25P	
C34	8493	COND CMS 1206 100N 50V 20% X7R	
C35	21014	COND CMS 1206 10N 50V 20% X7R	
C36	8493	COND CMS 1206 100N 50V 20% X7R	
C37	8493	COND CMS 1206 100N 50V 20% X7R	
C38	73180	COND CMS CDR12 4.7P 150V 0.25P	
C39	73180	COND CMS CDR12 4.7P 150V 0.25P	
C40	73180	COND CMS CDR12 4.7P 150V 0.25P	
C41	73180	COND CMS CDR12 4.7P 150V 0.25P	
CE1	51557	COND CMS TANTAL 22U 20V 20%	
CE2	51557	COND CMS TANTAL 22U 20V 20%	
CE3	51557	COND CMS TANTAL 22U 20V 20%	
CE4	51559	COND CMS TANTAL 10U 16V 20%	
CE5	51559	COND CMS TANTAL 10U 16V 20%	
CI1	W1356256	CI ASU MODULATION	
IC2	56416	IC 834/PAD AD834 MULT 500MHZ	
IC3	56416	IC 834/PAD AD834 MULT 500MHZ	
L1	30155	SELF 10UH 0.14A	
L2	56430	SELF CMS 1008 820NH 10%	
L3	22874	SELF CMS 1008 1.5UH 10%	

MMA Unit

Value Tab Head		
Part:W1301835	Drawing:W4S131372A	Copy In Part:
Desc:ASU MODULATION	ECL:2	Modified:13/05/98
Value Tab		Draw: By:MN
Pos.	Component	Local Description
R1	73283	RES CMS 47.5 1% 0.25W 1206
R2	20730	RES CMS 332 1% 0.25W 1206
R3	20765	RES CMS 51.1 1% 0.25W 1206
R4	20711	RES CMS 10 1% 0.25W 1206
R5	20733	RES CMS 562 1% 0.25W 1206
R6	20724	RES CMS 100 1% 0.25W 1206
R7	20733	RES CMS 562 1% 0.25W 1206
R8	20733	RES CMS 562 1% 0.25W 1206
R9	20733	RES CMS 562 1% 0.25W 1206
R10	20725	RES CMS 121 1% 0.25W 1206
R11	20726	RES CMS 150 1% 0.25W 1206
R12	20722	RES CMS 82.5 1% 0.25W 1206
R13	20724	RES CMS 100 1% 0.25W 1206
R14	20724	RES CMS 100 1% 0.25W 1206
R15	20765	RES CMS 51.1 1% 0.25W 1206
R16	51836	RES CMS 75 1% 0.25W 1206
R17	20733	RES CMS 562 1% 0.25W 1206
R18	20724	RES CMS 100 1% 0.25W 1206
R19	20733	RES CMS 562 1% 0.25W 1206
R20	20733	RES CMS 562 1% 0.25W 1206
R21	20733	RES CMS 562 1% 0.25W 1206
R22	20725	RES CMS 121 1% 0.25W 1206
R23	20726	RES CMS 150 1% 0.25W 1206
R24	20722	RES CMS 82.5 1% 0.25W 1206
R25	20724	RES CMS 100 1% 0.25W 1206
R26	20724	RES CMS 100 1% 0.25W 1206
R27	20715	RES CMS 22.1 1% 0.25W 1206
R28	51836	RES CMS 75 1% 0.25W 1206
R29	990	RES MET 22.1 1% 0.6W 50PPM
R30	990	RES MET 22.1 1% 0.6W 50PPM
ST1	33011	CN COAX SMA F D EMB PLATINE
ST2	33011	CN COAX SMA F D EMB PLATINE
SW1	56425	IC 630/SA630 S08
TR1	56414	TRSFO 1/1 5-1000MHZ CMS DIP6
TR2	56414	TRSFO 1/1 5-1000MHZ CMS DIP6
TR3	56414	TRSFO 1/1 5-1000MHZ CMS DIP6
TR4	56414	TRSFO 1/1 5-1000MHZ CMS DIP6

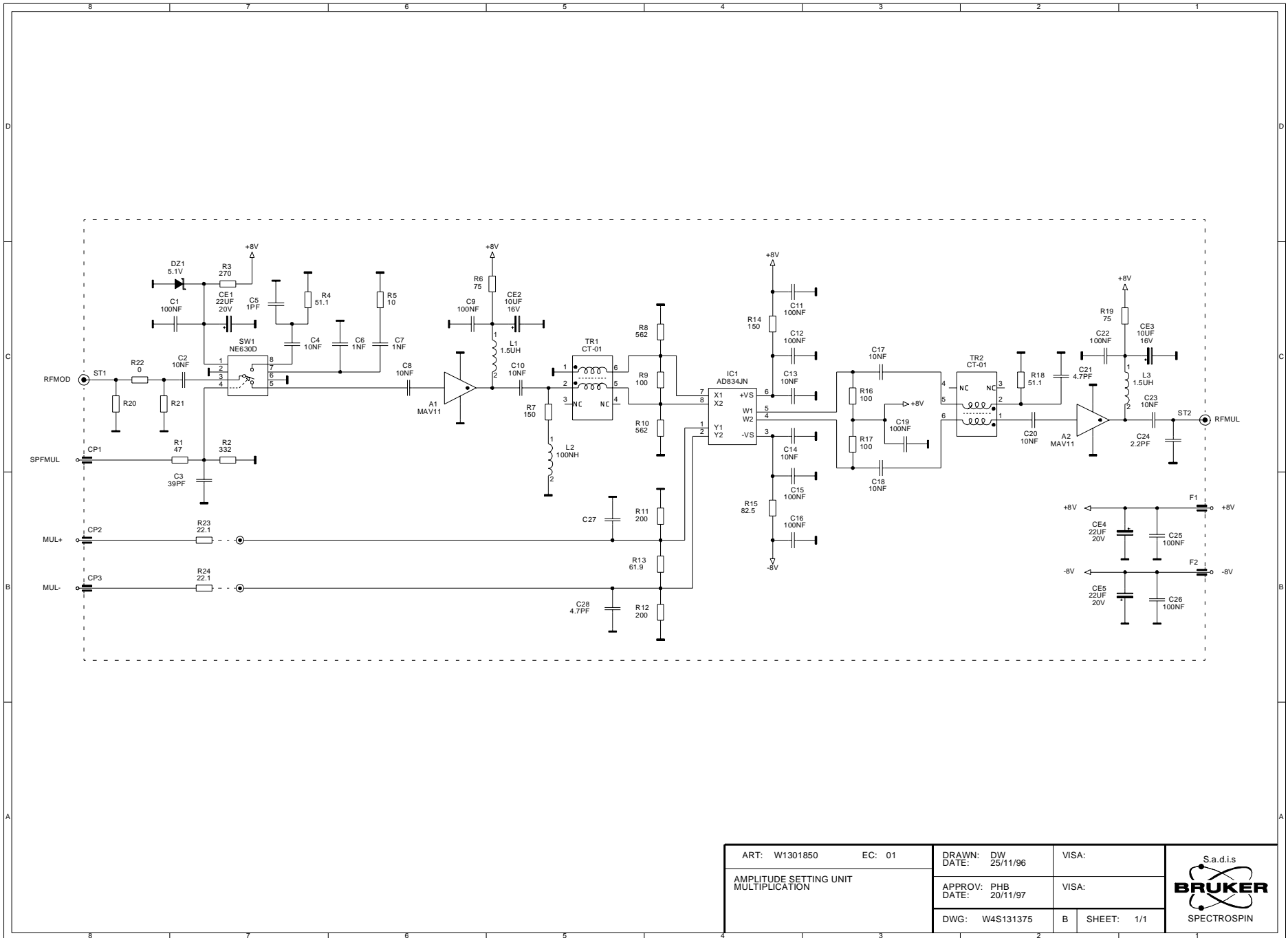
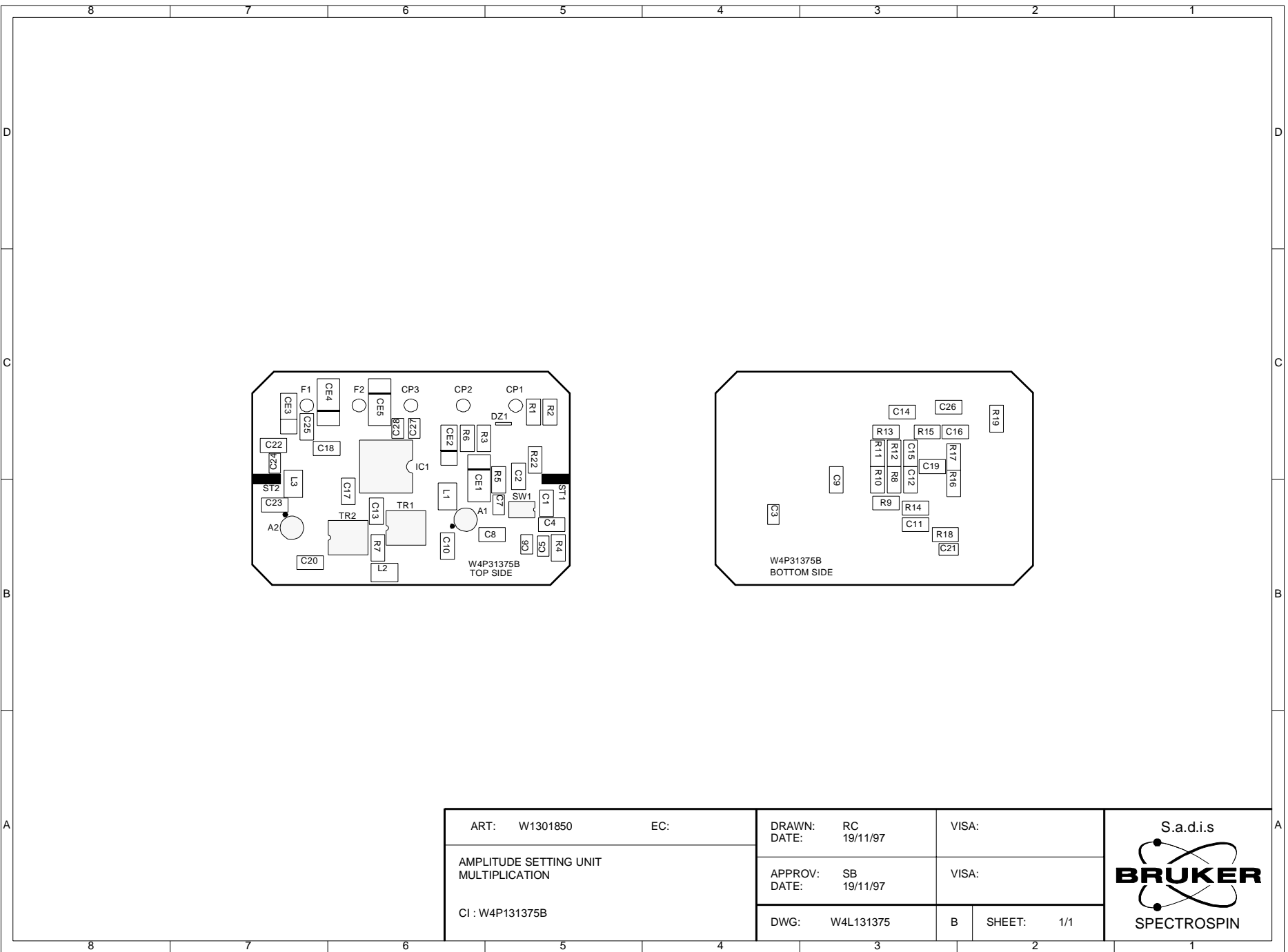

Figure 3.4. Multiplication Schematic

ART: W1301850	EC: 01	DRAWN: DW DATE: 25/11/96	VISA:	
AMPLITUDE SETTING UNIT MULTIPLICATION		APPROV: PHB DATE: 20/11/97	VISA:	
		DWG: W4S131375	B SHEET: 1/1	

Figure 3.5. Multiplication Location



Value Table

+-- Value Tab Head -----+			
Part:W1301850 Drawing:W4S131375B		Copy In Part:	
Desc:ASU MULTIPLICATION		ECL:1	Modified:03/08/98
		Draw:	
		By:MN	
+-- Value Tab -----+			
Pos.	Component	Local Description	
A1	31201	IC 11/HF MAV-11	
A2	31201	IC 11/HF MAV-11	
C1	8493	COND CMS 1206 100N 50V 20% X7R	
C2	21014	COND CMS 1206 10N 50V 20% X7R	
C3	73409	COND CMS CDR12 39P 150V 20%	
C4	21014	COND CMS 1206 10N 50V 20% X7R	
C5	73410	COND CMS CDR12 1P 150V 0.25P	
C6	73183	COND CMS CDR12 1N 150V 20%	
C7	73183	COND CMS CDR12 1N 150V 20%	
C8	21014	COND CMS 1206 10N 50V 20% X7R	
C9	8493	COND CMS 1206 100N 50V 20% X7R	
C10	21014	COND CMS 1206 10N 50V 20% X7R	
C11	8493	COND CMS 1206 100N 50V 20% X7R	
C12	8493	COND CMS 1206 100N 50V 20% X7R	
C13	21014	COND CMS 1206 10N 50V 20% X7R	
C14	21014	COND CMS 1206 10N 50V 20% X7R	
C15	8493	COND CMS 1206 100N 50V 20% X7R	
C16	8493	COND CMS 1206 100N 50V 20% X7R	
C17	21014	COND CMS 1206 10N 50V 20% X7R	
C18	21014	COND CMS 1206 10N 50V 20% X7R	
C19	8493	COND CMS 1206 100N 50V 20% X7R	
C20	21014	COND CMS 1206 10N 50V 20% X7R	
C21	73180	COND CMS CDR12 4.7P 150V 0.25P	
C22	8493	COND CMS 1206 100N 50V 20% X7R	
C23	21014	COND CMS 1206 10N 50V 20% X7R	
C24	73179	COND CMS CDR12 2.2P 150V 0.25P	
C25	8493	COND CMS 1206 100N 50V 20% X7R	
C26	8493	COND CMS 1206 100N 50V 20% X7R	
C28	73180	COND CMS CDR12 4.7P 150V 0.25P	
CE1	51557	COND CMS TANTAL 22U 20V 20%	
CE2	51559	COND CMS TANTAL 10U 16V 20%	
CE3	51559	COND CMS TANTAL 10U 16V 20%	
CE4	51557	COND CMS TANTAL 22U 20V 20%	
CE5	51557	COND CMS TANTAL 22U 20V 20%	
CI1	W1356257	CI ASU MULTIPLICATION	
CP1	59995	ACCBL PICOT FOURCHE D1.1MM	
DZ1	22577	DIODE Z BZX84C 5V1 300MW SOT23	
F1	59995	ACCBL PICOT FOURCHE D1.1MM	
F2	59995	ACCBL PICOT FOURCHE D1.1MM	
IC1	56416	IC 834/PAD AD834 MULT 500MHZ	
L1	22874	SELF CMS 1008 1.5UH 10%	
L2	22779	SELF CMS 1008 100NH 10%	
L3	22874	SELF CMS 1008 1.5UH 10%	
R1	73283	RES CMS 47.5 1% 0.25W 1206	
R2	20730	RES CMS 332 1% 0.25W 1206	
R3	53689	RES CMS 274 1% 0.25W 1206	
R4	20765	RES CMS 51.1 1% 0.25W 1206	
R5	20711	RES CMS 10 1% 0.25W 1206	
R6	51836	RES CMS 75 1% 0.25W 1206	
R7	20726	RES CMS 150 1% 0.25W 1206	
R8	20733	RES CMS 562 1% 0.25W 1206	
R9	20724	RES CMS 100 1% 0.25W 1206	
R10	20733	RES CMS 562 1% 0.25W 1206	
R11	8854	RES CMS 200 1% 0.25W 1206	

MMA Unit

```
+-- Value Tab Head -----+
| Part:W1301850 Drawing:W4S131375B          Copy In Part:      Draw:      |
| Desc:ASU MULTIPLICATION                    ECL:1             Modified:03/08/98    By:MN      |
+-- Value Tab -----+
|      Pos.      Component      Local Description      |
|      R12      8854            RES CMS 200 1% 0.25W 1206 |
|      R13      8853            RES CMS 61.9 1% 0.25W 1206 |
|      R14      20726           RES CMS 150 1% 0.25W 1206 |
|      R15      20722           RES CMS 82.5 1% 0.25W 1206 |
|      R16      20724           RES CMS 100 1% 0.25W 1206 |
|      R17      20724           RES CMS 100 1% 0.25W 1206 |
|      R18      20765           RES CMS 51.1 1% 0.25W 1206 |
|      R19      51836           RES CMS 75 1% 0.25W 1206   |
|      R22      21352           RES CMS 0 1% 0.25W 1206    |
|      R23      990             RES MET 22.1 1% 0.6W 50PPM |
|      R24      990             RES MET 22.1 1% 0.6W 50PPM |
|      SW1      56425           IC 630/SA630 S08           |
|      TR1      56414           TRSFO 1/1 5-1000MHZ CMS DIP6 |
|      TR2      56414           TRSFO 1/1 5-1000MHZ CMS DIP6 |
+-----+
```

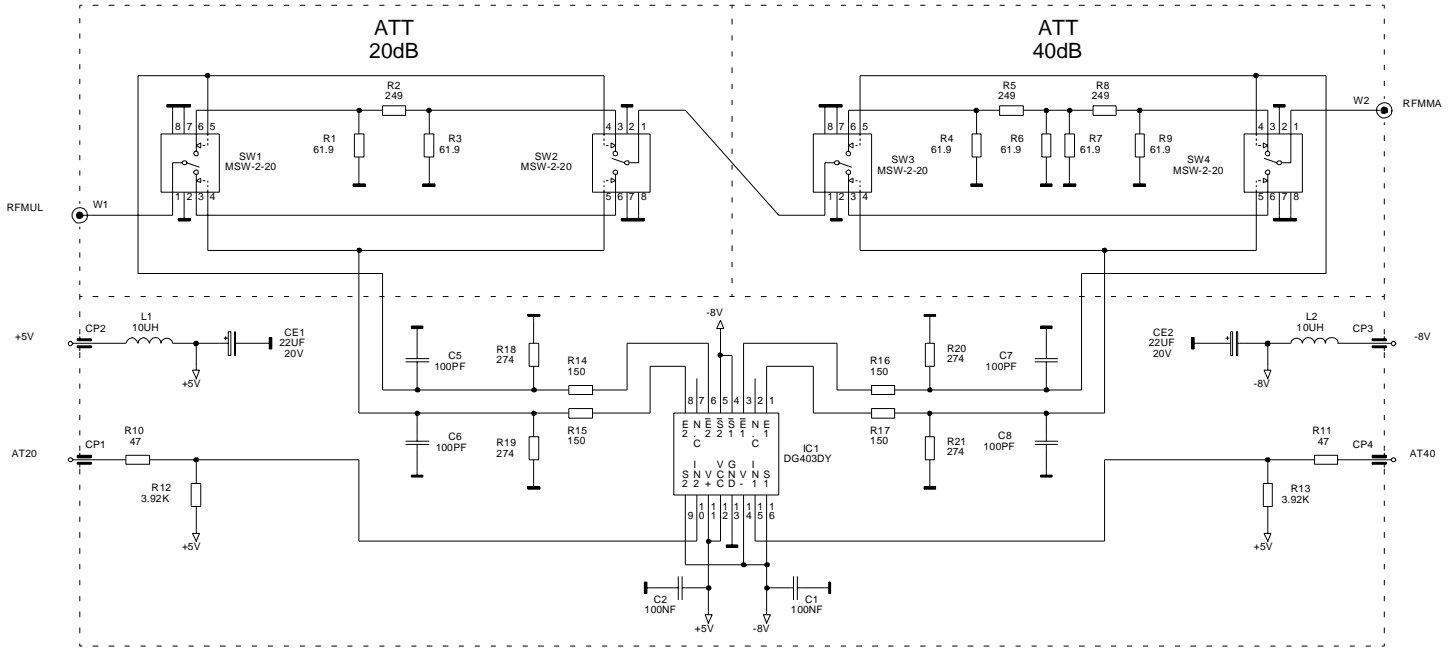
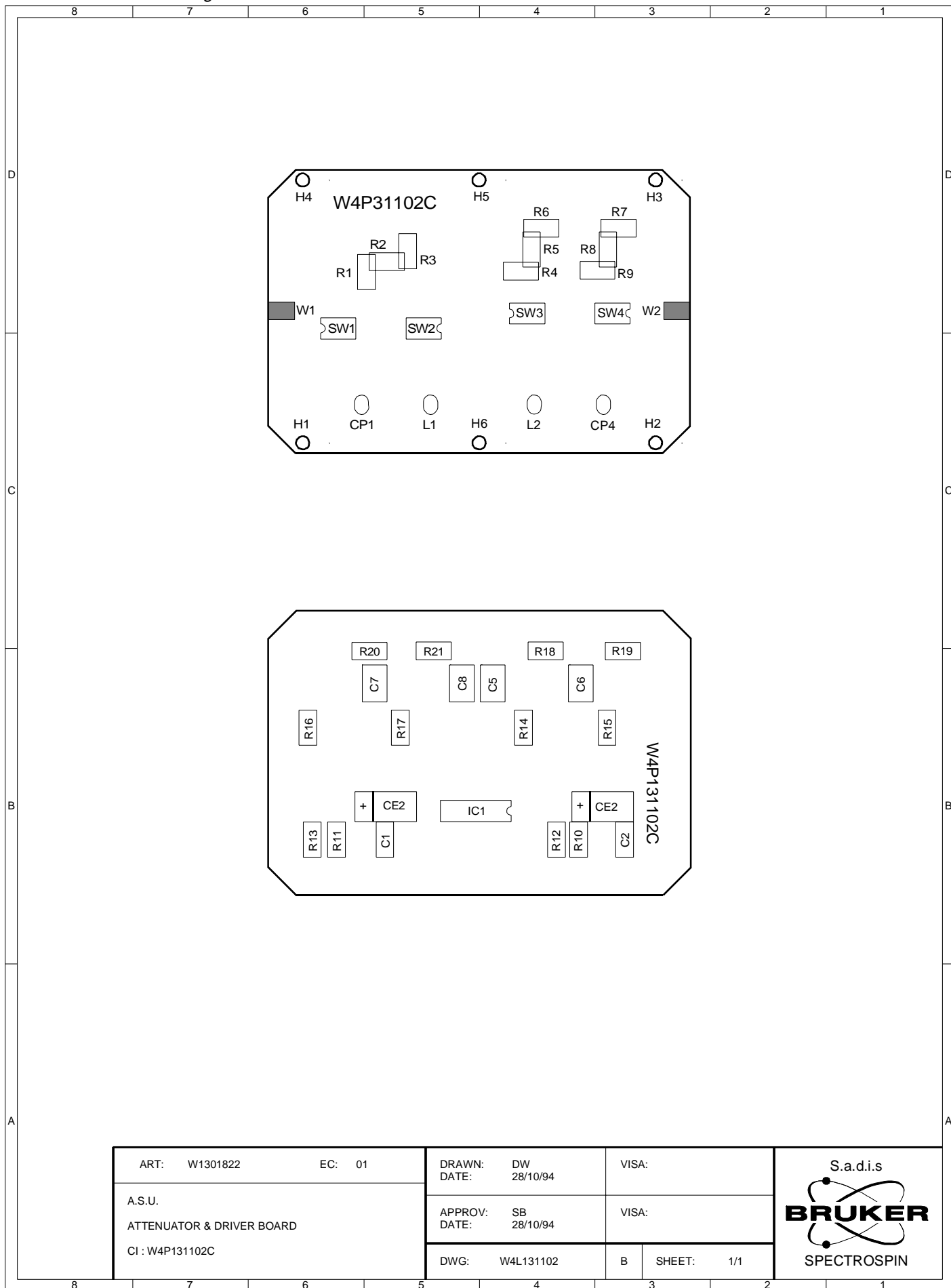

Figure 3.6. Attenuator Schematic

ART: W1301948	EC: 01	DRAWN: DW DATE: 26/09/94	VISA:
AMPLITUDE SETTING UNIT ATTENUATOR & DRIVER BOARD		APPROV: SB DATE: 26/09/94	VISA:
		DWG: W4S132081	SHEET: 1/1



Figure 3.7. Attenuator Location

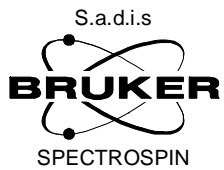

ART: W1301822	EC: 01	DRAWN: DW	VISA:	
A.S.U.		DATE: 28/10/94		
ATTENUATOR & DRIVER BOARD		APPROV: SB	VISA:	
CI : W4P131102C		DATE: 28/10/94		
		DWG: W4L131102	B	SHEET: 1/1

Value Table

+-- Value Tab Head -----+			
	Part:W1301948 Drawing:W4S132081	Copy In Part:	Draw:
	Desc:ASU ATTENUATEUR & PILOTE	ECL:0	Modified:27/10/97 By:MN
+-- Value Tab -----+			
Pos.	Component	Local Description	
C1	8493	COND CMS 1206 100N 50V 20% X7R	
C2	8493	COND CMS 1206 100N 50V 20% X7R	
C5	30412	COND CMS CDR14 100P 500V 20%	
C6	30412	COND CMS CDR14 100P 500V 20%	
C7	30412	COND CMS CDR14 100P 500V 20%	
C8	30412	COND CMS CDR14 100P 500V 20%	
CE1	51557	COND CMS TANTAL 22U 20V 20%	
CE2	51557	COND CMS TANTAL 22U 20V 20%	
CI1	W1356233	CI ASU ATTENUATOR & DRIVER	
CP1	59995	ACCBL PICOT FOURCHE D1.1MM	
CP4	59995	ACCBL PICOT FOURCHE D1.1MM	
IC1	22554	IC 403/SWI DG403DY SO16	
L1	30155	SELF 10UH 0.14A	
L2	30155	SELF 10UH 0.14A	
R1	8853	RES CMS 61.9 1% 0.25W 1206	
R2	56314	RES CMS 249 1% 0.25W 1206	
R3	8853	RES CMS 61.9 1% 0.25W 1206	
R4	8853	RES CMS 61.9 1% 0.25W 1206	
R5	56314	RES CMS 249 1% 0.25W 1206	
R6	8853	RES CMS 61.9 1% 0.25W 1206	
R7	8853	RES CMS 61.9 1% 0.25W 1206	
R8	56314	RES CMS 249 1% 0.25W 1206	
R9	8853	RES CMS 61.9 1% 0.25W 1206	
R10	73283	RES CMS 47.5 1% 0.25W 1206	
R11	73283	RES CMS 47.5 1% 0.25W 1206	
R12	20744	RES CMS 3.92K 1% 0.25W 1206	
R13	20744	RES CMS 3.92K 1% 0.25W 1206	
R14	20726	RES CMS 150 1% 0.25W 1206	
R15	20726	RES CMS 150 1% 0.25W 1206	
R16	20726	RES CMS 150 1% 0.25W 1206	
R17	20726	RES CMS 150 1% 0.25W 1206	
R18	53689	RES CMS 274 1% 0.25W 1206	
R19	53689	RES CMS 274 1% 0.25W 1206	
R20	53689	RES CMS 274 1% 0.25W 1206	
R21	53689	RES CMS 274 1% 0.25W 1206	
SW1	56407	SW ASGA CMS DC-1GHZ	
SW2	56407	SW ASGA CMS DC-1GHZ	
SW3	56407	SW ASGA CMS DC-1GHZ	
SW4	56407	SW ASGA CMS DC-1GHZ	

Specifications

4

Characteristics of Amplitude Setting Unit 1 Channel

4.1

The specifications below fit with the last upgrading of the unit. (February 1997)

RF specifications

4.1.1

Frequency range	5 to 650 MHz
Gain	1 dB \pm 1 dB
Input power	4 dBm \pm 0,5 dB
Output power	5 dBm \pm 1 dB for 4 dBm IN
Input VSWR	1.4
Output VSWR	1.5
Power out 1 dB Compression	6 dBm
Output harmonics H2	- 30 dBm
Output harmonics H3	- 30 dBm

Dynamics

4.1.2

Dynamic range	120 dB
Modulation dynamic	50 dB (40dB @ 600 MHz)
Multiplication dynamic	30 dB (26dB @ 600 MHz)
Attenuators	20 dB + 40 dB

Phase shift

4.1.3

Modulation @ 50 dB Range	5° for 40 dB @ 600 MHz
Multiplication @ 30 dB	15°

Isolation (SPENAB CMD)

4.1.4

Isolation input / output	75 dB
Isolation input / Output + ATT : 60 dB	> 140 dB

Specifications

Output noise level

4.1.5

Unblanked (MOD, MULT = 0V)	< -135 dBm (1 Hz)
Unblanked (MOD, MULT = 2.5V)	< -124 dBm (1 Hz)
Blanked (ATT = 60 dB, SPF = 0V)	Thermal noise

Switching time

4.1.6

Rise Time	20 ns
DC Ringing	150 mV
Fall Time	10 ns
DC Ringing	10 mV
Propagation Time	40 ns

DC requirements

4.1.7

Supply +15V	675 mA
Supply -15V	425 mA
Supply +5V	140 mA

Operating temperature

4.1.8

Temperature range	+20°C @ +40°C
-------------------	---------------

Figures

1 ASU 1 Channel	7
Figure 1.1. Amplitude Setting Unit 1 Channel Location	8
Figure 1.2. Amplitude Setting Unit 1 Channel Block Diagram	9
Figure 1.3. Amplitude Setting Unit 1 Channel Wiring Diagram	10
2 Interface	11
Figure 2.1. Interface Schematic	12
Figure 2.2. Interface Location	13
Figure 2.3. PAL ASU03/01 Logical Program	14
3 MMA Unit	19
Figure 3.1. Modulation, Multiplication & Attenuator Block Diagram	20
Figure 3.2. Modulation Schematic	21
Figure 3.3. Modulation Location	22
Figure 3.4. Multiplication Schematic	25
Figure 3.5. Multiplication Location	26
Figure 3.6. Attenuator Schematic	29
Figure 3.7. Attenuator Location	30
4 Specifications	33

Tables

1	ASU 1 Channel	7
2	Interface	11
Table 2.1.	Front Panel Connector J1	17
Table 2.2.	Rear Panel Connector J2	18
3	MMA Unit	19
4	Specifications	33

