

Installation Manual for Bruker NMR Systems

Anti Vibration Feet for Bruker Cryostats

D205 / D207 / D232 / D241 / D245

Version 002



The information in this manual may be altered without notice.

BRUKER BIOSPIN AG accepts no responsibility for actions taken as a result of use of this manual. BRUKER BIOSPIN AG accepts no liability for any mistakes contained in the manual, leading to coincidental damage, whether during installation or operation of the instrument. Unauthorized reproduction of manual contents, without written permission from the publishers, or translation into another language, either in full or in part, is forbidden.

This manual was written by

Daniel B. Baumann

daniel.baumann@bruker-biospin.ch

© Date: 17.03.2003: BRUKER BIOSPIN AG

CH-8117 Faellanden, Switzerland

P/N: Z30995
DWG-Nr: 694002

BRUKER BIOSPIN AG

Magnet Division

NMR Magnet Systems

phone: ++41 1 825 91 11

fax: ++41 1 825 96 96

e-mail: magnetics@bruker-biospin.ch

service_magnetics@bruker-biospin.ch

sales_magnetics@bruker-biospin.ch

Installation Manual

Anti Vibration Feet Z53421

for Bruker Cryostats

D205/D207/D232/D241/D245

Table of Contents

1 Introduction	7
2 Safety precautions	8
3 Operating Principles	9
4 Installation	10
5 Check Function	14
6 Upgrade of older Pneumatic Vibration Damping Systems	15
7 Maintenance	16
8 Troubleshooting	16

1 Introduction

Anti-Vibration Feet Z53421



The pneumatic vibration damping system is designed for cost effective passive isolation of NMR magnet systems from floor vibration.

This cost effective system can achieve damping factors of 10 for vibrations at 20 Hz or above. For lower frequencies, very little damping will be achieved.

The updated version has a Niveau regulator. With this new feature the magnet system will remain upright, even when a sample changer's arm is moving.

Some old damper versions can be upgraded.

2 Safety precautions



Use only non magnetic tools for the installation of the dampers.

The maximum air pressure is 10 bar.

The maximum lifting power for each bumper is 500 kg at 7 bar

Do not lift the magnet stand by more than 15 mm.

Do not use the cover of the damping unit as steps, when climbing onto the cryostat.

Do not shake the cryostat if the pneumatic dampers are in operation.

The pneumatic dampers must be released for all operations above or below the cryostat, especially the refilling of helium.

3 Operating Principles



Vibration damping is achieved through the use of three commercial rubber bumpers.

These dampers are now equipped with pressure regulator valves. They change the pressure inside the rubber bumpers in regards to the position of the leveling screw. The main advantage of this regulator is a stable vertical position of the magnet, even when a sample changer is moving its arm back and forth from the magnet.

Frequencies are damped above 8 Hz. The resonance frequency is about 5 Hz, depending on the adjusted pressure at the pneumatic control box. The diagram below shows the typical transmissibility function with the peak of the resonance frequency. Be aware that frequencies in this range are transmitted up to a factor of 10 in amplitude.

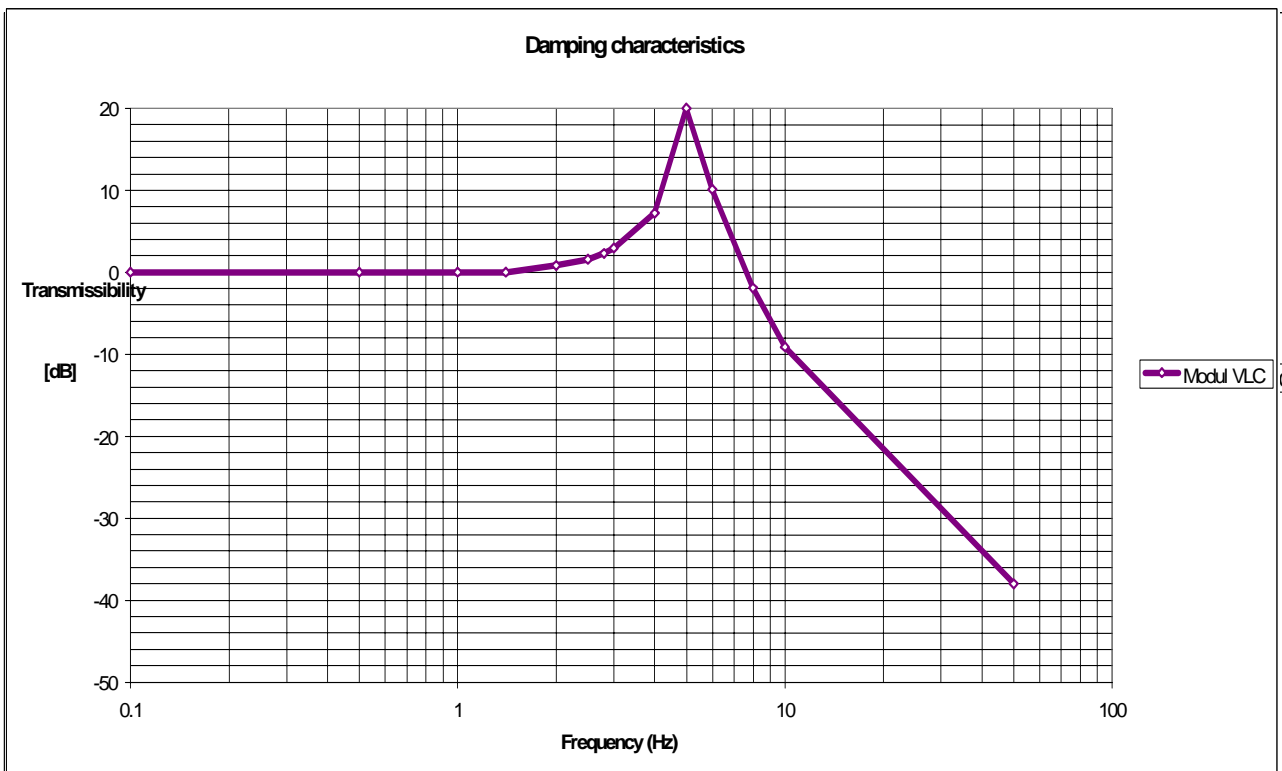

4 Installation



For the following installation you need:

- Allen keys (2.5mm, 4mm and 6mm)
- Two wrenches 8mm
- A bubble level (spirit level).

4.1 Unpacking



The Anti-Vibration Feet P/N Z53421 includes:

- 3 Dampers
- 1 Pneumatic Control Box
- 8 mm gas hose for supply system
- 6 mm gas hose for the pneumatic dampers
- Set of 6 screws M8x25
- Set of clamps to fix hoses
- Manual

4.2 Check the cover position

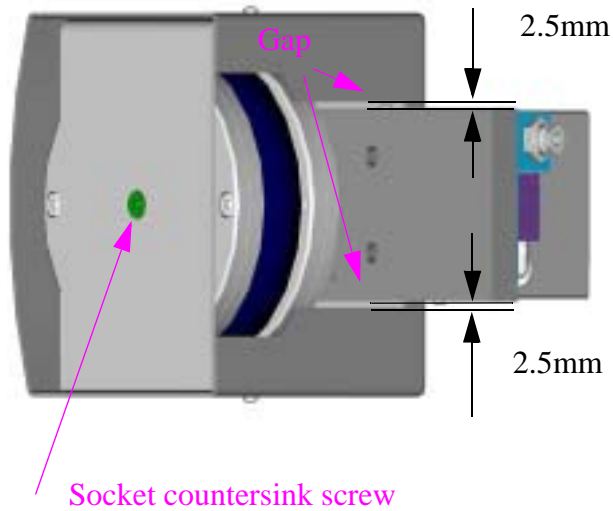

Before you unscrew the covers you have to check the correct position of the rubber bumper. To do this you have to turn it upside down and check the distance (gap) between the cover and the fixture part to the magnet stand. The gap to the cover should be equal (approx. 2.5mm) on both sides. You can adjust the position using the countersink screw.

4.3 Mount the Vibration Dampers to the magnet stand

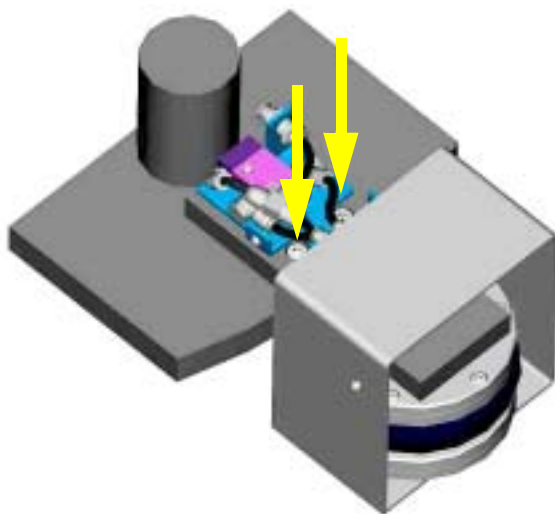

-Screw the air mount to the magnet base plate. Use a 6mm Allen key for the M8x25 screws.

-Place the control box either on the magnet stand or next to it.

-Adhere the control box to the stand bottom plate using adhesive tape or the small self-sticking knobs.

-Cut the 6mm air hose to an optimal length and connect it to the control box.

4.4 Align magnet perpendicular

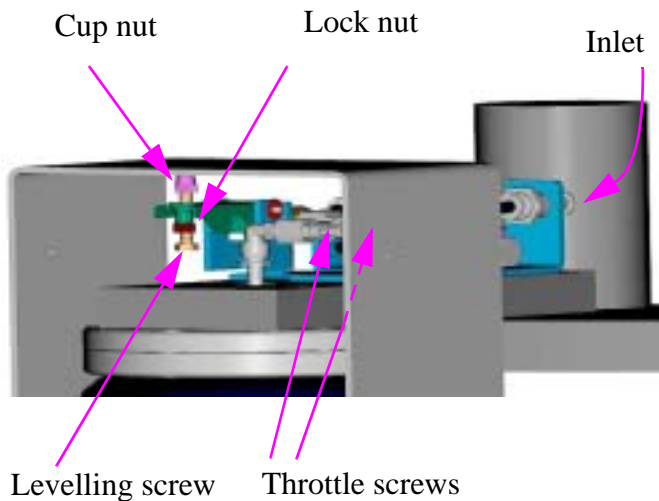

Switch the gas supply on and adjust the pressure reducing valve to approx. 5 bar. The gas supply must always be 0.5 -1 bar higher than the regulated gas behind the pressure reducer valve.

When the input pressure changes too much, a buffer gas tank can reduce the influence of gas pressure changes on the damping system.

The magnet stand should remain approx. 10 mm higher.

Align the magnet perpendicular by using the leveling screw. Open first the lock nut if necessary.

Turning leveling screw upwards (counter clockwise) will lower the magnet.

Turning leveling screw down (clockwise) will raise the magnet.

Important: Do not loosen the cup nuts or misplace the throttle screws.

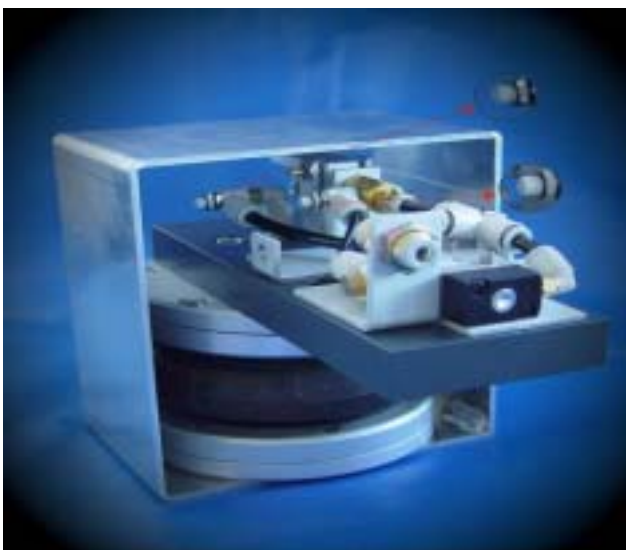

The throttle-valves are preset, opened by 1.5 turns. Do not alter this setting!

4.5 Install the Covers

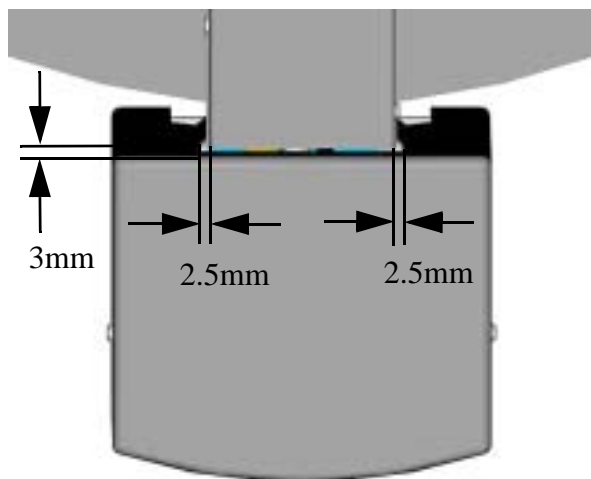

Install first the large cover, then the small over the regulator valve. Use the 4 pan head screws M4 x 10 for securing.

Check the gaps. Incorrect gaps will allow floor vibrations to be transferred to the magnet.

4.6 Pneumatic Control Box



The pneumatic control box has one gas supply inlet and a total of 6 outlets for the pneumatic bumpers.

A one-way valve is connected (see diagram) immediately after the input.

It is possible to connect a buffer tank to reduce the influence of gas pressure changes.

The main switch includes an outlet with a noise absorber for the lowering of the magnet system (off-position).

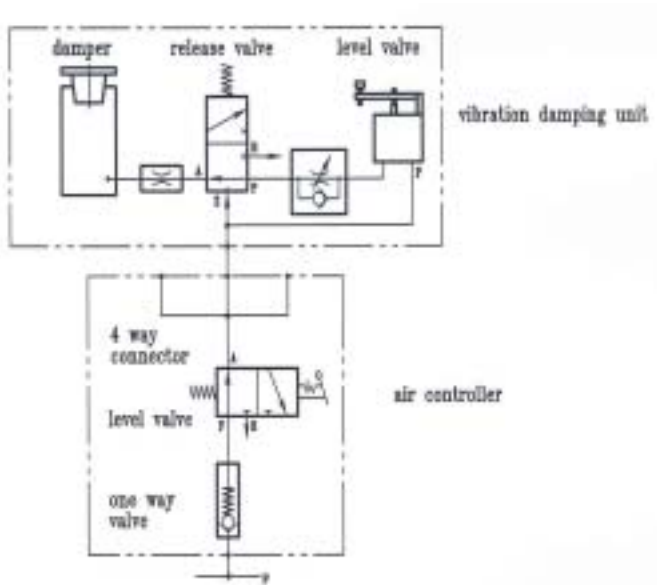

The accompanying diagram shows the pneumatic control box (air controller) and the pneumatic bumpers (vibration damping unit).

The inlet from the main gas supply is shown in the bottom of the diagram (P).

5 Check Function

The following conditions indicate that the system is functioning correctly:

The magnet system can be raised and lowered smoothly.

The system remains in the vertical position after several cycles.

No noise is audible indicating a leaking Legris connector.

6 Upgrade of older Pneumatic Vibration Damping Systems

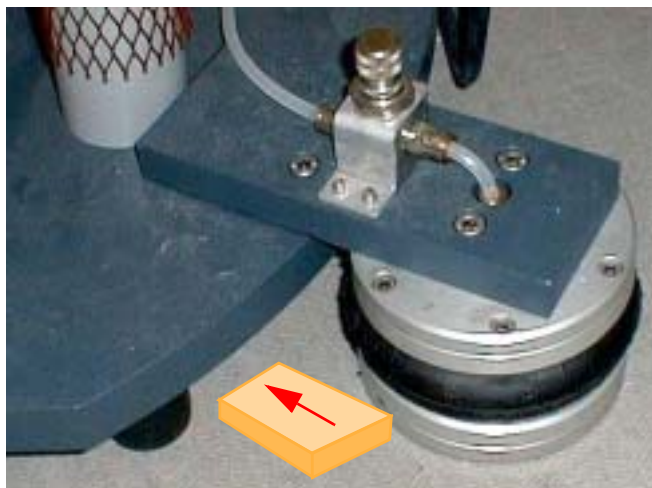

Only pneumatic vibration damping systems with a separate pressure regulator valve can be upgraded to the newest self-leveling system (see photograph).

Installation:

- Raise the magnet system. Insert 3 pads (thickness approx. 5mm) below the rubber legs.
- Lower the magnet system onto these pads.
- Remove the old pressure regulator valves by unscrewing the socket head cap screws.
- Pull out the gas hose.
- Mount the regulation device.
- Securing using same M4x10 screws. Connect the gas hoses.
- The throttle valves are preset, opened by 1.5 turns, do not alter.

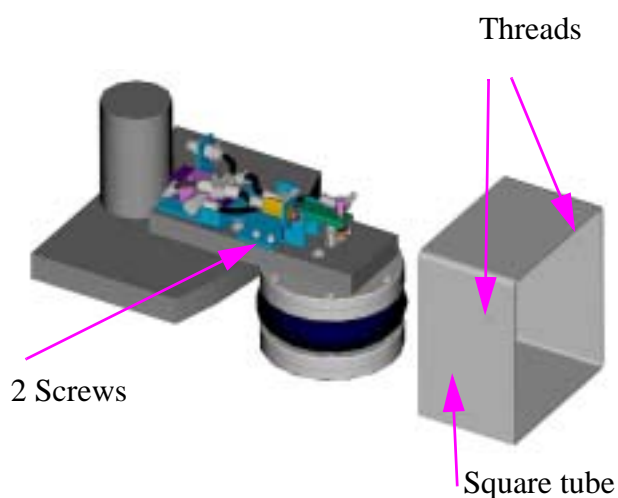

- Push the square tube under the bumper (airspring). Watch the thread positions. Align concentrically and at a right angle. (There are no screw threads at the bottom plate of the bumper, thus you can't fix it there).

- For additional installation instructions follow the standard procedure starting chapter 4.4, "Align magnet perpendicular," on page 12

7 Maintenance

This pneumatic vibration damping system requires no maintenance. The unit is designed to be raised and lowered at least once a week for a period of 12 years.

8 Troubleshooting

-Magnet system will not raise up:

Check the incoming gas supply pressure (approx. 5 bar). Remove the cover and check the level valve.

Check the throttle valves (should be opened by 1.5 turns)

-Magnet system is shaking:

Check the incoming gas pressure. It must be always 0.5-1 bar higher than the pressure at the manometer.

Check the 2 throttle valves at each damper. They should be opened by 1.5 turns.

Check for a gas leak. A helium flow meter can be very helpful in finding small leaks.

-Vibration visible:

Check to see if the covers of the pneumatic bumpers are touching. Remove them and repeat the measurements.

These pneumatic bumpers have a resonance frequency of 5Hz. This resonance frequency depends on the gas pressure and can be adjusted by approx. +/- 0.5 Hz.

At this resonance frequency they amplify incoming vibrations by 20 dB (which is a factor 10 in amplitude).

Measure the amplitude of vibration, when the magnet system is declined. Repeat the same measurements when the magnet is raised. Check with the damping characteristics. Be aware that these bumpers can damp frequencies only above 8 Hz. Above 20 Hz amplitude of vibration should be reduced by a factor of 10.

Index

A

- adhesive tape 11
- air mount 11
- airspring 15
- Allen keys 10
- Anti-Vibration Feet Z53421 7, 10

B

- bubble level 10
- buffer gas tank 12
- buffer tank 13

C

- Check the cover position 11
- clamps 10
- climbing 8
- countersunk screw 11
- cover 13

F

- floor vibration 7, 13

G

- gap 11, 13
- gas hose 10
- gas supply pressure 16

H

- helium flow meter 16

L

- Legris connector 14

M

- magnet base plate 11
- magnet stand bottom plate 11
- main switch 13
- maximum air pressure 8
- maximum lifting power 8

N

- non magnetic tools 8

O

- one way valve 13
- Operating Principles 9

P

pan head screws 13
Pneumatic Control Box 10, 13
pneumatic vibration damping system 7
pressure regulator valves 9

R

refilling of helium 8
regulation device 15
resonance frequency 16
rubber bumper 11

S

Safety precautions 8
sample changer 9
shake the cryostat 8
square tube 15

T

throttle-valves 12

U

Unpacking 10
Upgrade 15

W

wrenches 10